



Install your **future**



SYSTEM **KAN-therm**

Catalogue

SPECIALIZED INSTALLATIONS



Complete multipurpose installation system consisting of state-of-the-art, mutually complementary technical solutions for pipe water distribution installations, heating installations, as well as technological and fire extinguishing installations.

Install your **future**

COLOUR SYSTEM



SYSTEM NAME

ultra**LINE**

Push

ultra**PRESS**

PP

Steel

Inox

DIAMETER RANGE [mm]

14-32

12-32

16-63

16-110

12-108

12-168,3

INSTALLATIONS TYPE





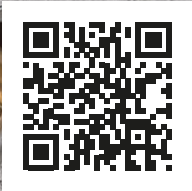

TAP WATER	<input checked="" type="checkbox"/>	<input checked="" type="checkbox"/>	<input checked="" type="checkbox"/>	<input checked="" type="checkbox"/>	<input type="checkbox"/>	<input checked="" type="checkbox"/>
HEATING	<input checked="" type="checkbox"/>	<input checked="" type="checkbox"/>	<input checked="" type="checkbox"/>	<input checked="" type="checkbox"/>	<input checked="" type="checkbox"/>	<input checked="" type="checkbox"/>
TECHNOLOGICAL HEAT	<input type="checkbox"/>	<input type="checkbox"/>	<input type="checkbox"/>	<input type="checkbox"/>	<input type="checkbox"/>	<input type="checkbox"/>
WATER STEAM	<input type="checkbox"/>	<input type="checkbox"/>	<input type="checkbox"/>	<input type="checkbox"/>	<input type="checkbox"/>	<input type="checkbox"/>
SOLAR	<input type="checkbox"/>	<input type="checkbox"/>	<input type="checkbox"/>	<input type="checkbox"/>	<input type="checkbox"/>	<input type="checkbox"/>
COOLING	<input type="checkbox"/>	<input type="checkbox"/>	<input type="checkbox"/>	<input type="checkbox"/>	<input type="checkbox"/>	<input checked="" type="checkbox"/>
COMPRESSED AIR	<input type="checkbox"/>	<input type="checkbox"/>	<input type="checkbox"/>	<input type="checkbox"/>	<input type="checkbox"/>	<input type="checkbox"/>
TECHNICAL GASES	<input type="checkbox"/>	<input type="checkbox"/>	<input type="checkbox"/>	<input type="checkbox"/>	<input type="checkbox"/>	<input type="checkbox"/>
FLAMMABLE GAS	<input type="checkbox"/>	<input type="checkbox"/>	<input type="checkbox"/>	<input type="checkbox"/>	<input type="checkbox"/>	<input type="checkbox"/>
TECHNICAL OILS	<input type="checkbox"/>	<input type="checkbox"/>	<input type="checkbox"/>	<input type="checkbox"/>	<input type="checkbox"/>	<input type="checkbox"/>
INDUSTRIAL	<input type="checkbox"/>	<input type="checkbox"/>	<input type="checkbox"/>	<input type="checkbox"/>	<input type="checkbox"/>	<input type="checkbox"/>
BALNEOLOGICAL	<input type="checkbox"/>	<input type="checkbox"/>	<input type="checkbox"/>	<input type="checkbox"/>	<input type="checkbox"/>	<input type="checkbox"/>
SPRINKLER FIRE-FIGHTING	<input type="checkbox"/>	<input type="checkbox"/>	<input type="checkbox"/>	<input type="checkbox"/>	<input type="checkbox"/>	<input type="checkbox"/>
HYDRANT FIRE-FIGHTING	<input type="checkbox"/>	<input type="checkbox"/>	<input type="checkbox"/>	<input type="checkbox"/>	<input type="checkbox"/>	<input type="checkbox"/>
UNDERFLOOR HEATING AND COOLING	<input checked="" type="checkbox"/>	<input checked="" type="checkbox"/>	<input checked="" type="checkbox"/>	<input type="checkbox"/>	<input type="checkbox"/>	<input type="checkbox"/>
WALL HEATING AND COOLING	<input checked="" type="checkbox"/>	<input checked="" type="checkbox"/>	<input checked="" type="checkbox"/>	<input type="checkbox"/>	<input type="checkbox"/>	<input type="checkbox"/>
CEILING HEATING AND COOLING	<input checked="" type="checkbox"/>	<input checked="" type="checkbox"/>	<input checked="" type="checkbox"/>	<input type="checkbox"/>	<input type="checkbox"/>	<input type="checkbox"/>
EXTERNAL SURFACES HEATING AND COOLING	<input checked="" type="checkbox"/>	<input checked="" type="checkbox"/>	<input checked="" type="checkbox"/>	<input type="checkbox"/>	<input type="checkbox"/>	<input type="checkbox"/>

In untypical cases, it is necessary to check the conditions of using KAN-therm parts with technical and information materials or opinions of the KAN Technical Department. Use the form – Inquiry about the possibility to use KAN-therm elements – to send basic parameters of an installation operation. Based on the data sent, the Technical Department will assess the fitness of the system to the particular installation. The form can be found on the website. Scan the QR code to fill in the electronic form quickly.



SYSTEM **KAN-therm**



 Copper	 Surface heating	 Cabinets, manifolds	 Groove	 Copper Gas	 Sprinkler Steel	 Sprinkler Inox
12-108	12-25	-	DN25-DN300	15-54	22-108	22-108
●		●				○
●	●	●				
		○				
●	○	○				
○			○	○	○	○
○				○	○	○
				●		
○			○			
					●	●
					●	●
	●	●				
	●	●				
	●	●				
	●	●				

● standard scope of application
 ○ possible use – the conditions to be confirmed with the KAN Technical Department

Table of contents

SYSTEM KAN-therm Sprinkler	5
SYSTEM KAN-therm Steel Sprinkler	27
carbon steel press pipes and fittings for sprinkler and hydrant systems	
SYSTEM KAN-therm Inox Sprinkler	59
stainless steel press pipes and fittings for sprinkler and hydrant systems	
SYSTEM KAN-therm Copper Gas	91
copper press fittings for gas installations	
SYSTEM KAN-therm Groove	125
for industrial and technological installations	

This commercial information is effective as of 01.09.2022 r. Availability of goods according to individual arrangements.
The photographs presenting the offered goods are for reference only. Actual colour and design details of the elements may differ from those presented in the photographs.
When the new catalogue is released, the information contained in the earlier version of the catalogue will be updated.
KAN Sp. z o.o. reserves the right to supplement, change or replace commercial and technical information at any time.
© KAN Sp. z o.o. copyrights All rights reserved. Text, images, graphics and their layout in KAN Sp. z o.o. publications are covered by copyrights.

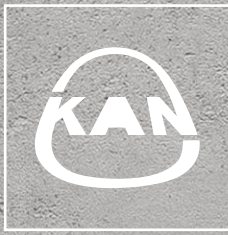

Install your **future**

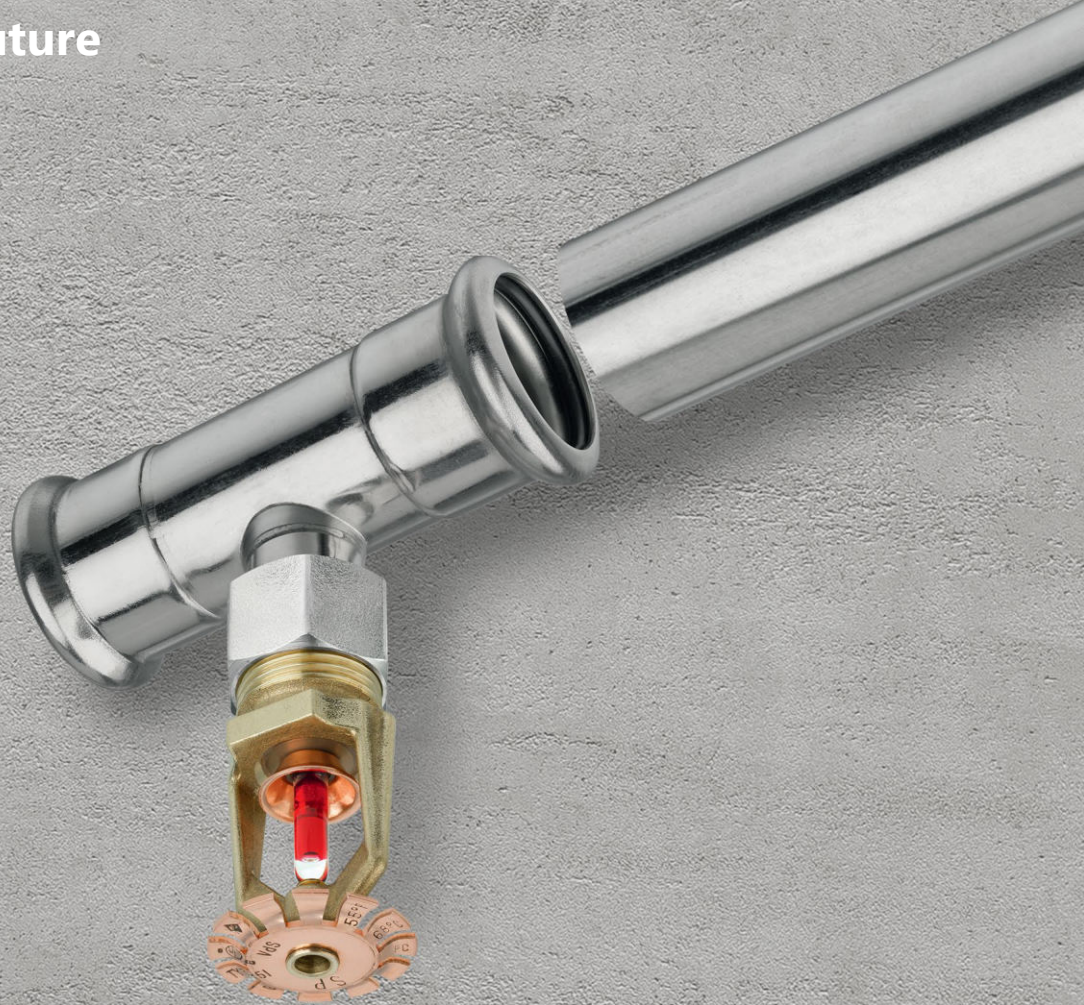

SYSTEM **KAN-therm**

Sprinkler

Fire safety
for years to come

EN 22/09

Ø 22-108 mm

Table of contents

System **KAN-therm** Sprinkler

1	Introduction	8
1.1	KAN-therm Sprinkler features	8
2	KAN-therm Sprinkler system application	9
3	“Press” assembly technique	11
3.1	LBP O-Ring seal	11
4	KAN-therm System elastic hoses	12
5	KAN-therm Sprinkler system tools	14
6	Assembly guidelines	19
6.1	Threaded connections	22
7	General information regarding system installation	23
7.1	Fitting pipelines	23
7.2	Pipeline flushing	24
8	Tightness test	24
9	Transport and storage	24
10	General hydraulic dimensioning guidelines for KAN-therm Sprinkler systems	25

System **KAN-therm** Steel Sprinkler

1	Application and operating conditions	27
2	KAN-therm Steel Sprinkler system - carbon steel pipes	29
3	KAN-therm Steel Sprinkler system - pressed carbon steel couplings	30

System **KAN-therm** Inox Sprinkler

1	Application and operational conditions	59
2	KAN-therm Inox Sprinkler system - stainless steel pipes	61
3	KAN-therm Inox Sprinkler system - pressed stainless steel couplings	62

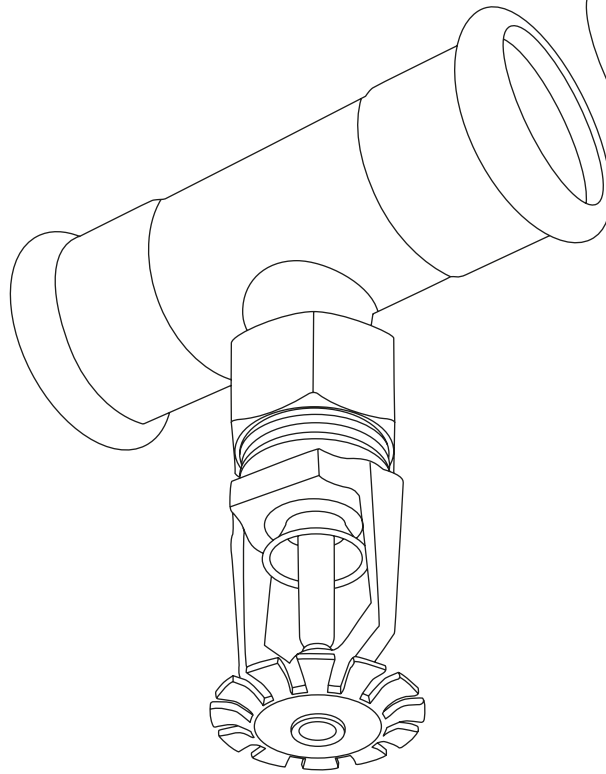

SYSTEM **KAN-therm**

Sprinkler

KAN-therm Sprinkler is a complete fire extinguishing installation system consisting of pipes and fittings made of zinc-plated carbon steel (Steel Sprinkler) or stainless steel (Inox Sprinkler) in 22–108 mm (DN20 – DN100) diameter range.

Particular system elements are joined using the state of the art, professional and, most of all, safe “Press” technique based on pressing fittings on the pipe using dedicated tools.

The KAN-therm Sprinkler system is designed for constructing indoor-use, fire fighting hydrant* and sprinkler systems. Both material versions are verified and certified according to VdS guidelines for application in stationary sprinkler systems after emergency valves, within rooms characterized by low or medium fire hazard (LH, OH1, OH2, OH3, and to OH4 in respect to exhibition halls, cinemas, theatres and concert halls).

KAN-therm Sprinkler systems are ideal for constructing new and replacing old, traditional fire extinguishing sprinkler installations.

* according to national regulations, hydrant systems are certified by Polish CNBOP.

1 Introduction

As fire safety in newly created and renovated objects, as well as the pursue to minimize installation construction time become a big concern, innovative systems like KAN-therm Sprinkler appear as an obvious choice.

1.1 KAN-therm Sprinkler features

There are many systems on the constructions market using conventional solutions, such as threading, welding and soldering. The advantages brought by applying „Press“ coupling technique, as compared to the above mentioned, have been already appreciated long time ago.

It is the aesthetics of systems constructed using KAN-therm Sprinkler that is frequently the main reason for which architects and designers choose our products for constructing fire extinguishing mechanisms.



All elements of the system are manufactured in a modern plant, which allows us to guarantee unshaken quality and availability of our products. Use of the advanced technology of laser welding in the production process assures an absolute control of all elements. Fully automated tightness testing is an integral part of the laser welding process. All straight couplings with screwed ending are produced from one element, thanks to which the couplings' dimensions are limited to the minimum, just like the risk of occurrence of leaks. Thanks to an extraordinarily smooth surface of pipes and fittings, the obtained flow characteristics allow for a significantly increased efficiency, as compared to conventional solutions. The high quality of KAN-therm Sprinkler system has been confirmed by national and international certifying bodies.

Reliability

In KAN-therm Sprinkler systems, the quality of joint mainly depends on the used tool. This minimizes risk of human-caused assembly faults.

To limit the risk of occurrence of human-caused assembly faults, all KAN-therm Sprinkler System fittings feature LBP (Leak Before Press) function, detecting non-pressed joints. For fittings of dimensions up to DN50, inclusive, the LBP functionality is assured by specific structure of the sealing O-Ring; for elements of dimensions above DN50, the fitting's stub pipe has been ovalized. The LBP function allows for occurrence of a distinct leakage from the pipe-fitting joint, if the joint has not been pressed. This makes it easy to quickly state which connections have not been pressed during installation, and perform the necessary repairs. After pressing the fitting on the pipe, tightness is guaranteed.

KAN-therm Sprinkler system advantages:

- quick and secure installation and assembly, without the necessity of welding or screwing pipes (risk of working with open fire eliminated),
- wide range of pipe and fitting diameters - from 22 mm to 108 mm,
- high aesthetics of the performed installations, without the necessity of painting,
- low specific weight of pipes and fittings,
- optimized fitting dimensions assure easier construction of the installation,

The above features cause KAN-therm Sprinkler system to be easy and comfortable in assembly, not requiring specific skills.

KAN-therm Sprinkler System assembly takes place without use of open fire (as opposed to welding or soldering), or applying other heavy and potentially dangerous tools.

Thanks to the minimal requirements, KAN-therm Sprinkler system is a perfect solution for modernizations or renovations. Additionally, the small weight of KAN-therm Sprinkler pipes and fittings and their precision of making contribute to improvement of conditions and increase of work comfort.

Short KAN-therm Sprinkler system assembly time, as compared to conventional assembly systems, is a very important factor, decreasing costs related with investment execution.

We are convinced that the presented advantages encourage you to try KAN-therm Sprinkler system when designing and constructing sprinkler systems.

2 KAN-therm Sprinkler system application

KAN-therm Sprinkler system may be used in the construction of stationary fire protection installations, both hydrants and sprinklers.

Indoor hydrant installations

KAN-therm Sprinkler System in indoor hydrant systems is certified by National Technical Assessment issued by Polish CNBOP.

KAN-therm Steel Sprinkler is suitable for performing only indoor, constantly filled with water, non-flow (until fire extinguishing) hydrant installations which are totally separated or single-side connected to potable water systems.

KAN-therm Inox Sprinkler is suitable for performing indoor dry and constantly filled with water hydrant installations. It may be combined with or be a part of potable water systems.

Sprinkler installations

Stationary sprinkler installations are built-in fire extinguishing and prevention systems that independently detect and report fire, and automatically initiate the extinguishing process.

KAN-therm Sprinkler system assembly in sprinkler systems should be performed according to the applicable guidelines (e.g. VdS-CEA 4001 or PN-EN 12845).

Depending on the applied material (stainless steel or galvanized steel), the system may be used with water (wet) or dry stationary sprinkler systems.

KAN-therm Steel Sprinkler System is designed for use with only wet sprinkler systems, whereas KAN-therm Inox Sprinkler System may be applied with wet, as well as dry stationary sprinkler systems.

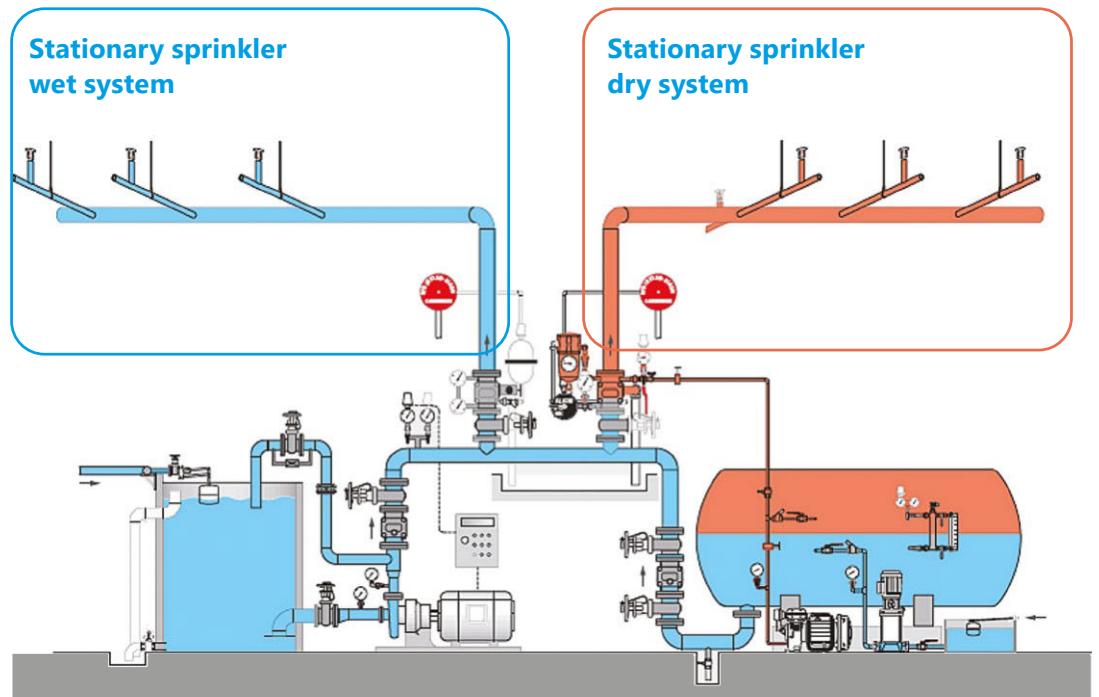

KAN-therm Steel Sprinkler and KAN-therm Inox Sprinkler systems have been tested and certified according to the VdS guidelines for application in stationary sprinkler installations equipped with emergency valve.

The following guidelines refer to all products comprising KAN-therm Sprinkler system, operating at working pressure stated in the below table:

TAB. 1 OPERATING PRESSURE IN KAN-THERM SPRINKLER SYSTEM

DN	Internal Ø [mm]	Sprinkler system	
		Steel Sprinkler - wet [bar]	Inox Sprinkler - wet and dry [bar]
20	22	16	16
25	28	16	16
32	35	16	16
40	42	16	16
50	54	16	16
65	76,1	12,5	16
80	88,9	10	12,5
100	108	10	10

Application is limited exclusively to KAN-therm Sprinkler system original elements. Connecting elements other than the original (not included in the KAN-therm Sprinkler system offer) is permissible only on the condition of using detachable metal connections (threaded, grooved or flanged).

Assembly and installation of KAN-therm Sprinkler System may be performed only by qualified technical personnel, having formal qualifications for performing sprinkler system-related works. Requirements regarding assembly of stationary sprinkler installations are included in VdS-CEA 4001 or PN-EN 12845 guidelines. The company performing installation must assure conformity with the above guidelines.

3 “Press” assembly technique

The „Press” coupling technique consists of pressing fittings on the pipe, using specialist power tools.

Tightness of the connections is assured by special O-Ring seals made of EPDM rubber resistant to high temperatures, and „M” type clamping system (O-Ring clamped in three spots). This guarantees long and reliable operation.

1. “M” type clamp system.
2. Joint before pressing.
3. Joint after pressing.

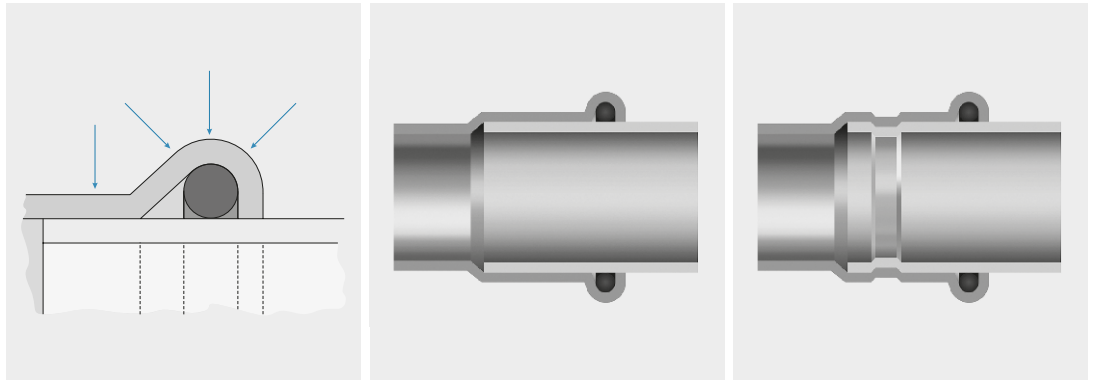

3.1 LBP O-Ring seal

KAN-therm Sprinkler system pressed fittings are equipped with EPDM O-Rings of the following operating parameters:

Material	EPDM LBP (DN20 – DN50)	EPDM (DN65 – DN100)
Colour	black	black
Layer	without silicone, Teflon-based	without silicone, Teflon-based
Operating temperature	-35 °C to +135 °C	-35 °C to +135 °C
Max. temperature (short term)	150 °C	150 °C
Max. operating pressure	16 bar	up to 16 bar (depending on diameter - check application conditions for a given KAN-therm Sprinkler system)
Application range	Wet and dry sprinkler systems	Wet and dry sprinkler systems



Thanks to special slots of the LBP O-Ring body, optimum control of the system during pressure test is assured. The nonpressed joints are easy to locate, as they are not water tight. When pressing, the O-Ring changes its shape, adhering entirely to pipe and fitting surface, assuring reliable and tight joint.

KAN-therm Sprinkler system also offers internal threaded elements that are used for connecting threaded elements from outside of the system (not comprising KAN-therm Sprinkler system), such as sprinklers, valves or other fixtures. Internal and external threads are manufactured in compliance with DIN 2999/ISO 7/1 (taper thread). It is recommended to perform the threaded connection before pressing the fitting, not to stress the pressed joint. To tighten the joint, do not apply Teflon tapes or any other compounds containing chlorides.



4 KAN-therm System elastic hoses

KAN-therm Sprinkler system elastic hoses are covered by approval issued by VdS for stationary sprinkler systems. We offer two versions of hoses, equipped with straight or 90 degree-angled endings. The following dimensions are available:

DN20 and DN25 of 800, 1000, 1500 mm lengths. Elastic hoses designed for fitting in:

- ceiling systems with I-beams, covered with mineral cotton panels and metal cassettes (with fixation to main and auxiliary beams),
- ceiling systems with fixation profiles,
- ceiling systems of gypsum-cardboard panels,
- suspended standard sprinkler systems,
- enclosed sprinklers or sprinklers concealed in cavities.

Assembly of sprinkler lines using stiff pipe conduits in suspended ceilings may be very expensive and time consuming. Use of elastic hoses in sprinkler systems allows easy and quick connection of sprinklers in any place in the area within the hose's length. Elastic hoses assure easy assembly of sprinklers in suspended ceilings, which saves time and costs.

The system comes with assembly holders, which allow safe and reliable fixture of the sprinkler hose to the suspended ceiling.

The elastic hose also feature pipe adapters, 100% compatible with KAN-therm Sprinkler. The pipe adapter assures easy connection of the elastic hose to installation performed in KAN-therm Sprinkler system, using Press fittings. In installations using twisted joints, in order to connect the elastic hose with pipe adapter, KAN-therm Sprinkler fitting must be used that has a threaded ending (external/internal) on its one side, and a pressed ending on the other side. After screwing in the fitting, you only need to plug the hose to the pipe adapter and press the joint.

Features

- easy and quick assembly using standard KAN-therm Sprinkler tools,
- hose made of stainless steel,
- allow for easy assembly in the vicinity of other installation and buildings' structural elements,
- no need for rotating the entire hose during assembly thanks to using straight pipe ending,
- freedom of choice at selecting the system fixing the sprinklers along the ceiling plate,
- no need for bending or lifting ceiling elements thanks to elastic structure of fixture between sprinkler hose and ceiling,
- no need for disassembling and reassembling sprinkler systems during renovations or ceiling replacements. Hoses and holders (together with the installed sprinklers) may be disassembled and reassembled in a new place, without the need of emptying the entire installation (only within the hose length),
- easy vertical setting of the sprinkler thanks to a scale on the sprinkler's sleeve.



ELASTIC HOSE TECHNICAL SPECIFICATION

Sprinkler hose	Type RS 339L92, DN20/DN25, elastic braided structure, performed entirely of stainless steel, welded joints.
Sprinkler joint (straight)	Stainless steel, pipe thread complying with DIN EN 10226 (ISO 7/1), Rp $\frac{1}{2}$ " (SW 27). Scale for easy vertical set-up. Application for installation in limited spaces. Installation height only 170 mm above the lower edge of a suspended ceiling.
Sprinkler joint (angular, 90°)	Stainless steel, pipe thread complying with DIN EN 10226 (ISO 7/1), Rp $\frac{1}{2}$ " (SW 27). Scale for easy vertical set-up. Application for installation in limited spaces. Installation height only 170 mm above the lower edge of a suspended ceiling.
Connection adapter	Stainless steel, straight ending, 22 or 28 mm diameter for connecting with KAN-therm Sprinkler system connectors.
Nominal length	800, 1000, 1500 mm
Max. operating pressure	16 bar, 100% tightness control
Minimum bend radius	70 mm for Ø22 hoses; 85 mm for Ø28 hoses

5 KAN-therm Sprinkler system tools

Pressing of the KAN-therm Sprinkler fittings should be performed using pressing units and press jaws ("M" and "HP" profile depending on the diameter), delivered by KAN-therm Sprinkler system.

Name	Permissible pressed diameters range	Power type
ACO203XL	22 – 54 mm	18,0V / 3,0Ah, battery feed
ECO301*	22 – 54 mm	220 – 240 V / 50 Hz, stationary feed
ACO401 / ACO403	76 – 108 mm	18,0V / 3,0 Ah, battery feed

* the tool is not available in the KAN-therm offer

Suitable adapters must be used to combine ACO203XL and ECO301 drives with press collars.

Depending on the diameter, KAN-therm provides various configuration of tools. In order to select optimal set of tools, please follow below chart:

TAB. 2 SELECTION OF TOOLS TABLE: SYSTEM KAN-THERM STEEL SPRINKLER & INOX SPRINKLER

Producer	Press machine		Diameter [mm]	Jaws/press collars		Adapter		Fire protection systems					
	Desc.	Code		Desc.	Code	Desc.	Code	Hydrant installations		Sprinkler installations			
								Steel Sprinkler	Inox Sprinkler	Steel Sprinkler	Inox Sprinkler		
NOVOPRESS	ACO203XL	1948267181	22	[J]M	1948267139	-	-	+	+	+	+		
			28	[J]M	1948267141	-	-	+	+	+	+		
			35	[J]M	1948267143	-	-	+	+	-	-		
			35	HP Snap ON	1948267124			+	+	+	+		
			42	M Snap ON	1948267119			+	+	-	-		
			42	HP Snap ON	1948267126	ZB203	1948267000	+	+	+	+		
			54	M Snap ON	1948267121			+	+	-	-		
			54	HP Snap ON	1948267128			+	+	+	+		
			76,1	M Snap ON	1948267145			+	+	-	-		
			88,9	M Snap ON	1948267044	ZB221	1948267005	+	+	-	-		
			108	M Snap ON	1948267038	ZB221 ZB222	1948267005 1948267007	+	+	-	-		
			EFP203	1948267210	22	[J]M	1948267139	-	-	+	+	-	-
					28	[J]M	1948267141	-	-	+	+	-	-
					35	[J]M	1948267143	-	-	+	+	-	-
					35	HP Snap ON	1948267124			+	+	-	-
	42	M Snap ON			1948267119			+	+	-	-		
	42	HP Snap ON			1948267126	ZB203	1948267000	+	+	-	-		
	54	M Snap ON			1948267121			+	+	-	-		
	54	HP Snap ON			1948267128			+	+	-	-		
	ACO102* ACO103	1948055007 1948055008	22	[J]M	1942121002	-	-	+	+	-	-		
			28	[J]M	1948267097	-	-	+	+	-	-		
			35	[J]M	1942121004	-	-	+	+	-	-		

[J] - two segment jaw, other elements are press collars and may need additional adapter to combine with press machines
* the tool is not available in the KAN-therm offer

TAB. 2 SELECTION OF TOOLS TABLE: SYSTEM KAN-THERM STEEL SPRINKLER & INOX SPRINKLER

Producer	Press machine		Diameter [mm]	Jaws/press collars		Adapter		Fire protection systems				
	Desc.	Code		Desc.	Code	Desc.	Code	Hydrant installations		Sprinkler installations		
								Steel Sprinkler	Inox Sprinkler	Steel Sprinkler	Inox Sprinkler	
NOVOPRESS	ECO301*	1948267163*	22	[J]M	1944267008	-	-	+	+	+	+	
			28	[J]M	1944267011	-	-	+	+	+	+	
			35	HP Snap ON	1948267124			+	+	+	+	
			42	HP Snap ON	1948267126	ZB303	1948267166	+	+	+	+	
			54	HP Snap ON	1948267128			+	+	+	+	
	ACO401* ACO403	1948267151 1948267209	76,1	HP	1948267100	-	-	+	+	+	+	
			88,9	HP	1948267102	-	-	+	+	+	+	
			108	HP	1948267098	-	-	+	+	+	+	
	KLAUKE	UAP100*	1948267159*	76,1	KSP3	1948267080	-	-	+	+	+	+
				88,9	KSP3	1948267082	-	-	+	+	+	+
108				KSP3	1948267074	-	-	+	+	+	+	
KAN-therm Mini		1936055008	22	[J]M	1936267278	-	-	+	+	-	-	
			28	[J]M	1936267282	-	-	+	+	-	-	
REMS	Power-Press SE Akku Press Power-Press ACC	1936267160 1942267002 1936267152	22	[J]M	1948267056	-	-	+	+	-	-	
			28	[J]M	1948267061	-	-	+	+	-	-	
			35	[J]M	1948267065	-	-	+	+	-	-	
			42	[J]M	1948267067	-	-	+	+	-	-	
			54	[J]M	1948267069	-	-	+	+	-	-	
KAN-therm	AC ECO AC 3000 DC 4000	1936267240 1936267239 1936267238	22	[J]M	1936267251	-	-	+	+	-	-	
			28	[J]M	1936267252	-	-	+	+	-	-	
			35	[J]M	1936267253	-	-	+	+	-	-	
			42	[J]M	1936267254	-	-	+	+	-	-	
			54	[J]M	1936267255	-	-	+	+	-	-	

[J] - two segment jaw, other elements are press collars and may need additional adapter to combine with press machines
* the tool is not available in the KAN-therm offer

NOVOPRESS tools:

1. Battery-powered press ACO203XL
2. PB2 M22–35 mm jaws
3. HP/M 35–108 mm Snap On collars



4. ZB203 adapter
5. ZB221, ZB222 adapters



1. EFP203 electric press
2. PB2 M22–35 mm jaws
3. HP/M 35–54 mm Snap On collars

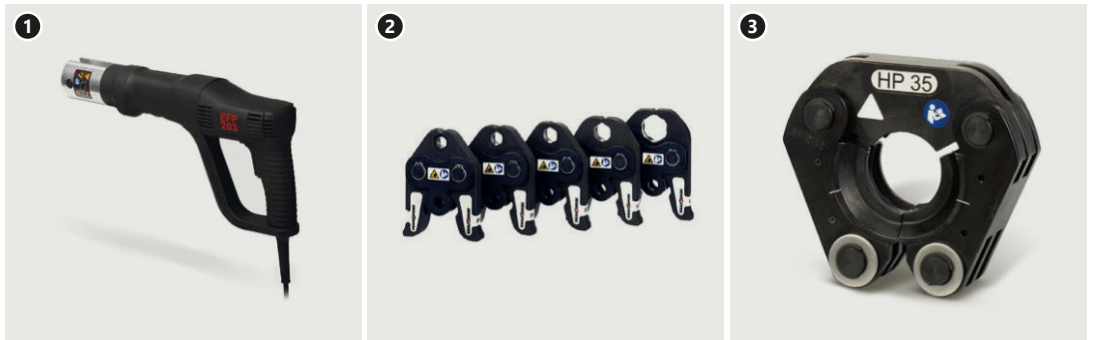

4. ZB203 adapter

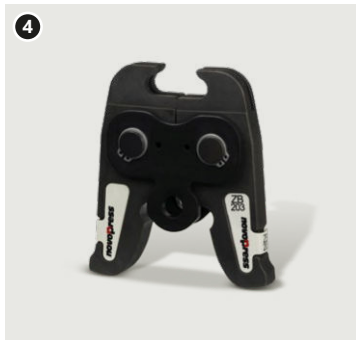

1. Battery-powered press ACO 102*
 2. Battery-powered press ACO 103
 3. M22–35 mm jaws
- * the tool is not available in the KAN-therm offer



- 1. ECO 301* electric press
- 2. PB3 M22–28 mm jaws
- 3. HP 35–54 mm Snap On collars



- 4. ZB303* adapter
- * the tool is not available in the KAN-therm offer



- 1. Battery-powered press ACO401*
- 2. Battery-powered press ACO403
- 3. HP 76,1–108 mm collars
- * the tool is not available in the KAN-therm offer

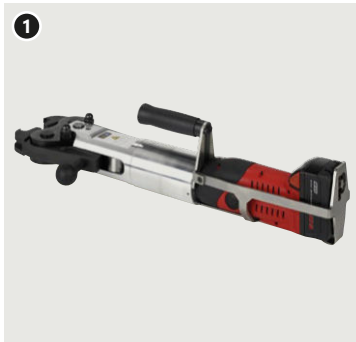

KLAUKE tools:

- 1. Battery-powered press UAP100*
- 2. 76,1–108 mm* jaws
- * the tool is not available in the KAN-therm offer

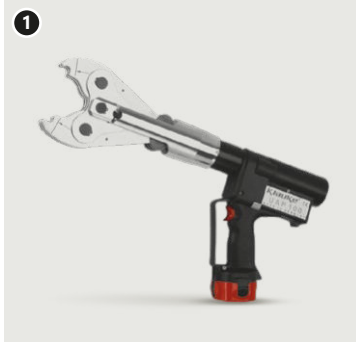

- 1. Battery-powered press KAN-therm Mini
- 2. SBM M22–28 mm jaws



REMS tools:

1. Power-Press ACC electric press
2. Battery-powered press
Akku-Press
3. Power-Press SE electric press

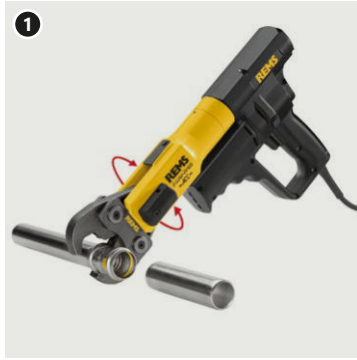

4. M22–35 mm jaws
5. M42–54 mm jaws

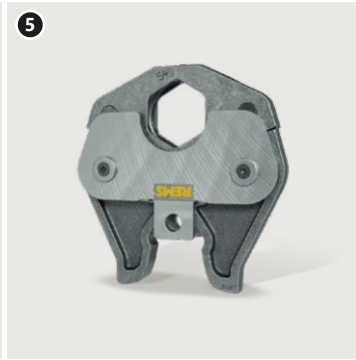
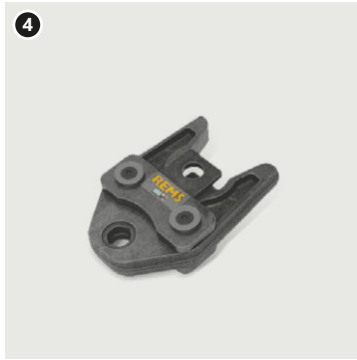

KAN-therm tools:

1. KAN-therm AC ECO electric press
2. KAN-therm AC 3000 electric press
3. KAN-therm Battery-powered press
DC 4000



4. KAN-therm M22–54 mm jaws



6 Assembly guidelines



1 Cutting pipes

Pipes must be cut perpendicularly to the axis, using pipe cutter. Cut pipes perpendicularly to the axis using a roll pipe cutter (breaking incompletely cut pipe sections is prohibited). You may also use other tools, such as hand saws and electric saws designed for cutting carbon or stainless steel, provided that the cut is made perpendicularly and the edges of the pipe are not chipped. Do not use torches or cutting discs for pipe cutting, which can generate significant amounts of heat, angle grinders, etc.



2 Beveling

Use a manual chamfer (for 76,1 – 108 diameters – a semi-round steel file) to chamfer the internal and external edge of the pipe, removing all chips, which could potentially damage the O-Ring during assembly.



3 Control

Prior to assembly, visually inspect the presence and condition of the O-Ring. Check, if there are no chips or metal shavings or other pollutions on the pipe and the fitting, which could damage the seal during installation. Make sure if the distance between neighbouring fittings is above the permissible (d_{min}) (Tab. 3, Fig. 5a).

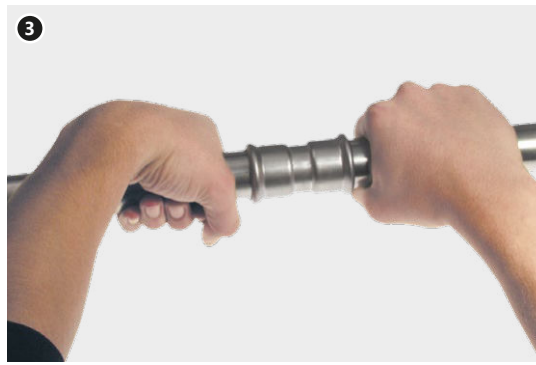

4 Installing pipe and fitting

Before pressing, insert the pipe into the fitting up to the required depth (slight rotation permissible). Do not use lubricants, greases or fats when mounting the pipe (water or a soap solution is permissible – recommended for pressure tests conducted with compressed air).

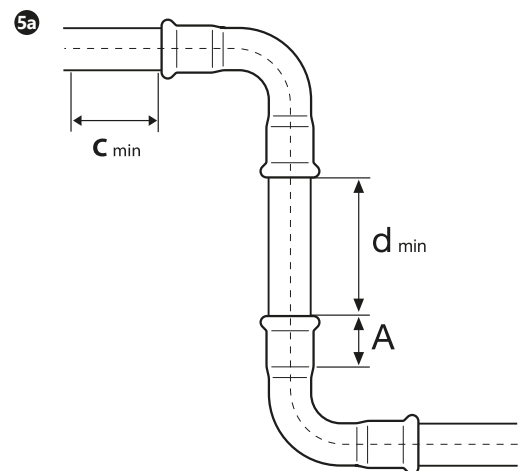

- A – pipe insert depth,
- d_{\min} – minimum distance between fittings in order to ensure correct pressing,
- c_{\min} – minimum distance of fitting from the wall.

5 Marking the insertion depth

To achieve sufficient joint strength, maintain correct insertion depth A (Tab. 3, Fig. 5a).

In the case of simultaneous assembly of many joints (sliding the pipes into the fittings) the pipe insertion depth in the fitting must be checked before pressing each subsequent joint. It is sufficient to check whether the pipe is inserted all the way.

In order to ease the identification of pipe insertion depth in the fitting the simple marking technique can be applied (not required in construction conditions).

It consists of inserting the pipe into the fitting up to the limit and making a mark on pipe with a marker, right up to the edge of the fitting socket. After pressing, the marking must be still visible but as close as possible to the fitting.

Special templates are also used for determining the insertion depth, without necessity of matching with fitting.

! Note: Insertion depth marking templates are not part of the basic system offer and may be available depending on the specific market where the product is sold.

TAB. 3 PIPE INSERT DEPTH AND MINIMUM INSTALLATION SPACES

DN	Ø external	Insert depth	Minimum distance between two pressed joints	Minimum pipe length
	[mm × mm]	A [mm]	d _{min} [mm]	d _{min} + 2×A [mm]
20	22×1,2	21	10	52
25	28×1,2	23/46*	10	62
32	35×1,5	26/52*	10	80
40	42×1,5	30/60*	20	90
50	54×1,5	35/70*	20	90
65	76,1×2,0	55/54*	40	165
80	88,9×2,0	63/64*	50	186
100	108×2,0	77/74*	60	234

* applies to Groove type couplings

TAB. 4 INSTALLATION DISTANCES

DN	Ø external	Fig. A		Fig. B			Fig. C
	[mm × mm]	a	b	a	b	c	L - Pipe stand-off from wall distance [mm]
20	22×1,2	65	25	80	31	35	40
25	28×1,2	75	25	80	31	35	60
32*	35×1,5	115	75	115	75	75	70
40*	42×1,5	120	75	115	75	75	70
50*	54×1,5	200	85	120	85	85	70
65*	76,1×2,0	250	170	200	170	190	80
80*	88,9×2,0	250	170	250	170	210	90
100*	108×2,0	250	170	250	170	210	100

* applies to press collars

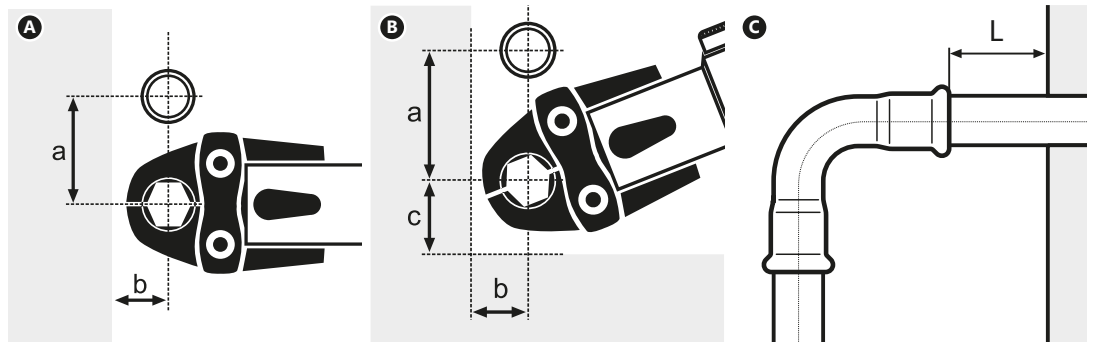



6 Pressing

Before starting any works, verify the proper operation of your tools. Use press tools and jaws recommended by KAN.

Select the size of your press jaw basing on the diameter of the joint. Place the jaws on the joint so that its notch embraces the protruding part of the fitting (the space where the O-Ring is located). After starting the press, the process takes place automatically and cannot be stopped. If, for any reason, the process of pressing is stopped, the joint needs to be disassembled (cut off) and a new one needs to be executed. If the installer has press tools and jaws not supplied by the KAN-therm, the possibility of using them should be consulted with KAN.

Pipe bending (for diameters up to Ø28)

If needed, „cold“ bending may be performed, on the condition of maintaining minimum bend radius:

$$R_{\min} \geq 3,5 \times D$$

For greater diameters use available system bends and elbows.

For pipes bending, use manual, hydraulic or electrical bender. The pipes should not be „hot“ bent.

6.1 Threaded connections

KAN-therm Sprinkler system also includes external and internal thread elements, which serve the purpose of connecting other threaded elements of the system (such as sprinklers, valves or other). External and internal threads are manufactured according to DIN 2999 / ISO 7/1 (taper thread). It is recommended to perform threaded connection before pressing the fitting, not to stress the pressed joint.

7 General information regarding system installation

7.1 Fitting pipelines

While installing KAN-therm Sprinkler system, care must be taken not to overstress the pipelines network, while standby, as well as during an emergency. A/C channels or cable racks should not be placed above the sprinkler pipe.

In case if design or structural reasons make it impossible to avoid the sprinkler pipe crossing other system elements, such as A/C channels or cable racks, the sprinkler system should be secured from over stressing, using additional, certified fixture elements.

The required space between fixtures is provided in the table. Fixture distance from pipe ending must not exceed 90 cm.

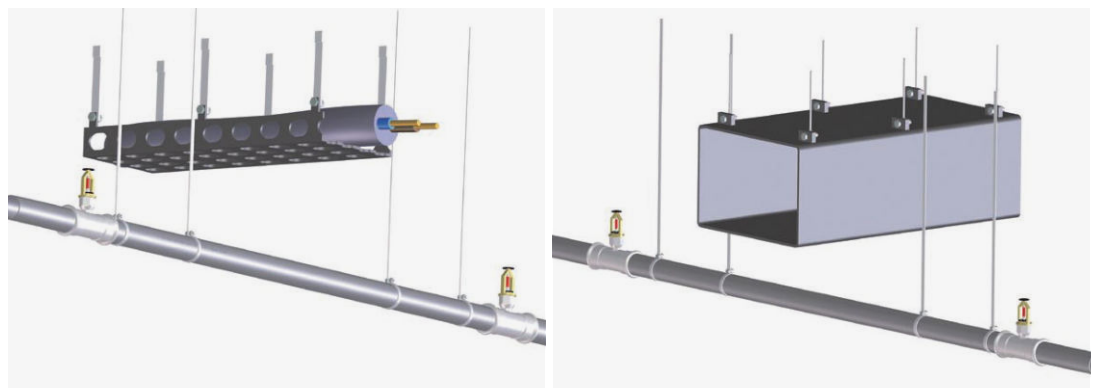

DN	Pipe dimensions Ø [mm] external	Max clamp spacing [m]	
		DIN 1988-2	CEA 4001 (VdS)
20	22	2	2
25	28	2,25	2
32	35	2,75	2
40	42	3	2
50	54	3,5	2
65	76,1	4,25	2
80	88,9	4,75	2
100	108	5	2

KAN-therm Sprinkler maximal clamp distances apply only, if there are no other installations (pipelines, channels) above the sprinkler system pipe.

There should be at least one clamp within at least 0,9 m from each joint. Each pipe section should be held by at least one clamp.

Clamps and supports must be designed and constructed in conformity with EN 12845.

7.2 Pipeline flushing

After performing the installation, the entire sprinkler system must be thoroughly flushed with treated water. The flushing is necessary for assuring proper operation of the sprinkler system and protecting it from contamination. After flushing, the installation should be emptied. After removing all materials required for flushing, sprinklers should be installed.

Filling and deaerating pipe networks

After flushing the pipelines, they must be filled with filtered drinking water and completely deaerated. After rinsing and draining the installation performed using KAN-therm Steel Sprinkler it should be immediately filled with filtered water again in order to protect against possible corrosion.

8 Tightness test

Pipelines of the sprinkler system must be pressure tested, in conformity with applicable guidelines, such as CEA 4001, no. 17.1.1. (VdS). The test should last at least two hours at a pressure (measured at emergency valves) being a 1,5 multiple of admissible operating pressure, but not smaller than 15 bar.

Pressure decrease, e.g. due to meteorological factors, must be monitored at 24h basis.

Dry sprinkler installations must be pneumatically tested for pressure not smaller than 2,5 bar for a period of at least 24 hours. Each leak that causes a decrease of pressure greater than 0,15 bar for a period of at least 24 h, must be sealed. All detected defects, such as permanent deformations, breaks or leaks must be fixed and be tested again. During pneumatic test all leaks may be localized acoustically or utilizing foaming agents approved for contact with EPDM gaskets.

Hydrant installations should be pressure tested identically like potable water systems: test pressure = 1,5x admissible operating pressure but not less than 10 bar.

9 Transport and storage

- When transporting and storing KAN-therm Sprinkler system pipes and pressed fittings, they should be kept away from damage or contamination hazards.
- KAN-therm Sprinkler system elements should not be stored together with elements of other metal systems.
- It is not allowed to store system elements directly on the ground (concrete or earth).
- It is not allowed to store the elements in direct vicinity of chemical compounds.
- Pipe bundles should be stored and transported on wooden or plastic pads (avoid direct contact with other steel elements, such as steel pipe racks). To avoid ovalization of pipes, it is recommended to form piles not higher than 6 bundles. During transport, loading and unloading, avoid scratching or else mechanically damaging pipes and fittings - do not: throw, pull and bend.
- Rooms for storing the elements must be dry (maximum permissible relative humidity must not exceed 65%). Recommended temperature for storage is in the range of 10 to 25 °C.
- External pipe surfaces during storage, construction and operation must not be exposed to extensive and direct contact with humidity.

10 General hydraulic dimensioning guidelines for **KAN-therm** Sprinkler systems

Pressure losses

To calculate pressure loss in pipe network of sprinkler systems, Hazen-Williams formula should be applied.

$$p = \frac{6,05 \times 10^5}{C^{1,85} \times d^{4,87}} \times Q^{1,85} \times L$$

where:

p – linear pressure loss [bar]

Q – flow intensity [l/min]

d – internal pipe diameter

C – pipe constant, for KAN-therm Steel and Inox Sprinkler systems C = 140

L – substitute length for pipes and fittings [m]

The formula covers linear losses on the length of the calculated section of the pipelines, as well as local losses in form of equivalent (substitute) lengths for fittings and fixtures (values of substitute lengths for fittings are shown in table below).

Designing and hydraulic dimensioning principles for sprinkler systems are defined by PN-EN 12845 standard. Stationary fire extinguishing units. Automatic sprinkler systems. Design, assembly and maintenance.



Ø 22 – 54 mm									
Local resistance coefficients ζ									
ζ	1,5	0,7	0,5	0,5	0,4	0,9	1,3	1,5	3
Equivalent lengths of fittings [m]									
22	1,40	0,60	0,50	0,50	0,40	0,80	1,20	1,40	2,80
28	1,90	0,90	0,60	0,60	0,50	1,10	1,50	1,90	3,80
35	2,50	1,20	0,80	0,80	0,70	1,50	2,10	2,50	5,00
42	3,10	1,40	1,00	1,00	0,90	1,80	2,60	3,10	6,20
54	4,00	1,80	1,30	1,30	1,10	2,30	3,30	4,00	8,00
Ø 76,1 – 108 mm									
Local resistance coefficients ζ									
ζ	1,3	0,6	0,4	0,5	0,1	1,0	1,3	1,5	3,0
Equivalent lengths of fittings [m]									
76,1	6,10	2,80	1,90	2,40	0,50	4,70	6,10	7,10	14,20
88,9	7,80	3,60	2,40	3,00	0,60	6,00	7,80	9,00	18,00
108	10,60	4,90	3,30	4,10	0,80	8,20	10,60	12,30	24,60

TAB. 5 PRESSURE LOSSES IN ELASTIC HOSES AND EQUIVALENT PIPE LENGTHS CORRESPONDING TO VDS SPECIFICATIONS

Length	Sprinkler joint type	Sprinkler connector	Ø external	Pressure losses	Equiv. pipe length
[mm]			[mm]	[bar]	[m]
1000	straight	Rp 1/2"	Ø22	0,9	8
1500	straight	Rp 1/2"	Ø22	1,3	12
1000	straight	Rp 1/2"	Ø28	0,5	8
1500	straight	Rp 1/2"	Ø28	0,8	11
800	degree 90°	Rp 1/2"	Ø22	0,8	8
1000	degree 90°	Rp 1/2"	Ø22	0,9	8
1500	degree 90°	Rp 1/2"	Ø22	1,3	12
800	degree 90°	Rp 1/2"	Ø28	0,5	8
1000	degree 90°	Rp 1/2"	Ø28	0,5	8
1500	degree 90°	Rp 1/2"	Ø28	0,8	11

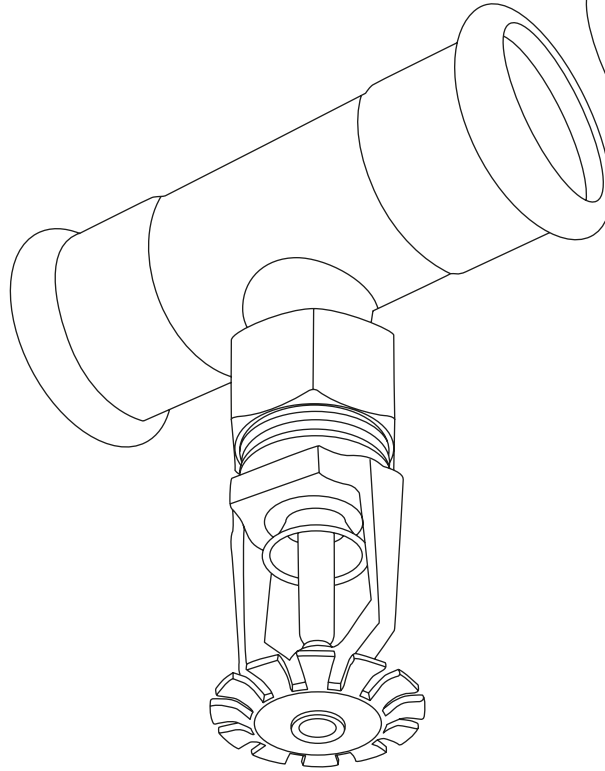

SYSTEM **KAN-therm**

Steel Sprinkler

1 Application and operating conditions

KAN-therm Steel Sprinkler system is designed for constructing pipelines (distributing or pipe branches) of stationary wet (permanently filled with water) sprinkler systems installed in small or medium fire hazard areas (LH, OH1, OH2, OH3 and up to OH4 - in reference to exhibition rooms, theatres and concert halls) (according to VdS CEA 4001 guidelines).

KAN-therm Steel Sprinkler is also suitable for performing indoor, permanently filled with water, non-flow* (until fire fighting action), fully separated or single-side connected to potable water system hydrant installations.

Application in other fire extinguishing systems and dry sprinkler systems is prohibited.

* As non-flow hydrant installations with no intake points other than hydrant valves are understood, and the water flow occurs only during the fire fighting operation and / or annual performance tests, in accordance with EN 671-3 Fixed fire fighting equipment. Internal hydrants. Part 3: Maintenance of indoor hydrants with semi-rigid hose and indoor hydrants with flat folded hose.

System pipes and fittings hold certificates issued by Fire Protection Scientific Research Centre CNBOP and VdS certificate.

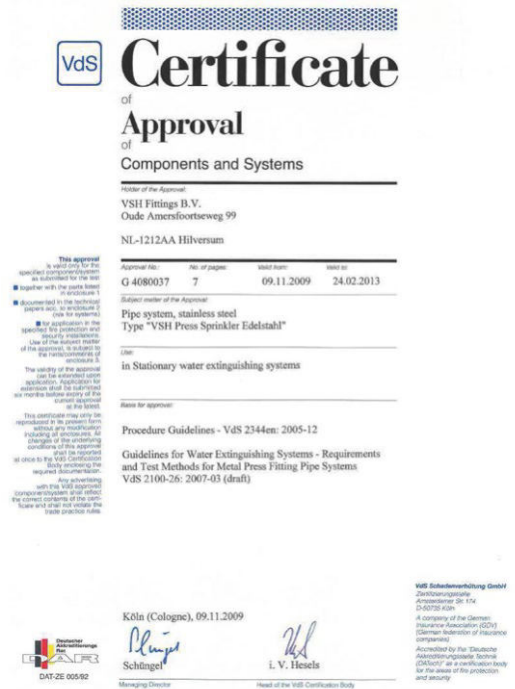

The installation should be designed and constructed according to guidelines included in this document, as well as with applicable standards and regulations.

Designing, assembly and commissioning of the sprinkler system is defined by EN 12845 standard. Stationary fire extinguishing units. Automatic sprinkler units. Design, assembly and maintenance.

Maximum operating pressure of the pipes and fittings is:

- for 22–54 mm diameters 16,0 bar,
- for 76,1 mm diameter 12,5 bar,
- for 88,9 mm and 108 diameters 10,0 bar.

2 KAN-therm Steel Sprinkler system - carbon steel pipes



KAN-therm Steel Sprinkler system pipes for water sprinkler installations are precise carbon steel no. 1.0031 (EN 10305-3 compliant) pipes. They are made of cold rolled strip, galvanized using the Sendzimir method of coating the metal plate with zinc by immersing it in electrolytic zinc, after which the zinc is applied on both sides simultaneously. This means the pipe is protected by zinc layer on inside and outside. The zinc layer is never less than 20 μm thick. The Sendzimir galvanization is known for guaranteeing particularly good adherence and high resistance to corrosion.

Fire environment properties

KAN-therm Steel Sprinkler system carbon steel pipes may be classified as class A incombustible materials, according to DIN 4102, part 1.

TAB. 1 TECHNICAL DETAILS OF PIPES

DN	External diameter × wall thickness	Internal diameter	Unit mass	Water capacity
	mm × mm	[mm]	[kg/m]	[kg/m]
20	22 × 1,5	19,0	0,761	0,284
25	28 × 1,5	25,0	0,980	0,491
32	35 × 1,5	32,0	1,241	0,804
40	42 × 1,5	39,0	1,542	1,195
50	54 × 1,5	51,0	1,999	2,043
65	76,1 × 2,0	72,1	3,503	4,083
80	88,9 × 2,0	84,9	4,412	5,661
100	108 × 2,0	104,0	5,382	8,495

TAB 2. KAN-THERM STEEL SPRINKLER PIPES FOR FIRE FIGHTING INSTALLATIONS

Material	ULC („Ultra Light Carbon“) galvanized (Sendzimir method) material no. 1.0031 acc. to EN 10305-3
External diameter tolerance	acc. to EN 10305-3
Thermal expansion coefficient	0,0108 mm/m at $\Delta T = 1K$
Minimum bend radius (for diameters up to Ø28 mm)	3,5 × external pipe diameter (up to -10°C)
Delivery	6 m ± 50 mm lengths
Marking	name or manufacturer label, material identification, outside diameter x wall thickness, approval no., manufacture date
Zinc layer	at least 20 µm. The pipe joints are extra galvanized.
Max. operating pressure	16 bar (22–54 mm); 12,5 bar (76,1 mm); 10 bar (88,9–108 mm)

3 KAN-therm Steel Sprinkler system - pressed carbon steel couplings

KAN-therm Steel Sprinkler system pressed couplings are made of material no. 1.0034 [34-2 steel] carbon steel. They are rust protected by the applied zinc layer (8-15 µm). The couplings are equipped with EPDM rubber sealing ring (O-Ring). The DN20–DN50 O-Rings feature non-pressed joints detection function LBP (Leak Before Press).

Coupling diameter range DN20–DN100



SYSTEM KAN-therm Steel Sprinkler

Pipes

Zinc coated carbon steel pipe - bar 6 m

GROUP: J



Size	Code	*			UM
22×1,5	1530207013		6	360	m
28×1,5	1530207014		6	222	m
35×1,5	1530207016		6	222	m
42×1,5	1530207018		6	114	m
54×1,5	1530207020		6	114	m
76,1×2,0	1530207022		6	222	m
88,9×2,0	1530207010		6	96	m
108×2,0	1530207024		6	78	m

coil bar pipes in tube bag carton box pallet new available soon

* on request (delivery time up to 4 weeks) | ** availability by individual arrangements | *** till stock ends

Fittings

Male connector

GROUP: I

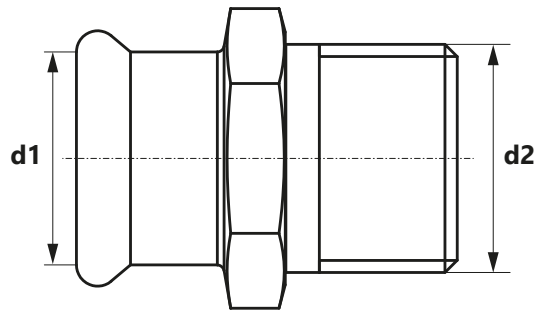

Size (d1 × d2)	Code	*			UM
22 R1/2"	1511045002		10	70	pc.
22 R3/4"	1511045003		10	100	pc.
22 R1"	1511045001		10	60	pc.
28 R3/4"	1511042000		10	60	pc.
28 R1"	1511045004		10	60	pc.
35 R1"	1509045021		10	40	pc.
35 R1 1/4"	1511045005		5	40	pc.
42 R1 1/2"	1511045006		4	24	pc.
54 R2"	1511045007		4	12	pc.
76,1 R2 1/2"	1511045000		2	26	pc.
88,9 R3"	1511045008		2	20	pc.

Male union connector

GROUP: I

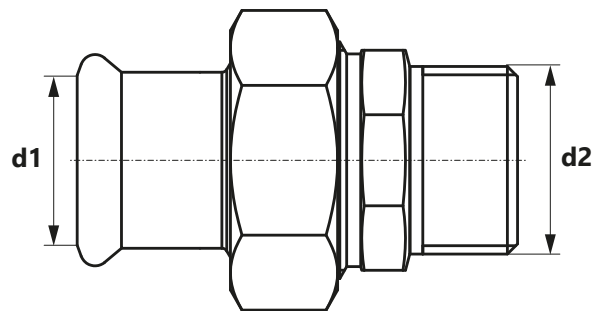

Size (d1 × d2)	Code	*			UM
22 R3/4"	1511272000		2	40	pc.
28 R1"	1511272001		2	30	pc.
35 R1 1/4"	1511272002		2	16	pc.
42 R1 1/2"	1511272003		2	12	pc.
54 R2"	1511272004		2	4	pc.

coil
 bar
 pipes in tube
 bag
 carton box
 pallet
 new
 available soon

* on request (delivery time up to 4 weeks) | ** availability by individual arrangements | *** till stock ends

Female half union with flat gasket

GROUP: I

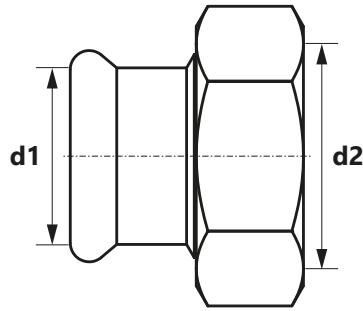

Size (d1 × d2)	Code	*			UM
22 G1"	1511050001		10	60	pc.
28 G1¼"	1511050002		10	40	pc.
35 G1½"	1511050003		4	32	pc.
42 G1¾"	1511050004		4	12	pc.
54 G2 ⅜"	1511050005		4	8	pc.

Female connector

GROUP: I

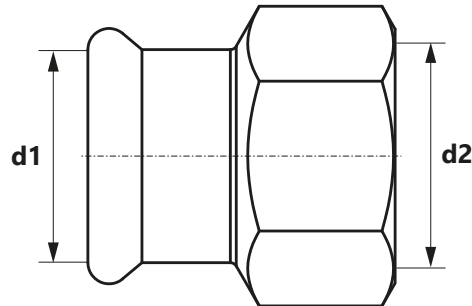

Size (d1 × d2)	Code	*			UM
22 Rp½"	1509044042		10	100	pc.
22 Rp¾"	1511044001		10	100	pc.
28 Rp½"	1511044006		10	60	pc.
28 Rp¾"	1511044005		10	60	pc.
28 Rp1"	1511044002		10	60	pc.
35 Rp½"	1511044000		10	40	pc.
35 Rp¾"	1511044011		10	40	pc.
35 Rp1"	1509044029		10	40	pc.
35 Rp¼"	1511044007		10	30	pc.
42 Rp½"	1511044003		4	24	pc.
54 Rp2"	1511044004		4	12	pc.

coil
 bar
 pipes in tube
 bag
 carton box
 pallet
 new
 available soon

* on request (delivery time up to 4 weeks) | ** availability by individual arrangements | *** till stock ends

Female nipple connector

GROUP: I

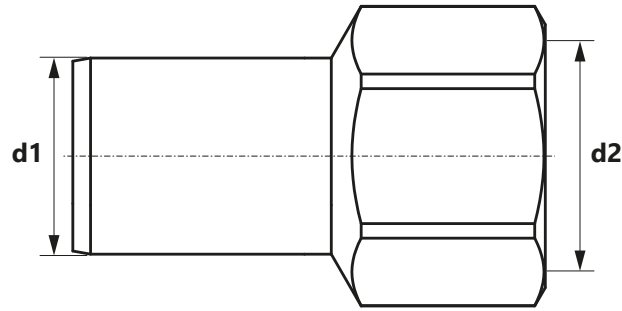

Size (d1 × d2)	Code	*			UM
22 Rp½"	1511076000		10	70	pc.
22 Rp¾"	1511076001		10	100	pc.

Coupling

GROUP: I

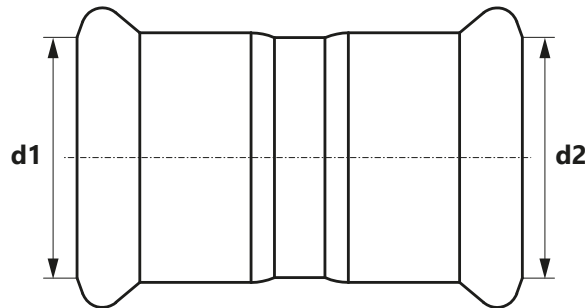

Size (d1 × d2)	Code	*			UM
22	1511245001		10	80	pc.
28	1511245002		10	60	pc.
35	1511245003		5	40	pc.
42	1511245004		4	24	pc.
54	1511245005		4	16	pc.
76,1	1511245006		4	24	pc.
88,9	1511245007		4	16	pc.
108	1511245000		2	10	pc.

coil
 bar
 pipes in tube
 bag
 carton box
 pallet
 new
 available soon

* on request (delivery time up to 4 weeks) | ** availability by individual arrangements | *** till stock ends

Slip coupling

GROUP: I

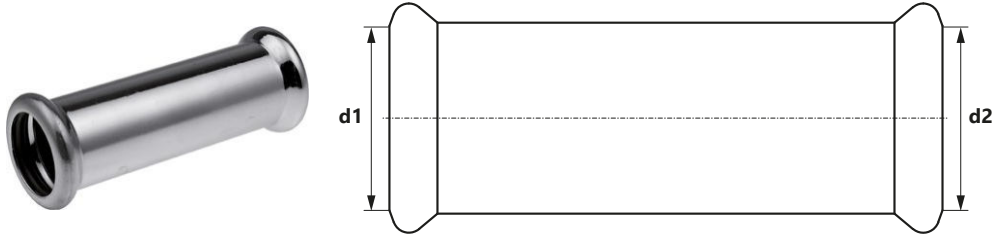

Size (d1=d2)	Code	*			UM
22	1511080001		10	60	pc.
28	1511080002		5	40	pc.
35	1511080003		5	20	pc.
42	1511080004		4	16	pc.
54	1511080005		2	8	pc.
76,1	1511080006		2	16	pc.
88,9	1511080007		2	6	pc.
108	1511080000		-	2	pc.

Elbow 90°

GROUP: I

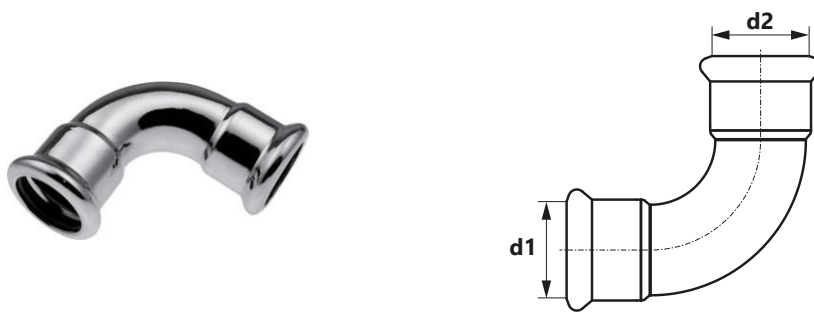

Size (d1=d2)	Code	*			UM
22	1511068020		10	60	pc.
28	1511068021		5	30	pc.
35	1511068022		5	20	pc.
42	1511068023		2	8	pc.
54	1511068024		2	8	pc.
76,1	1511068025		2	10	pc.
88,9	1511068026		2	8	pc.
108	1511068019		2	4	pc.

coil
 bar
 pipes in tube
 bag
 carton box
 pallet
 new
 available soon

* on request (delivery time up to 4 weeks) | ** availability by individual arrangements | *** till stock ends

Nipple elbow 90°

GROUP: I

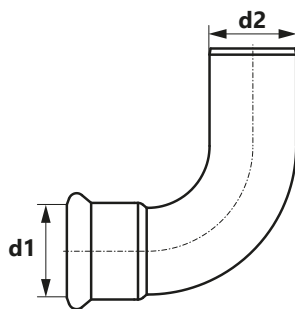

Size (d1=d2)	Code	*			UM
22	1511068028		10	60	pc.
28	1511068029		5	30	pc.
35	1511068030		5	20	pc.
42	1511068031		2	8	pc.
54	1511068032		2	6	pc.
76,1	1511068033		2	12	pc.
88,9	1511068034		2	4	pc.
108	1511068027		2	4	pc.

Elbow 45°

GROUP: I

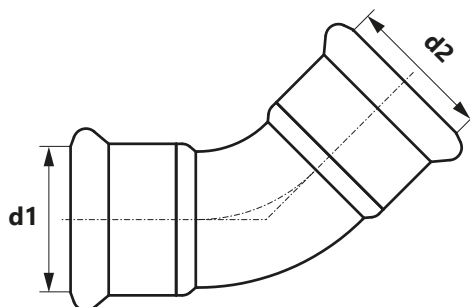

Size (d1=d2)	Code	*			UM
22	1511068004		10	70	pc.
28	1511068005		10	40	pc.
35	1511068006		5	25	pc.
42	1511068007		4	16	pc.
54	1511068008		2	8	pc.
76,1	1511068009		2	16	pc.
88,9	1511068010		2	8	pc.
108	1511068003		2	6	pc.

coil
 bar
 pipes in tube
 bag
 carton box
 pallet
 new
 available soon

* on request (delivery time up to 4 weeks) | ** availability by individual arrangements | *** till stock ends

Nipple elbow 45°

GROUP: I

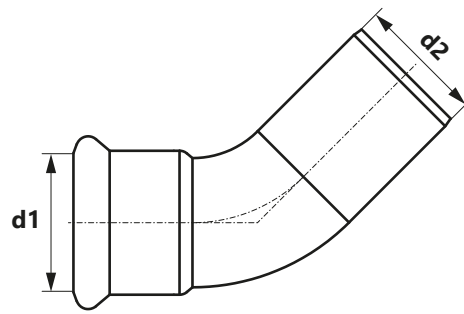

Size (d1=d2)	Code	*			UM
22	1511068012		10	60	pc.
28	1511068013		10	40	pc.
35	1511068014		5	25	pc.
42	1511068015		4	16	pc.
54	1511068016		2	8	pc.
76,1	1511068017		2	14	pc.
88,9	1511068018		2	12	pc.
108	1511068011		2	6	pc.

Tee

GROUP: I

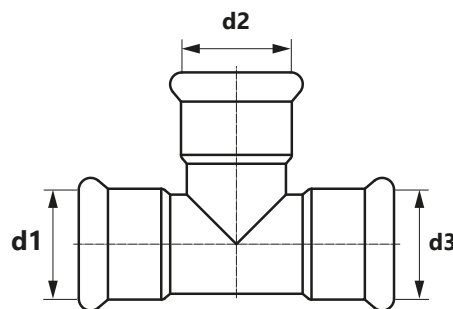

Size (d1=d2=d3)	Code	*			UM
22	1511257001		10	40	pc.
28	1511257002		5	25	pc.
35	1511257003		5	15	pc.
42	1511257004		4	8	pc.
54	1511257005		2	6	pc.
76,1	1511257006		2	8	pc.
88,9	1511257007		2	6	pc.
108	1511257000		2	2	pc.

coil
 bar
 pipes in tube
 bag
 carton box
 pallet
 new
 available soon

* on request (delivery time up to 4 weeks) | ** availability by individual arrangements | *** till stock ends

Reducing tee

GROUP: I

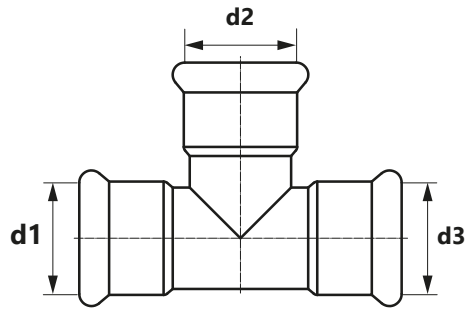

Size (d1/d2/d3)	Code	*			UM
22 / 28 / 22	1511260007		5	30	pc.
28 / 22 / 28	1511260008		5	30	pc.
35 / 22 / 35	1511260009		5	20	pc.
35 / 28 / 35	1511260010		5	20	pc.
42 / 22 / 42	1511260011		4	12	pc.
42 / 28 / 42	1511260012		4	12	pc.
42 / 35 / 42	1511260013		4	12	pc.
54 / 22 / 54	1511260014		2	8	pc.
54 / 28 / 54	1511260015		2	8	pc.
54 / 35 / 54	1511260016		2	8	pc.
54 / 42 / 54	1511260017		2	8	pc.
76,1 / 22 / 76,1	1509260043		2	14	pc.
76,1 / 28 / 76,1	1511260018		2	14	pc.
76,1 / 35 / 76,1	1511260019		2	14	pc.
76,1 / 42 / 76,1	1511260020		2	12	pc.
76,1 / 54 / 76,1	1511260021		2	8	pc.
88,9 / 22 / 88,9	1509260053		2	8	pc.
88,9 / 28 / 88,9	1511260025		2	6	pc.
88,9 / 35 / 88,9	1509260051		2	6	pc.
88,9 / 42 / 88,9	1511260022		2	8	pc.
88,9 / 54 / 88,9	1511260023		2	6	pc.
88,9 / 76,1 / 88,9	1511260024		2	6	pc.
108 / 22 / 108	1511260000		2	6	pc.
108 / 28 / 108	1511260001		2	4	pc.
108 / 35 / 108	1511260002		2	6	pc.
108 / 42 / 108	1511260003		2	6	pc.
108 / 54 / 108	1511260004		2	6	pc.
108 / 76,1 / 108	1511260005		2	4	pc.
108 / 88,9 / 108	1511260006		2	2	pc.

coil
 bar
 pipes in tube
 bag
 carton box
 pallet
 new
 available soon

* on request (delivery time up to 4 weeks) | ** availability by individual arrangements | *** till stock ends

Pipe cross

GROUP: I

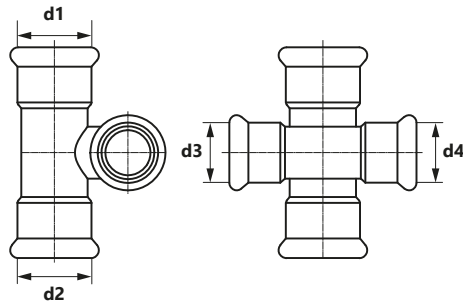

Size (d1=d2/d3=d4)	Code	*							UM
28 / 22	1511057000		5				20		pc.

Crossing

GROUP: I

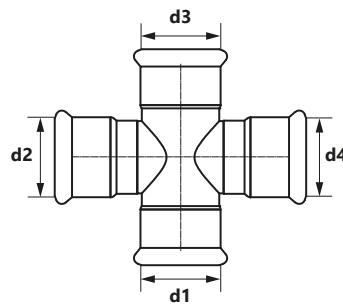

Size (d1=d3/d2=d4)	Code	*							UM
35	1511057002		2				8		pc.
42	1511057003		2				8		pc.
54	1511057004		-				4		pc.
35 / 28	1511057005		2				14		pc.
42 / 28	1511057006		2				8		pc.
54 / 28	1511057001		2				4		pc.

coil
 bar
 pipes in tube
 bag
 carton box
 pallet
 new
 available soon

* on request (delivery time up to 4 weeks) | ** availability by individual arrangements | *** till stock ends

Nipple reducer

GROUP: I

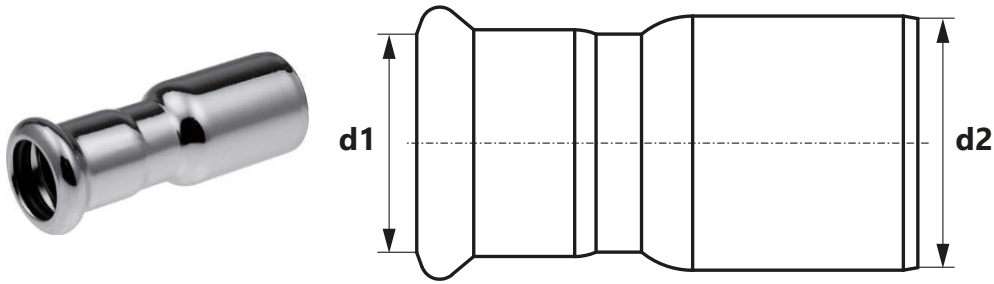

Size (d1/d2)	Code	*			UM
28 / 22	1511221006		10	80	pc.
35 / 22	1511221007		5	50	pc.
35 / 28	1511221008		5	60	pc.
42 / 22	1511221013		4	24	pc.
42 / 28	1511221014		4	24	pc.
42 / 35	1511221009		4	24	pc.
54 / 22	1511221010		4	16	pc.
54 / 28	1511221011		4	16	pc.
54 / 35	1511221015		4	16	pc.
54 / 42	1511221012		4	16	pc.
76,1 / 42	1511221002		4	4	pc.
76,1 / 54	1511221003		4	40	pc.
88,9 / 54	1511221004		4	32	pc.
88,9 / 76,1	1511221005		4	16	pc.
108 / 76,1	1511221000		2	10	pc.
108 / 88,9	1511221001		2	10	pc.

Female slip connector

GROUP: I

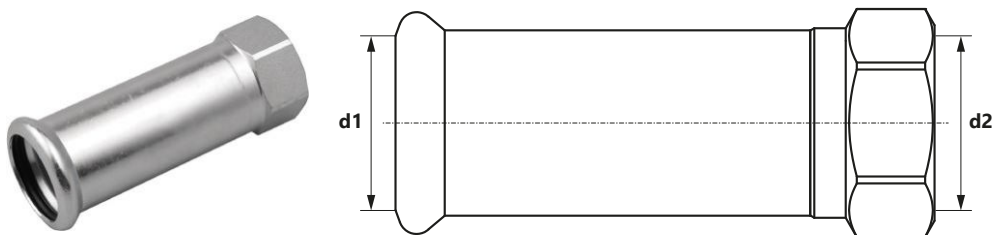

Size (d1 × d2)	Code	*			UM
22 Rp½"	1511044008		10	60	pc.
22 Rp¾"	1511044009		10	60	pc.
28 Rp½"	1611042018		10	40	pc.
28 Rp¾"	1511044010		10	40	pc.

coil
 bar
 pipes in tube
 bag
 carton box
 pallet
 new
 available soon

* on request (delivery time up to 4 weeks) | ** availability by individual arrangements | *** till stock ends

Male elbow 90°

GROUP: I

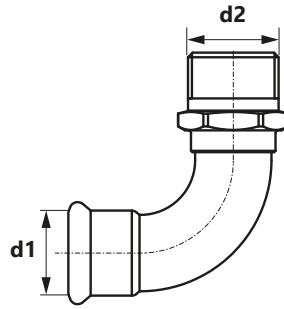

Size (d1 × d2)	Code	*			UM
22 R¾"	1511070000		10	50	pc.
28 R1"	1511070001		5	30	pc.
35 R1¼"	1511070002		5	10	pc.
42 R1½"	1511070003		2	12	pc.
54 R2"	1511070004		2	8	pc.

Short male elbow 90°

GROUP: I

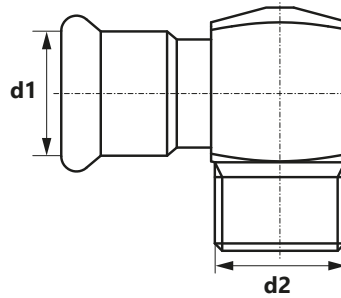

Size (d1 × d2)	Code	*			UM
22 R¾"	1511070005		10	60	pc.

coil
 bar
 pipes in tube
 bag
 carton box
 pallet
 new
 available soon

* on request (delivery time up to 4 weeks) | ** availability by individual arrangements | *** till stock ends

Female elbow 90°

GROUP: I

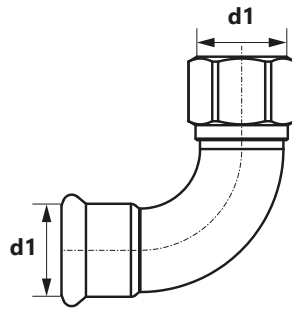

Size (d1 × d2)	Code	*			UM
22 Rp1/2"	1511068000		10	50	pc.
22 Rp3/4"	1511068001		10	50	pc.
28 Rp1/2"	1511069000		5	30	pc.
28 Rp3/4"	1511069001		5	30	pc.
28 Rp1"	1511069002		5	30	pc.
35 Rp1/2"	1511069003		5	10	pc.
35 Rp3/4"	1511069004		5	10	pc.
35 Rp1"	1511068002		5	20	pc.

Short female elbow 90°

GROUP: I

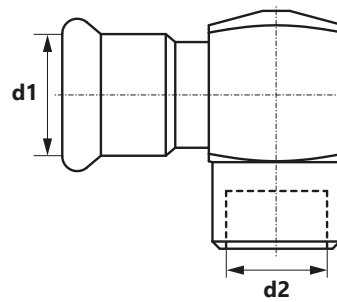

Size (d1 × d2)	Code	*			UM
22 R1/2"	1511069006		10	50	pc.
28 R1/2"	1511069005		5	30	pc.
35 R1/2"	1511069007		5	10	pc.

coil
 bar
 pipes in tube
 bag
 carton box
 pallet
 new
 available soon

* on request (delivery time up to 4 weeks) | ** availability by individual arrangements | *** till stock ends

Female tee

GROUP: I

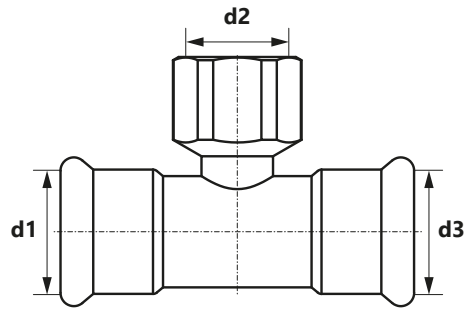

Size (d1=d3×d2)	Code	*			UM
22 Rp½"	1511258003		10	50	pc.
22 Rp¾"	1511258002		10	40	pc.
28 Rp½"	1511258004		5	30	pc.
28 Rp¾"	1511258005		5	30	pc.
28 Rp1"	1511257008		5	30	pc.
35 Rp½"	1511258006		5	20	pc.
35 Rp¾"	1511258007		5	20	pc.
35 Rp1"	1511257009		5	20	pc.
42 Rp½"	1511258008		4	16	pc.
42 Rp¾"	1511258009		4	12	pc.
42 Rp1"	1511257010		4	12	pc.
54 Rp½"	1511258010		2	8	pc.
54 Rp¾"	1511258011		2	8	pc.
54 Rp1"	1511258000		2	8	pc.
76,1 Rp¾"	1511258012		2	12	pc.
88,9 Rp¾"	1511258013		2	8	pc.
108 Rp¾"	1511258001		-	2	pc.

Crossover

GROUP: I

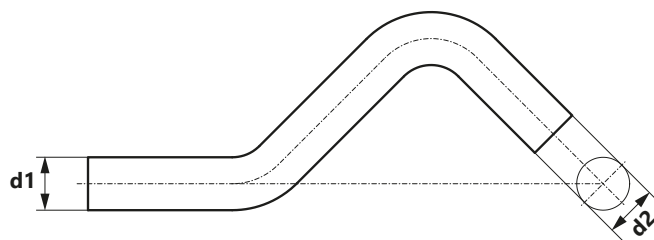

Size (d1=d2)	Code	*			UM
22	1511022000		10	40	pc.
28	1511022001		5	20	pc.

coil
 bar
 pipes in tube
 bag
 carton box
 pallet
 new
 available soon

* on request (delivery time up to 4 weeks) | ** availability by individual arrangements | *** till stock ends

Bend 90°

GROUP: I

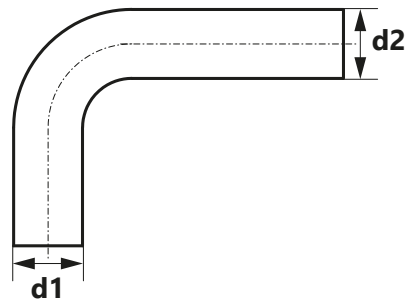

Size (d1=d2)	Code	*			UM
22	1511011000		10	30	pc.
28	1511011001		5	20	pc.
35	1511011002		2	8	pc.
42	1511011003		2	4	pc.
54	1511011004		-	2	pc.

Flange PN16

GROUP: I

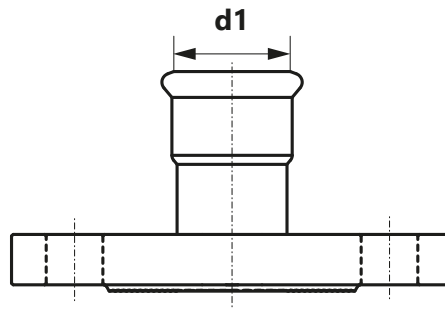

Size (d1)	Code	*			UM
76,1 DN65	1511091002		1	4	pc.
88,9 DN80	1511091003		1	2	pc.
108 DN100	1511091001		1	2	pc.

coil
 bar
 pipes in tube
 bag
 carton box
 pallet
 new
 available soon

* on request (delivery time up to 4 weeks) | ** availability by individual arrangements | *** till stock ends

Stop end

GROUP: I

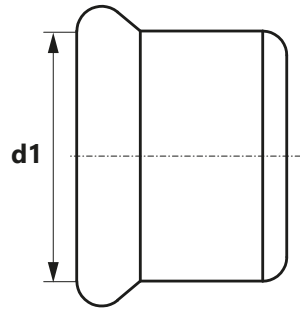

Size (d1)	Code	*			UM
22	1511250001		10	150	pc.
28	1511250002		10	130	pc.
35	1511250003		5	75	pc.
42	1511250004		4	48	pc.
54	1511250005		4	32	pc.
76,1	1511250006		2	20	pc.
88,9	1511250007		2	4	pc.
108	1511250000		2	4	pc.

Coupling Steel Sprinkler/Groove

GROUP: I

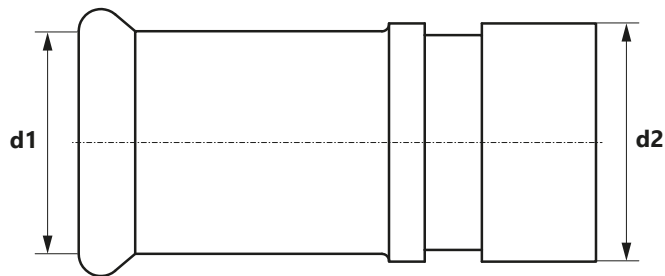

Size (d1/d2)	Code	*			UM
28 / 33,7	1511042001		10	30	pc.
35 / 42,4	1511042002		10	30	pc.
42 / 48,3	1511042003		5	20	pc.
54 / 60,3	1511042004		5	15	pc.
76,1	1511042006		2	-	pc.
88,9	1511042007		2	-	pc.
108 / 114	1511042005		2	-	pc.

coil
 bar
 pipes in tube
 bag
 carton box
 pallet
 new
 available soon

* on request (delivery time up to 4 weeks) | ** availability by individual arrangements | *** till stock ends

Flexible hose with straight ending

GROUP: G

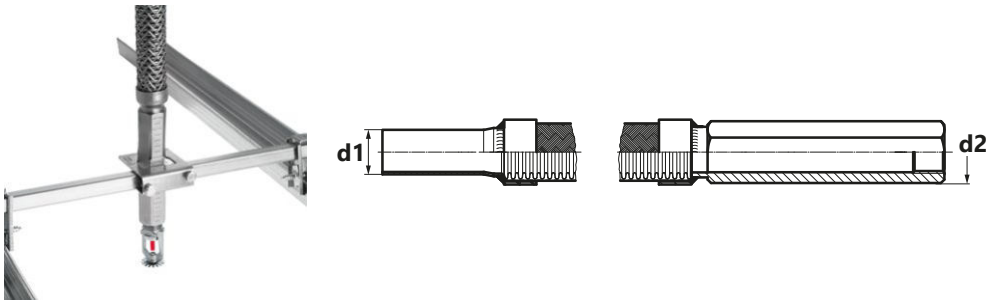

Size (d1×d2×l)	Code	*			UM
22 Rp½" 1000 mm	1611289001	-	-	10	pc.
22 Rp½" 1500 mm	1511289005	-	-	10	pc.
22 Rp½" 2000 mm	1511289006	-	-	10	pc.
28 Rp½" 1000 mm	1511289007	-	-	10	pc.
28 Rp½" 1500 mm	1511289008	-	-	10	pc.
28 Rp½" 2000 mm	1511289009	-	-	10	pc.

Flexible hose with angle ending

GROUP: G

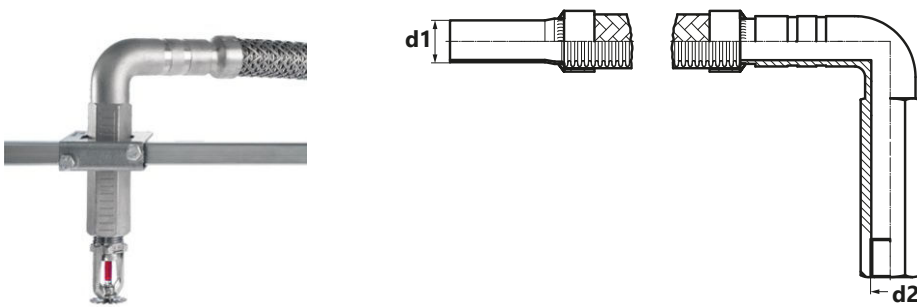

Size (d1×d2×l)	Code	*			UM
22 Rp½" 800 mm	1511289000	-	-	10	pc.
22 Rp½" 1000 mm	1611289000	-	-	10	pc.
28 Rp½" 800 mm	1511289002	-	-	10	pc.
28 Rp½" 1500 mm	1511289004	-	-	10	pc.

coil
 bar
 pipes in tube
 bag
 carton box
 pallet
 new
 available soon

* on request (delivery time up to 4 weeks) | ** availability by individual arrangements | *** till stock ends

Accessories

O-Ring LBP EPDM Steel/Inox

GROUP: I



Size	Code	*			UM
22	1509182024		20	500	pc.
28	1509182025		20	400	pc.
35	1509182026		20	400	pc.
42	1509182027		20	300	pc.
54	1509182028		20	300	pc.

O-Ring EPDM Steel/Inox

GROUP: I



Size	Code	*			UM
76,1	1609182023		5	100	pc.
88,9	1609182024		5	100	pc.
108	1609182025		5	50	pc.

coil
 bar
 pipes in tube
 bag
 carton box
 pallet
 new
 available soon

* on request (delivery time up to 4 weeks) | ** availability by individual arrangements | *** till stock ends

Tools

REMS pipe cutter

GROUP: K



Range	Code	*		UM
12-54	1948267025		1	pc.
35-108	1948267027		1	pc.

Replacement cutting wheel

GROUP: K



Code	*		UM
1941267037		1	10 pc.

REMS Cento pipe cutting machine

GROUP: K



Range	Code	*		UM
22-108	1948183001		1	pc.

Note:
Cutting wheel included.

coil
 bar
 pipes in tube
 bag
 carton box
 pallet
 new
 available soon

* on request (delivery time up to 4 weeks) | ** availability by individual arrangements | *** till stock ends

REMS stripping tool for pipes

GROUP: K



Range	Code	*		UM
12-54	1948267015		1	pc.

Note:

May be used by hand as well as attached on power drill.

Novopress battery-powered press ACO203XL

GROUP: K



Range	Code	*		UM
22-54	1948267181		1	pc.

Set consists of:

- Battery 18 V/ 5.0 Ah Li-Ion Milwaukee - 2 pcs.
- Charger - 1 pc.
- Grease - 1 pc.
- Plastic case

Novopress EFP203 electric press

GROUP: K



Range	Code	*		UM
12-54	1948267210		1	pc.

Note:

Press tool is offered as a set with plastic case.

coil bar pipes in tube bag carton box pallet new available soon

* on request (delivery time up to 4 weeks) | ** availability by individual arrangements | *** till stock ends

Novopress "M" profile PB2 jaws

GROUP: K



Size	Code	*		UM
22	1948267139		1	pc.
28	1948267141		1	pc.
35	1948267143		1	pc.

Note:

Jaws for EFP203 and ACO203XL press tools.

Novopress "M" profile Snap On collars

GROUP: K



Size	Code	*		UM
42	1948267119		1	pc.
54	1948267121		1	pc.
76,1	1948267145		1	pc.
88,9	1948267044		1	pc.
108	1948267038		1	pc.

Note:

Jaws for diameters 66,7, 76,1 and 88,9 mm should be used with ZB221 adapter for ACO203XL.

Jaw for diameter 66,7 mm must be used with ZB323 adapter for ECO301.

Jaw for diameter 108 mm must be used with ZB221 and ZB222 adapters for ACO203XL.

coil
 bar
 pipes in tube
 bag
 carton box
 pallet
 new
 available soon

* on request (delivery time up to 4 weeks) | ** availability by individual arrangements | *** till stock ends

Novopress HP Snap On collars

GROUP: K



Size	Code	*		UM
35	1948267124		1	pc.
42	1948267126		1	pc.
54	1948267128		1	pc.

Note:

Jaws for diameters 35 - 54 mm with ECO301 press tool must be used with ZB303 adapter.
 Jaws for diameters 35 - 54 mm with ACO203XL press tool must be used with ZB203 adapter.

Novopress adapter ZB221

GROUP: K



Size	Code	*		UM
108	1948267005		1	pc.

Note:

For ACO203XL press tool.
 For diameter 108 mm ZB221 adapter is used for pre-pressing and ZB222 adapter - for final pressing.

Novopress adapter ZB222

GROUP: K



Size	Code	*		UM
108	1948267007		1	pc.

Note:

For ACO203XL press tool.
 For diameter 108 mm ZB221 adapter is used for pre-pressing and ZB222 adapter - for final pressing.

coil bar pipes in tube bag carton box pallet new available soon

* on request (delivery time up to 4 weeks) | ** availability by individual arrangements | *** till stock ends

Novopress battery-powered press ACO403

GROUP: K



Range	Code	*		UM
76,1-108	1948267209		1	pc.

Novopress HP "M" profile collars

GROUP: K



Size	Code	*		UM
76,1	1948267100		1	pc.
88,9	1948267102		1	pc.
108	1948267098		1	pc.

Note:
For ACO401 and ACO403 press tools.

Novopress adapter ZB203

GROUP: K



Range	Code	*		UM
35-54	1948267000		1	pc.

Note:
For EFP203 and ACO203XL press tools.
Steel & Inox: 35-54 mm
Copper: 42-54 mm

coil
 bar
 pipes in tube
 bag
 carton box
 pallet
 new
 available soon

* on request (delivery time up to 4 weeks) | ** availability by individual arrangements | *** till stock ends

Tool set - Novopress ACO103 BT battery-powered press + "M" profile jaws

GROUP: K



Range	Code	*		UM
15-28	1948055008	*	1	set

Set consists of:

- Battery-powered press - 1 pc.
- 1948267093 M15 jaws for press tool - 1 pc.
- 1948267095 M18 jaws for press tool - 1 pc.
- 1942121002 M22 jaws for press tool - 1 pc.
- 1948267097 M28 jaws for press tool - 1 pc.
- 1938267047 Charger - 1 pc.
- 1938267002 Battery 2 Ah - 2 pcs.
- Case

Tool set - KAN-therm Mini battery-powered press + "M" profile jaws

GROUP: K



Range	Code	*		UM
15-28	1936055009		1	pc.

Set consists of:

- 1936055008 - KAN-therm Mini Battery-powered press
- 1936267278 - SBM jaws profile "M" KAN-therm Mini - 15 mm
- 1936267279 - SBM jaws profile "M" KAN-therm Mini - 18 mm
- 1936267280 - SBM jaws profile "M" KAN-therm Mini - 22 mm
- 1936267282 - SBM jaws profile "M" KAN-therm Mini - 28 mm
- 1967267023 - Battery - 2 pcs.
- Charger

coil
 bar
 pipes in tube
 bag
 carton box
 pallet
 new
 available soon

* on request (delivery time up to 4 weeks) | ** availability by individual arrangements | *** till stock ends

REMS Power-Press ACC electric press

GROUP: K



Range	Code	*		UM
12-108	1936267219		1	pc.

Note:
Press tool is offered as a set with case.

REMS Power-Press SE Basic Pack electric press

GROUP: K



Range	Code	*		UM
12-108	1936267160		1	pc.

Note:
Press tool is offered as a set with case.

REMS Akku Press battery-powered press

GROUP: K



Range	Code	*		UM
12-108	1936267152		1	pc.

Note:
Press tool is offered as a set with battery, charger and case. Jaws not included.

coil
 bar
 pipes in tube
 bag
 carton box
 pallet
 new
 available soon

* on request (delivery time up to 4 weeks) | ** availability by individual arrangements | *** till stock ends

REMS "M" profile jaws

GROUP: K



Size	Code	*		UM
22	1948267056		1	pc.
28	1948267061		1	pc.
35	1948267065		1	pc.
42	1948267067		1	pc.
54	1948267069		1	pc.

Note:

Jaws for Power-Press SE, Akku-Press, Power-Press ACC press tools.

Tool set - REMS Power-Press SE electric press + "M" profile jaws

GROUP: K



Range	Code	*		UM
15-35	1948267033		1	set

Set consists of:

- 1936267160 REMS Power-Press SE electric press
- 1948267048 „M" profile jaws 15 mm
- 1948267052 „M" profile jaws 18 mm
- 1948267056 „M" profile jaws 22 mm
- 1948267061 „M" profile jaws 28 mm
- 1948267065 „M" profile jaws 35 mm
- case

 coil
  bar
  pipes in tube
  bag
  carton box
  pallet
  new
  available soon

* on request (delivery time up to 4 weeks) | ** availability by individual arrangements | *** till stock ends

KAN-therm AC ECO electric press

GROUP: K



Range	Code	*		UM
N 12-108	1936267240		1	pc.

Note:
Press tool is offered as a set with case.

KAN-therm AC 3000 electric press

GROUP: K



Range	Code	*		UM
N 12-108	1936267239		1	pc.

Note:
Press tool is offered as a set with case.

KAN-therm DC 4000 battery-powered press

GROUP: K



Range	Code	*		UM
N 12-108	1936267238		1	pc.

Note:
Press tool is offered as a set with battery, charger and case.

coil
 bar
 pipes in tube
 bag
 carton box
 pallet
 N new
 available soon

* on request (delivery time up to 4 weeks) | ** availability by individual arrangements | *** till stock ends

KAN-therm "M" profile jaws

GROUP: K



	Size	Code	*		UM
N	22	1936267251		1	pc.
N	28	1936267252		1	pc.
N	35	1936267253		1	pc.

Note:

Jaws for KAN-therm AC ECO, AC 3000, DC 4000 press tools.

KAN-therm "M" profile 3-segment jaws

GROUP: K



	Size	Code	*		UM
N	42	1936267254		1	pc.
N	54	1936267255		1	pc.

Note:

Jaws for KAN-therm AC ECO, AC 3000, DC 4000 press tools.

coil
 bar
 pipes in tube
 bag
 carton box
 pallet
 N new
 available soon

* on request (delivery time up to 4 weeks) | ** availability by individual arrangements | *** till stock ends

NOTES

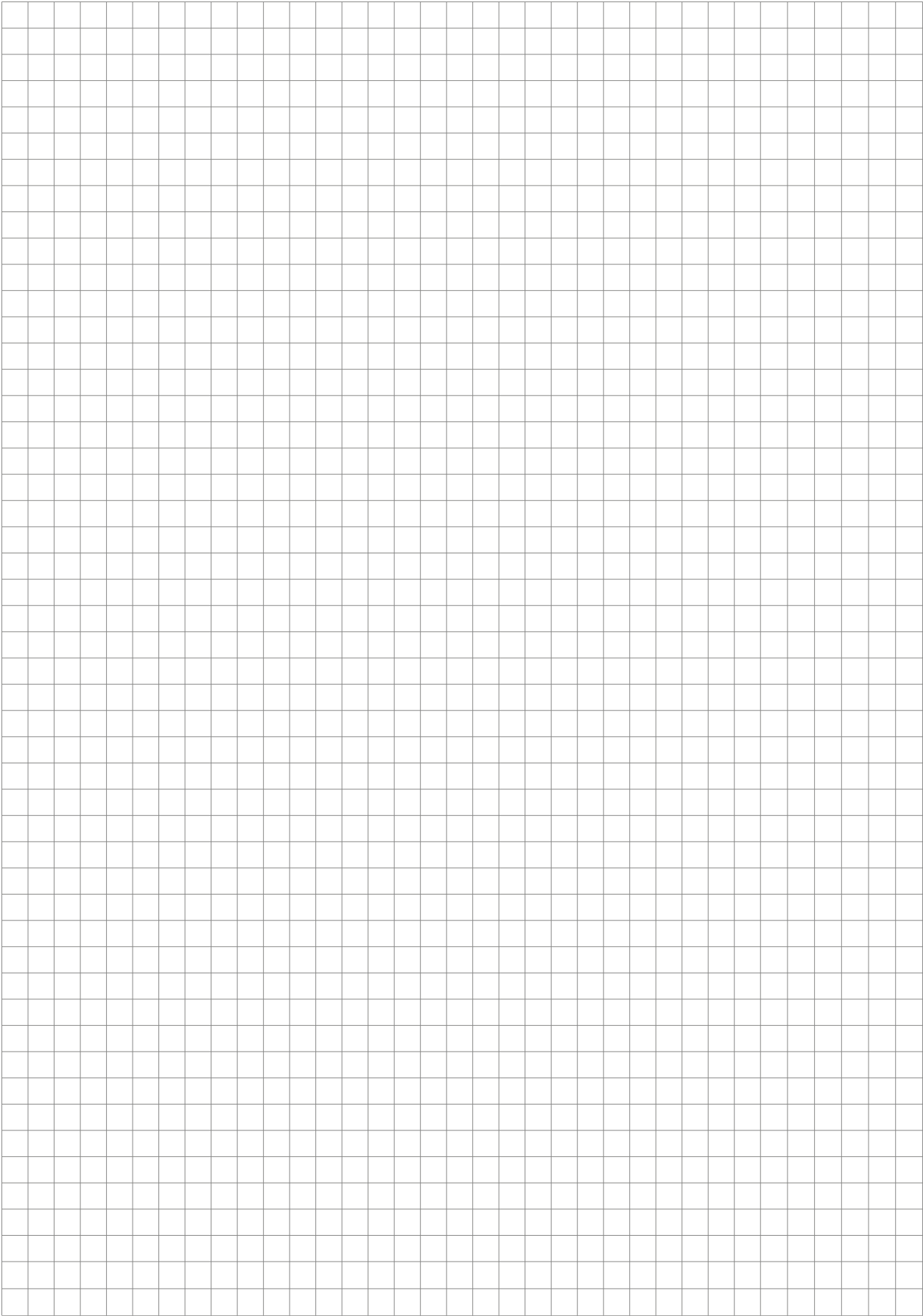

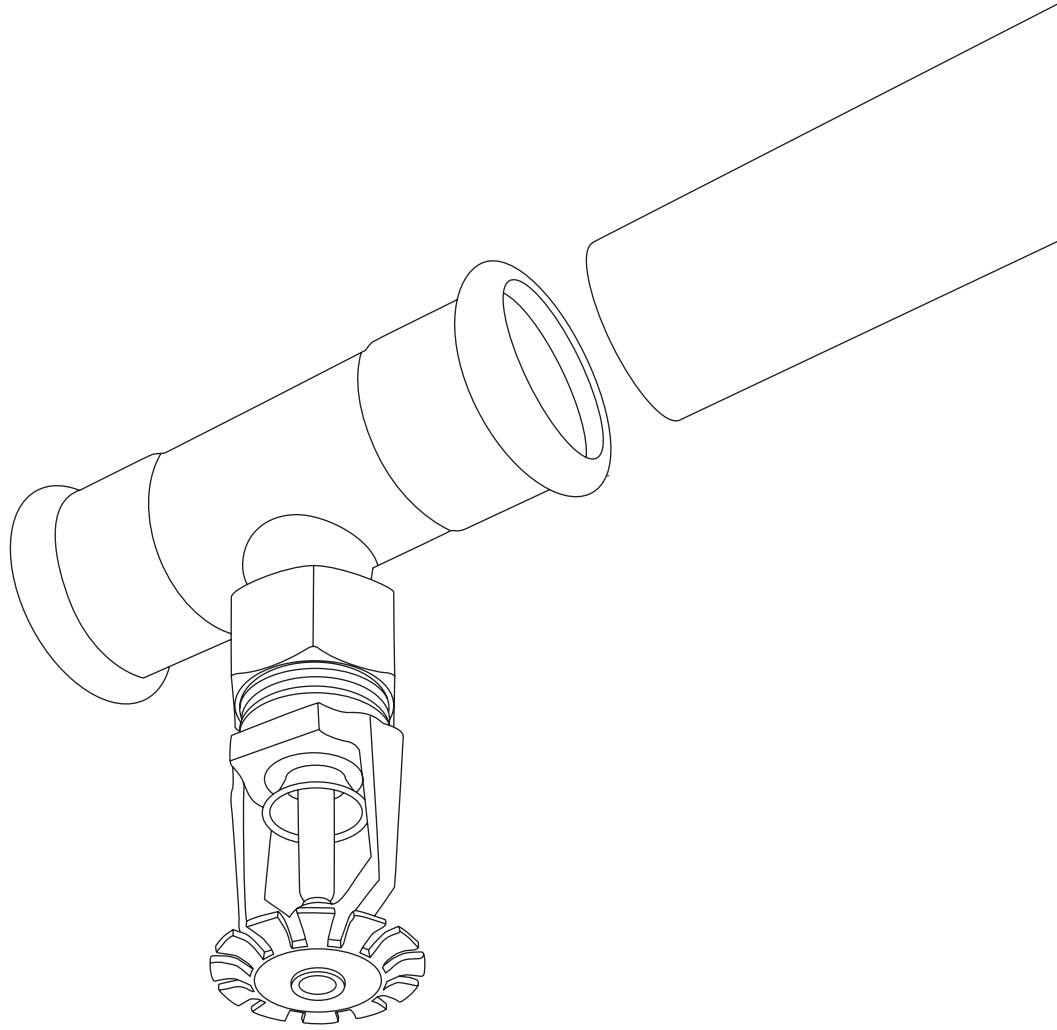

SYSTEM **KAN-therm**

Inox Sprinkler

1 Application and operational conditions

KAN-therm Inox Sprinkler system is designed for constructing pipelines (distributing or pipe branches) of stationary sprinkler systems wet (permanently filled with water) or dry (air) installed in small or medium fire hazard areas (LH, OH1, OH2, OH3 and up to OH4 - in reference to exhibition rooms, theatres and concert halls) (according to VdS CEA 4001 guidelines).

KAN-therm Inox Sprinkler is also suitable for indoor hydrant installations. These installations may be both separate as well as a part of potable water systems.

Application in other fire extinguishing systems is prohibited.

System pipes and fittings hold certificates issued by Fire Protection Scientific Research Centre CNBOP as well as VdS and FM.

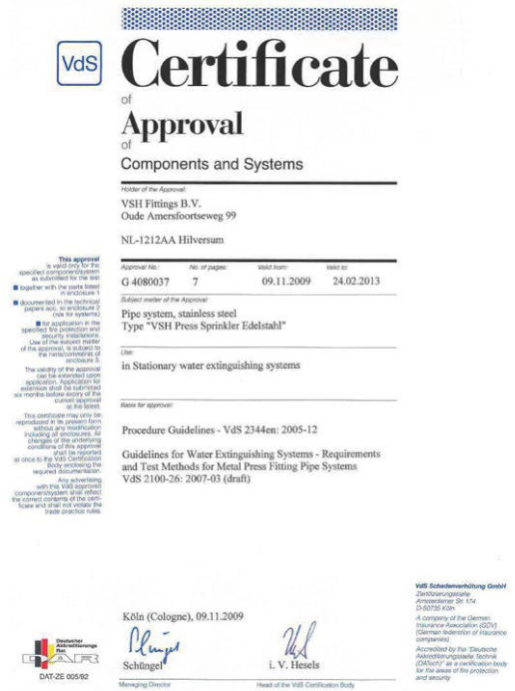

The installation should be designed and constructed according to guidelines included in this document, as well as with applicable standards and regulations.

Designing, assembly and commissioning of the sprinkler system is defined by EN 12845 standard. Stationary fire extinguishing units. Automatic sprinkler units. Design, assembly and maintenance.

Maximum operating pressure of the pipes and fittings is:

- for 22–76,1 mm diameters 16,0 bar,
- for 88,9 mm diameter 12,5 bar,
- for 108 mm diameter 10,0 bar.

2 KAN-therm Inox Sprinkler system - stainless steel pipes



KAN-therm Inox Sprinkler system pipes for sprinkler and hydrant systems are precise X5CrNiMo (1.4401 acc. to EN 10088 AISI 316) stainless steel pipes.

KAN-therm Inox Sprinkler system pipes may be classified as A category incombustible materials, acc. to DIN 4102, part 1.

The pipes are distributed in 6 meters lengths. Minimum pipe bend radius $3,5 \times D$ (for DN20–DN25 diameters).

TAB. 1 PIPE TECHNICAL SPECIFICATION

DN	External diameter × wall thickness	Internal diameter	Unit mass	Water capacity
	mm × mm	[mm]	[kg/m]	[kg/m]
20	22 × 1,5	19,6	0,624	0,302
25	28 × 1,5	25,6	0,790	0,515
32	35 × 1,5	32,0	1,240	0,804
40	42 × 1,5	39,0	1,503	1,195
50	54 × 1,5	51,0	1,972	2,043
65	76,1 × 2,0	72,1	3,550	4,548
80	88,9 × 2,0	84,9	4,150	5,661
100	108 × 2,0	104,0	5,050	8,495

TAB 2. KAN-THERM INOX SPRINKLER PIPES FOR FIRE FIGHTING SYSTEMS

Material	X5CrNiMo stainless steel material no. 1.4401 acc. to EN 10088-2 (AISI 316)
External diameter tolerance	acc. to EN 10305-3
Thermal expansion coefficient	0,0160 mm/m at $\Delta T = 1K$
Minimum bend radius (for diameters up to Ø28 mm)	3,5 × external pipe diameter (up to -10°C)
Delivery	6 m ± 50 mm lengths
Marking	name or manufacturer label, material identification, outside diameter x wall thickness, approval no., manufacture date
Max. operating pressure	16 bar (22-76,1 mm); 12,5 bar (88,9 mm); 10 bar (108 mm)

3 KAN-therm Inox Sprinkler system - pressed stainless steel couplings

KAN-therm Inox Sprinkler System pressed couplings are made of stainless steel, material no. 1.4404 acc. to EN 10088. The couplings are equipped with EPDM rubber sealing ring (O-Ring).

Coupling diameter range DN20–DN100



SYSTEM KAN-therm Inox Sprinkler

Pipes

Stainless steel pipe 1.4401 Sprinkler - bar 6 m

GROUP: H



Size	Code	*			UM
22×1,2	1630194069		6	360	m
28×1,2	1630194070		6	300	m
35×1,5	1630194071		6	180	m
42×1,5	1630194072		6	150	m
54×1,5	1630194073		6	90	m
76,1×2,0	1630194074		6	168	m
88,9×2,0	1630194075		6	138	m
108×2,0	1630194066		6	108	m

 coil  bar  pipes in tube  bag  carton box  pallet  new  available soon

* on request (delivery time up to 4 weeks) | ** availability by individual arrangements | *** till stock ends

Fittings

Male connector

GROUP: G

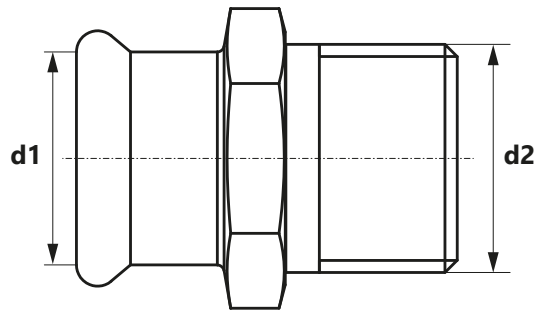

Size (d1 × d2)	Code	*							UM
22 R½"	1611045001		10				70		pc.
22 R¾"	1611045002		10				100		pc.
22 R1"	1611045000		10				60		pc.
28 R¾"	1611045005		10				50		pc.
28 R1"	1611045004		10				60		pc.
28 R1¼"	1611045003		10				30		pc.
35 R1"	1611045007		10				40		pc.
35 R1¼"	1611045008		5				40		pc.
35 R1½"	1611045006		10				20		pc.
42 R1¼"	1611045009		4				12		pc.
42 R1½"	1611045010		4				24		pc.
54 R1½"	1611045011		4				16		pc.
54 R2"	1611045012		4				12		pc.
76,1 R2½"	1611045013		2				20		pc.
88,9 R3"	1611045014		2				20		pc.

Male union connector

GROUP: G

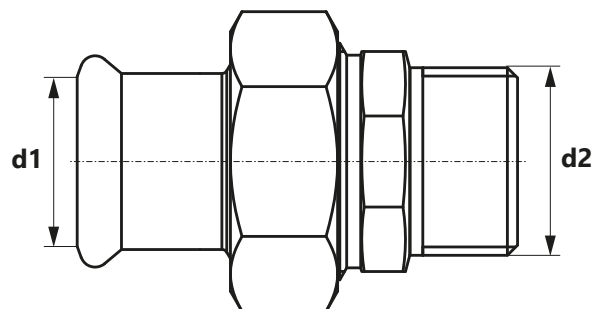

Size (d1 × d2)	Code	*							UM
22 R½"	1611272001		2				40		pc.
22 R¾"	1611272002		2				40		pc.
22 R1"	1611272000		2				30		pc.
28 R1"	1611272003		2				30		pc.
35 R1¼"	1611272004		2				16		pc.
42 R1½"	1611272005		2				12		pc.
54 R2"	1611272006		2				4		pc.

coil
 bar
 pipes in tube
 bag
 carton box
 pallet
 new
 available soon

* on request (delivery time up to 4 weeks) | ** availability by individual arrangements | *** till stock ends

Female connector

GROUP: G

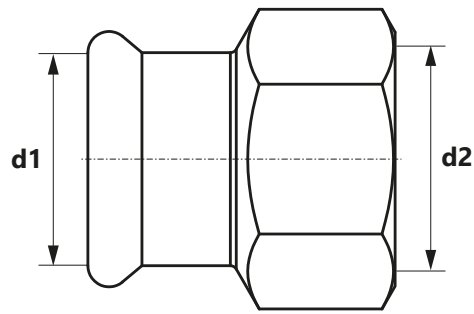

Size (d1 × d2)	Code	*			UM
22 Rp1/2"	1611042001		10	100	pc.
22 Rp3/4"	1611042002		10	100	pc.
22 Rp1"	1611042000		10	60	pc.
28 Rp1/2"	1611042013		10	40	pc.
28 Rp3/4"	1611042005		10	40	pc.
28 Rp1"	1611042003		10	60	pc.
28 Rp1 1/4"	1611042004		10	30	pc.
35 Rp1"	1611042007		10	20	pc.
35 Rp1 1/4"	1611042012		10	30	pc.
35 Rp1 1/2"	1611042006		10	20	pc.
42 Rp1 1/4"	1611042009		4	12	pc.
42 Rp1 1/2"	1611042008		4	24	pc.
54 Rp1 1/2"	1611042010		4	12	pc.
54 Rp2"	1611042011		4	12	pc.

Female union connector

GROUP: G

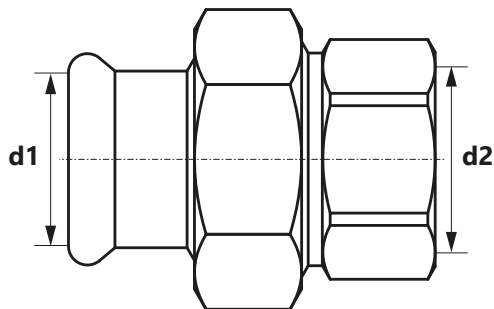

Size (d1 × d2)	Code	*			UM
22 Rp3/4"	1611271001		2	40	pc.
22 Rp1"	1611271000		2	30	pc.
28 Rp1"	1611271002		2	26	pc.
35 Rp1 1/4"	1611271003		1	20	pc.
42 Rp1 1/2"	1611271004		2	8	pc.
54 Rp2"	1611271005		2	4	pc.

coil bar pipes in tube bag carton box pallet new available soon

* on request (delivery time up to 4 weeks) | ** availability by individual arrangements | *** till stock ends

Female half union with flat gasket

GROUP: G

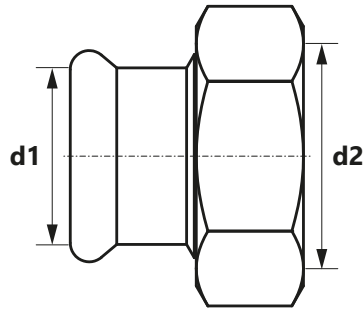

Size (d1×d2)	Code	*			UM
22 Rp1"	1611271006		10	60	pc.
28 Rp1¼"	1611271007		10	40	pc.
35 Rp1½"	1611271008		4	32	pc.
42 Rp1¾"	1611271009		4	12	pc.
54 Rp2⅜"	1611271010		4	8	pc.

Coupling

GROUP: G

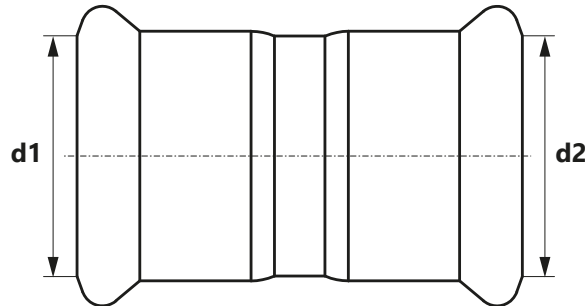

Size (d1=d2)	Code	*			UM
22	1611245001		10	80	pc.
28	1611245002		10	60	pc.
35	1611245003		5	40	pc.
42	1611245004		4	24	pc.
54	1611245005		4	16	pc.
76,1	1611245006		4	24	pc.
88,9	1611245007		4	8	pc.
108	1611245000		2	10	pc.

coil
 bar
 pipes in tube
 bag
 carton box
 pallet
 new
 available soon

* on request (delivery time up to 4 weeks) | ** availability by individual arrangements | *** till stock ends

Slip coupling

GROUP: G

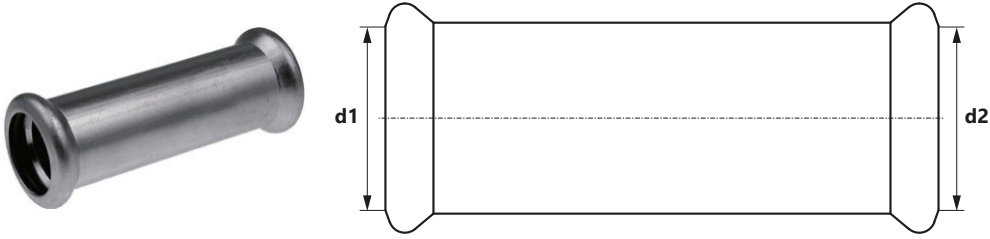

Size (d1=d2)	Code	*			UM
22	1611080001		10	60	pc.
28	1611080002		10	40	pc.
35	1611080003		5	20	pc.
42	1611080004		4	16	pc.
54	1611080005		2	8	pc.
76,1	1611080006		-	2	pc.
88,9	1611080007		-	2	pc.
108	1611080000		-	2	pc.

Elbow 90°

GROUP: G

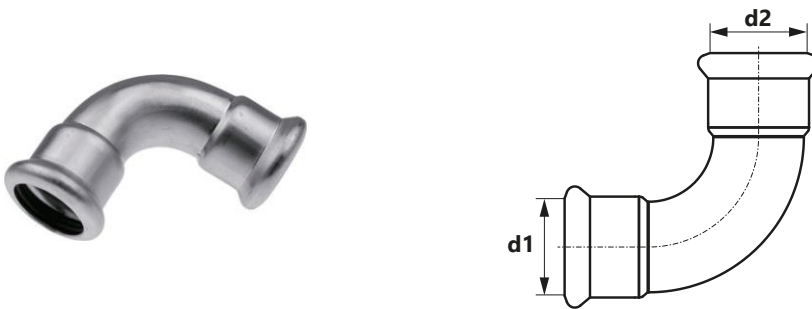

Size (d1=d2)	Code	*			UM
22	1611068026		10	60	pc.
28	1611068027		5	30	pc.
35	1611068028		5	20	pc.
42	1611068029		2	8	pc.
54	1611068030		2	8	pc.
76,1	1611068031		2	12	pc.
88,9	1611068032		2	8	pc.
108	1611068025		2	4	pc.

coil
 bar
 pipes in tube
 bag
 carton box
 pallet
 new
 available soon

* on request (delivery time up to 4 weeks) | ** availability by individual arrangements | *** till stock ends

Nipple elbow 90°

GROUP: G

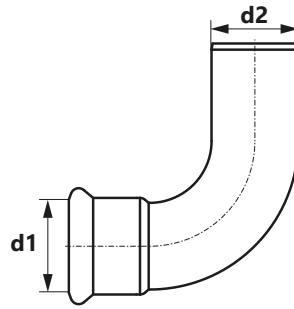

Size (d1=d2)	Code	*			UM
22	1611068034		5	60	pc.
28	1611068035		5	30	pc.
35	1611068036		5	10	pc.
42	1611068037		2	8	pc.
54	1611068038		2	6	pc.
76,1	1611068039		2	10	pc.
88,9	1611068040		2	8	pc.
108	1611068033		2	1	pc.

Elbow 45°

GROUP: G

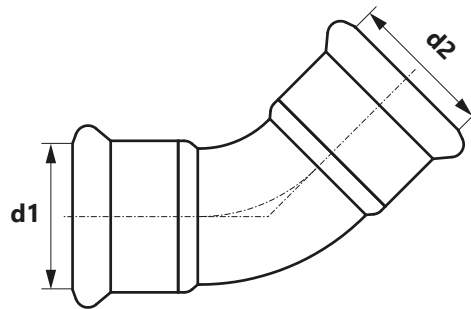

Size (d1=d2)	Code	*			UM
22	1611068010		10	70	pc.
28	1611068011		10	40	pc.
35	1611068012		5	25	pc.
42	1611068013		2	16	pc.
54	1611068014		2	8	pc.
76,1	1611068015		2	8	pc.
88,9	1611068016		-	2	pc.
108	1611068009		-	2	pc.

coil
 bar
 pipes in tube
 bag
 carton box
 pallet
 new
 available soon

* on request (delivery time up to 4 weeks) | ** availability by individual arrangements | *** till stock ends

Nipple elbow 45°

GROUP: G

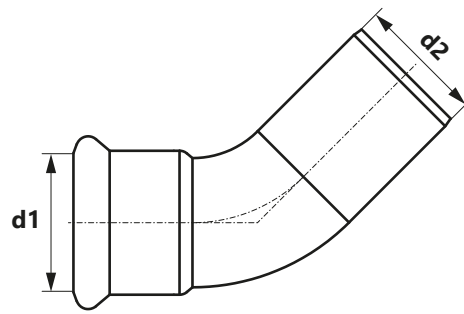

Size (d1=d2)	Code	*			UM
22	1611068018		10	60	pc.
28	1611068019		10	40	pc.
35	1611068020		5	25	pc.
42	1611068021		4	16	pc.
54	1611068022		2	8	pc.
76,1	1611068023		2	16	pc.
88,9	1611068024		2	8	pc.
108	1611068017		2	4	pc.

Tee

GROUP: G

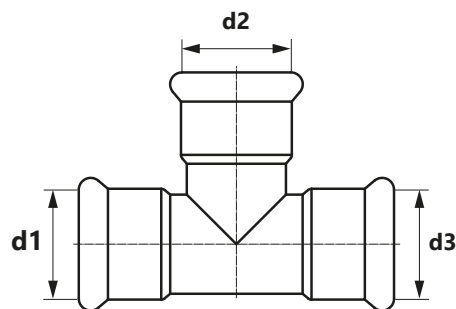

Size (d1=d2=d3)	Code	*			UM
22	1611257001		10	40	pc.
28	1611257002		5	25	pc.
35	1611257003		5	15	pc.
42	1611257004		4	8	pc.
54	1611257005		2	6	pc.
76,1	1611257006		2	6	pc.
88,9	1611257007		2	6	pc.
108	1611257000		-	2	pc.



coil
 bar
 pipes in tube
 bag
 carton box
 pallet
 new
 available soon

* on request (delivery time up to 4 weeks) | ** availability by individual arrangements | *** till stock ends

Reducing tee

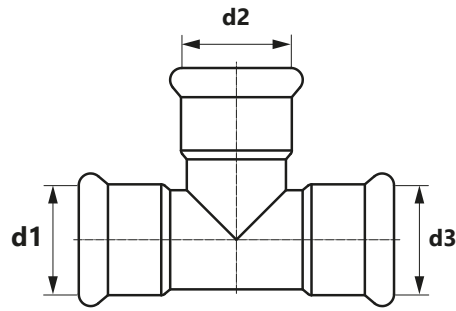
GROUP: G



Size (d1/d2/d3)	Code	*			UM
28 / 22 / 28	1611260007		5	30	pc.
35 / 22 / 35	1611260008		5	20	pc.
35 / 28 / 35	1611260009		5	20	pc.
42 / 22 / 42	1611260010		4	12	pc.
42 / 28 / 42	1611260011		4	12	pc.
42 / 35 / 42	1611260012		4	12	pc.
54 / 22 / 54	1611260013		2	8	pc.
54 / 28 / 54	1611260014		2	8	pc.
54 / 35 / 54	1611260015		2	8	pc.
54 / 42 / 54	1611260016		2	8	pc.
76,1 / 22 / 76,1	1611260017		-	2	pc.
76,1 / 28 / 76,1	1611260018		-	2	pc.
76,1 / 35 / 76,1	1611260019		-	10	pc.
76,1 / 42 / 76,1	1611260020		-	2	pc.
76,1 / 54 / 76,1	1611260021		-	2	pc.
88,9 / 22 / 88,9	1611260022		-	2	pc.
88,9 / 28 / 88,9	1611260023		-	2	pc.
88,9 / 35 / 88,9	1611260024		-	2	pc.
88,9 / 42 / 88,9	1611260025		-	2	pc.
88,9 / 54 / 88,9	1611260026		-	8	pc.
88,9 / 76,1 / 88,9	1611260027		-	2	pc.
108 / 22 / 108	1611260000		-	6	pc.
108 / 28 / 108	1611260001		-	2	pc.
108 / 35 / 108	1611260002		-	4	pc.
108 / 42 / 108	1611260003		-	2	pc.
108 / 54 / 108	1611260004		-	2	pc.
108 / 76,1 / 108	1611260005		-	2	pc.
108 / 88,9 / 108	1611260006		-	2	pc.

 coil
  bar
  pipes in tube
  bag
  carton box
  pallet
  new
  available soon

* on request (delivery time up to 4 weeks) | ** availability by individual arrangements | *** till stock ends

Nipple reducer

GROUP: G

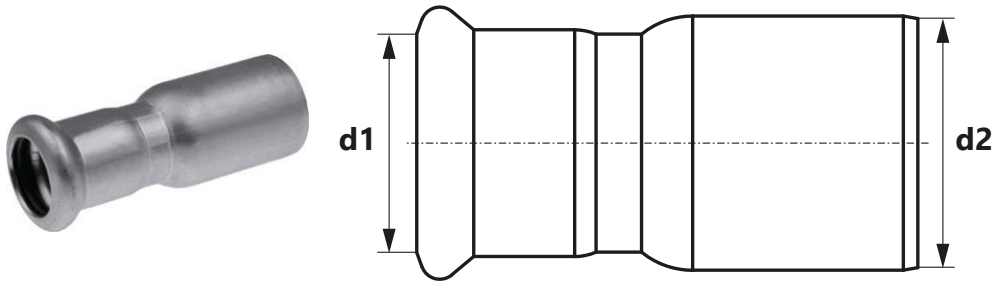

Size (d1/d2)	Code	*			UM
28 / 22	1611220003		10	80	pc.
35 / 22	1611220004		5	50	pc.
35 / 28	1611220005		5	60	pc.
42 / 22	1611220006		4	24	pc.
42 / 28	1611220007		4	24	pc.
42 / 35	1611220008		4	24	pc.
54 / 22	1611220009		4	16	pc.
54 / 28	1611220010		4	16	pc.
54 / 35	1611220011		4	16	pc.
54 / 42	1611220012		4	16	pc.
76,1 / 42	1611220013		-	4	pc.
76,1 / 54	1611220014		4	32	pc.
88,9 / 54	1611220015		-	4	pc.
88,9 / 76,1	1611220016		-	4	pc.
108 / 54	1611220000		-	2	pc.
108 / 76,1	1611220001		-	2	pc.
108 / 88,9	1611220002		2	10	pc.

Male elbow 90°

GROUP: G

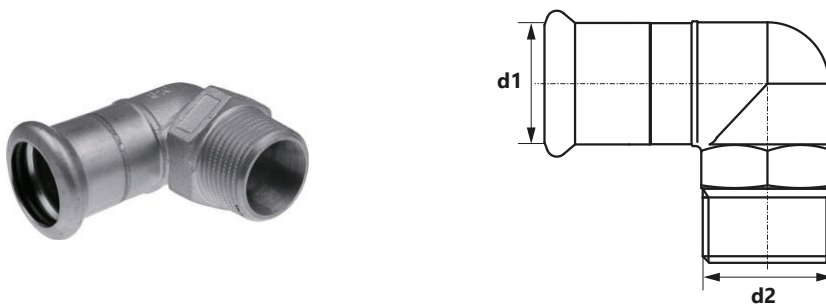

Size (d1 × d2)	Code	*			UM
22 R $\frac{3}{4}$ "	1611070000		10	60	pc.
28 R1"	1611070001		10	30	pc.
35 R1 $\frac{1}{4}$ "	1611070002		5	20	pc.
42 R1 $\frac{1}{2}$ "	1611070003		2	16	pc.
54 R2"	1611070004		2	8	pc.

coil
 bar
 pipes in tube
 bag
 carton box
 pallet
 new
 available soon

* on request (delivery time up to 4 weeks) | ** availability by individual arrangements | *** till stock ends

Female elbow 90°

GROUP: G

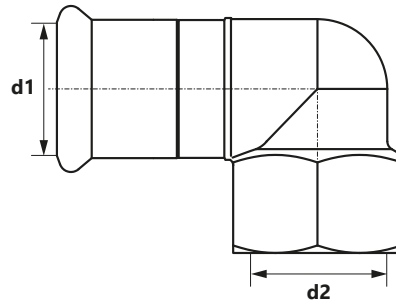

Size (d1 × d2)	Code	*			UM
22 R1/2"	1611068001		10	50	pc.
22 Rp3/4"	1611068000		10	50	pc.
28 R1/2"	1611068006		5	30	pc.
28 Rp3/4"	1611068003		5	30	pc.
28 R1"	1611068002		10	30	pc.
35 Rp1/2"	1611068008		5	10	pc.
35 Rp3/4"	1611068005		5	10	pc.
35 R1"	1611068007		5	10	pc.
35 R1 1/4"	1611068004		5	10	pc.

 coil
  bar
  pipes in tube
  bag
  carton box
  pallet
  new
  available soon

* on request (delivery time up to 4 weeks) | ** availability by individual arrangements | *** till stock ends

Female tee

GROUP: G

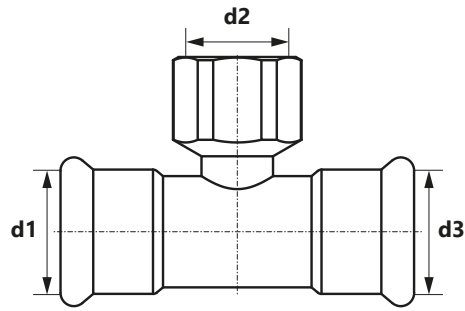

Size (d1 = d3 × d2)	Code	*			UM
22 Rp½"	1611257010		10	40	pc.
22 Rp¾"	1611257011		10	40	pc.
28 Rp½"	1611257012		5	30	pc.
28 Rp¾"	1611257014		10	30	pc.
28 Rp1"	1611257013		5	30	pc.
35 Rp½"	1611257015		5	20	pc.
35 Rp¾"	1611257017		5	20	pc.
35 Rp1"	1611257016		5	20	pc.
42 Rp½"	1611257018		4	16	pc.
42 Rp¾"	1611257020		4	12	pc.
42 Rp1"	1611257019		4	12	pc.
54 Rp½"	1611257021		2	8	pc.
54 Rp¾"	1611257023		2	8	pc.
54 Rp1"	1611257022		2	8	pc.
54 Rp2"	1611257024		2	6	pc.
76,1 Rp¾"	1611257026		2	12	pc.
76,1 Rp2"	1611257025		-	2	pc.
88,9 Rp¾"	1611257028		-	2	pc.
88,9 Rp2"	1611257027		-	2	pc.
108 Rp¾"	1611257009		-	2	pc.
108 Rp2"	1611257008		-	2	pc.

Female directly fixed wallplate elbow

GROUP: G

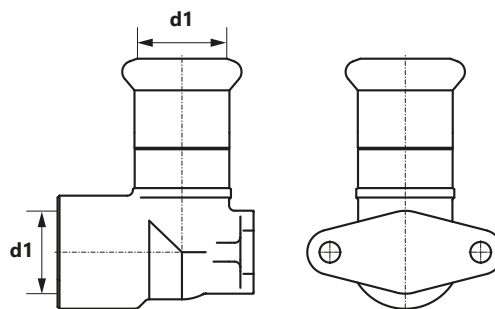

Size (d1 × d2 × l)	Code	*			UM
22 Rp¾" L = 64 mm	1611285001		10	40	pc.
22 Rp¾" L = 52 mm	1611285000		10	50	pc.

coil
 bar
 pipes in tube
 bag
 carton box
 pallet
 new
 available soon

* on request (delivery time up to 4 weeks) | ** availability by individual arrangements | *** till stock ends

Stop end

GROUP: G

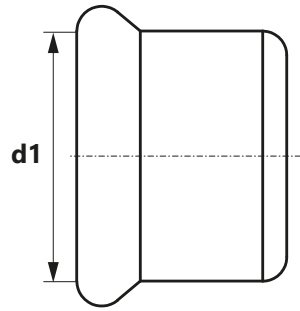

Size (d1)	Code	*			UM
22	1611250001		10	150	pc.
28	1611250002		10	130	pc.
35	1611250003		5	75	pc.
42	1611250004		4	48	pc.
54	1611250005		4	24	pc.
76,1	1611250006		2	4	pc.
88,9	1611250007		2	4	pc.
108	1611250000		2	4	pc.

Crossover

GROUP: G

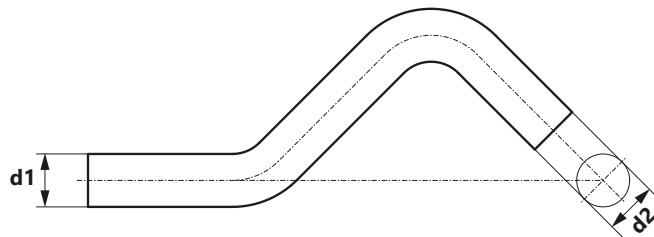

Size (d1=d2)	Code	*			UM
22	1611022000		10	50	pc.
28	1611022001		10	20	pc.

coil
 bar
 pipes in tube
 bag
 carton box
 pallet
 new
 available soon

* on request (delivery time up to 4 weeks) | ** availability by individual arrangements | *** till stock ends

Bend 15°

GROUP: G



Size (d1=d2)	Code	*			UM
28	1611011000		10	40	pc.
35	1611011001		5	15	pc.
42	1611011002		2	20	pc.
54	1611011003		2	10	pc.

Bend 30°

GROUP: G

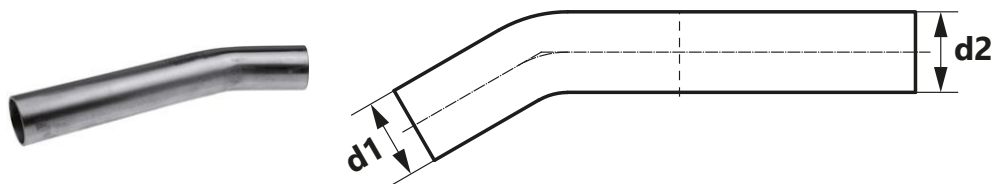

Size (d1=d2)	Code	*			UM
28	1611011004		10	40	pc.
35	1611011005		4	12	pc.
42	1611011006		2	20	pc.
54	1611011007		2	8	pc.

coil
 bar
 pipes in tube
 bag
 carton box
 pallet
 new
 available soon

* on request (delivery time up to 4 weeks) | ** availability by individual arrangements | *** till stock ends

Bend 60°

GROUP: G

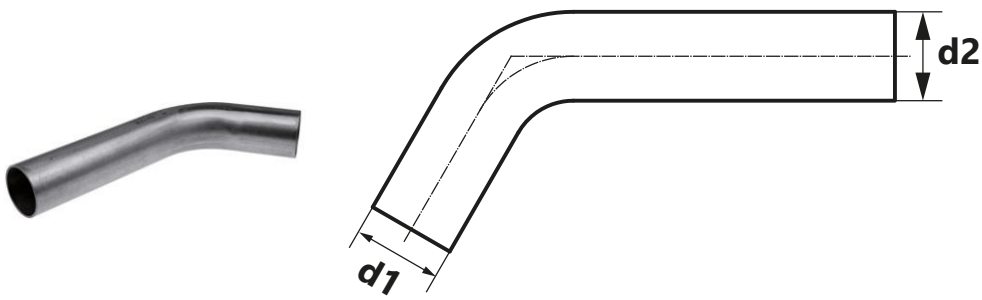

Size (d1=d2)	Code	*			UM
28	1611011008		5	30	pc.
35	1611011009		4	12	pc.
42	1611011010		-	5	pc.
54	1611011011		2	6	pc.

Bend 90°

GROUP: G

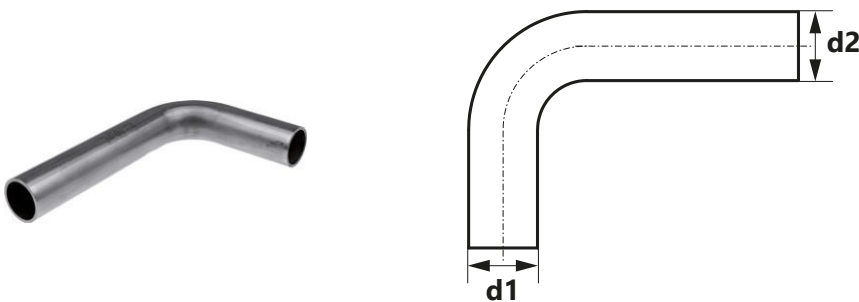

Size (d1=d2)	Code	*			UM
22	1611011012		10	30	pc.
28	1611011013		5	20	pc.
35	1611011014		4	8	pc.
42	1611011015		2	4	pc.
54	1611011016		-	2	pc.

coil
 bar
 pipes in tube
 bag
 carton box
 pallet
 new
 available soon

* on request (delivery time up to 4 weeks) | ** availability by individual arrangements | *** till stock ends

Flange PN16

GROUP: G

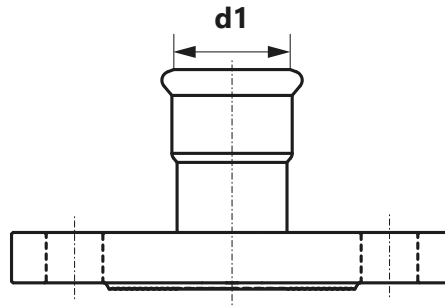

Size (d1)	Code	*			UM
22 DN20	1611091004		1	12	pc.
28 DN25	1611091005		1	12	pc.
35 DN32	1611091001		1	6	pc.
42 DN40	1611091006		1	4	pc.
54 DN50	1611091007		1	2	pc.
76,1 DN65	1611091002		1	4	pc.
88,9 DN80	1611091003		1	2	pc.
108 DN100	1611091000		1	2	pc.

Flange connector

GROUP: G

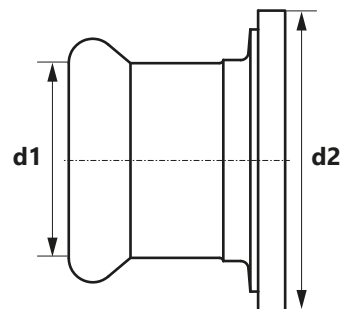

Size (d1 × d2)	Code	*			UM
22 R1¼"	1611090001		20	80	pc.
22 R1½"	1611090000		20	80	pc.
28 R1½"	1611090002		20	80	pc.
35 R2"	1611090003		10	30	pc.
42 R2¼"	1611090004		10	30	pc.
54 R2¾"	1611090005		5	20	pc.

coil
 bar
 pipes in tube
 bag
 carton box
 pallet
 new
 available soon

* on request (delivery time up to 4 weeks) | ** availability by individual arrangements | *** till stock ends

Coupling Inox Sprinkler/Groove

GROUP: G

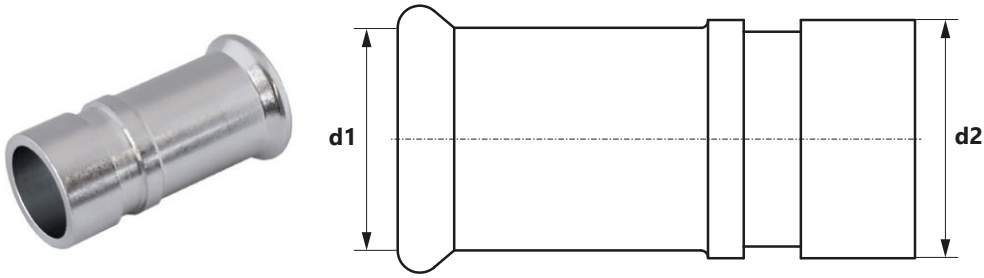

Size (d1 × d2)	Code	*			UM
28 / 33,7	1611042014		10	30	pc.
35 / 42,4	1611042015		10	30	pc.
42 / 48,3	1611042016		5	20	pc.
54 / 60,3	1611042017		5	15	pc.
76,1	1611042019		2	30	pc.
88,9	1609042036		2	30	pc.
108 / 114	1609042029		2	30	pc.

Female slip connector

GROUP: G

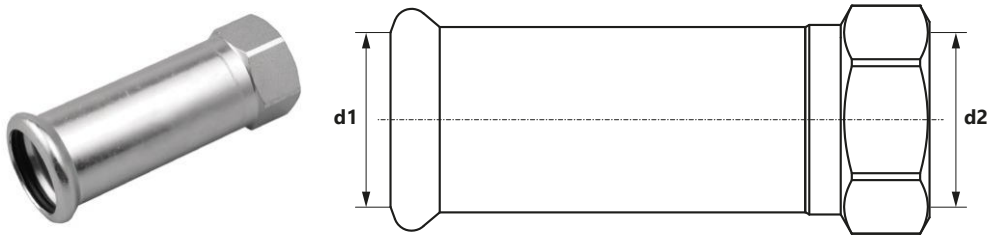

Size (d1 × d2)	Code	*			UM
22 Rp½"	1611042020		10	60	pc.
22 Rp¾"	1611042021		10	60	pc.
28 Rp½"	1611042022		10	40	pc.
28 Rp¾"	1611042023		10	40	pc.

coil
 bar
 pipes in tube
 bag
 carton box
 pallet
 new
 available soon

* on request (delivery time up to 4 weeks) | ** availability by individual arrangements | *** till stock ends

Flexible hose with straight ending

GROUP: G

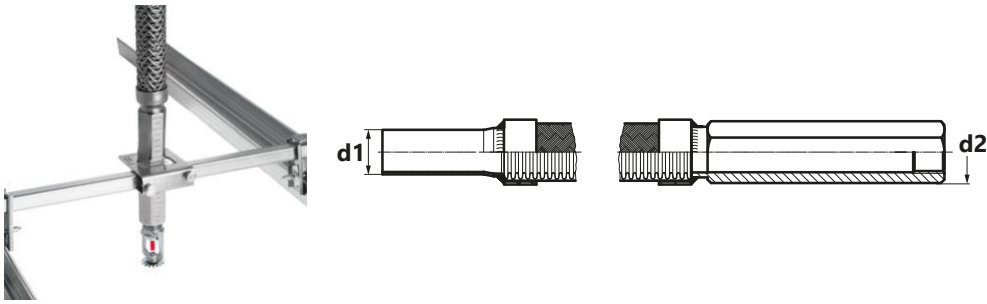

Size (d1 × d2 × l)	Code	*			UM
22 Rp½" 1000 mm	1611289001	-	-	10	pc.
22 Rp½" 1500 mm	1511289005	-	-	10	pc.
22 Rp½" 2000 mm	1511289006	-	-	10	pc.
28 Rp½" 1000 mm	1511289007	-	-	10	pc.
28 Rp½" 1500 mm	1511289008	-	-	10	pc.
28 Rp½" 2000 mm	1511289009	-	-	10	pc.

Flexible hose with angle ending

GROUP: G

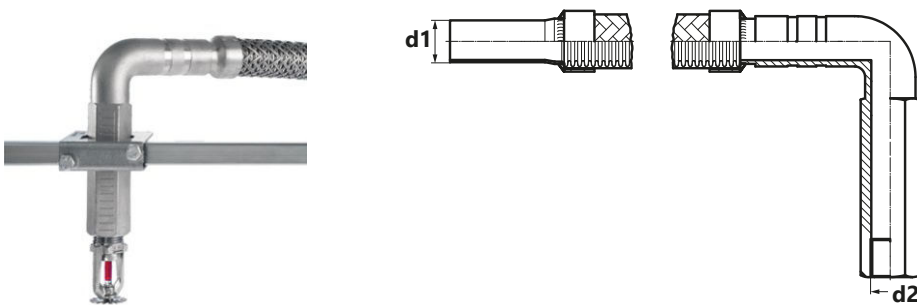

Size (d1 × d2 × l)	Code	*			UM
22 Rp½" 800 mm	1511289000	-	-	10	pc.
22 Rp½" 1000 mm	1611289000	-	-	10	pc.
28 Rp½" 800 mm	1511289002	-	-	10	pc.
28 Rp½" 1500 mm	1511289004	-	-	10	pc.

coil
 bar
 pipes in tube
 bag
 carton box
 pallet
 new
 available soon

* on request (delivery time up to 4 weeks) | ** availability by individual arrangements | *** till stock ends

Accessories

O-Ring LBP EPDM Steel/Inox

GROUP: I



Size	Code	*			UM
22	1509182024		20	500	pc.
28	1509182025		20	400	pc.
35	1509182026		20	400	pc.
42	1509182027		20	300	pc.
54	1509182028		20	300	pc.

O-Ring EPDM Steel/Inox

GROUP: I



Size	Code	*			UM
76,1	1609182023		5	100	pc.
88,9	1609182024		5	100	pc.
108	1609182025		5	50	pc.

coil
 bar
 pipes in tube
 bag
 carton box
 pallet
 new
 available soon

* on request (delivery time up to 4 weeks) | ** availability by individual arrangements | *** till stock ends

Tools

REMS pipe cutter

GROUP: K



Range	Code	*		UM
12-54	1948267025		1	pc.
35-108	1948267027		1	pc.

Replacement cutting wheel

GROUP: K



Code	*		UM
1941267037		1	10 pc.

REMS Cento pipe cutting machine

GROUP: K



Range	Code	*		UM
22-108	1948183001		1	pc.

Note:
Cutting wheel included.

coil
 bar
 pipes in tube
 bag
 carton box
 pallet
 new
 available soon

* on request (delivery time up to 4 weeks) | ** availability by individual arrangements | *** till stock ends

REMS stripping tool for pipes

GROUP: K



Range	Code	*		UM
12-54	1948267015		1	pc.

Note:
May be used by hand as well as attached on power drill.

Novopress battery-powered press ACO203XL

GROUP: K



Range	Code	*		UM
22-54	1948267181		1	pc.

Set consists of:
 ■ Battery 18 V/ 5.0 Ah Li-Ion Milwaukee - 2 pcs.
 ■ Charger - 1 pc.
 ■ Grease - 1 pc.
 ■ Plastic case

Novopress EFP203 electric press

GROUP: K



Range	Code	*		UM
12-54	1948267210		1	pc.

Note:
Press tool is offered as a set with plastic case.

coil bar pipes in tube bag carton box pallet new available soon

* on request (delivery time up to 4 weeks) | ** availability by individual arrangements | *** till stock ends

Novopress "M" profile PB2 jaws

GROUP: K



Size	Code	*		UM
22	1948267139		1	pc.
35	1948267143		1	pc.
28	1948267141		1	pc.

Note:

Jaws for EFP203 and ACO203XL press tools.

Novopress "M" profile Snap On collars

GROUP: K



Size	Code	*		UM
42	1948267119		1	pc.
54	1948267121		1	pc.
76,1	1948267145		1	pc.
88,9	1948267044		1	pc.
108	1948267038		1	pc.

Note:

Jaws for diameters 66,7, 76,1 and 88,9 mm should be used with ZB221 adapter for ACO203XL.

Jaw for diameter 66,7 mm must be used with ZB323 adapter for ECO301.

Jaw for diameter 108 mm must be used with ZB221 and ZB222 adapters for ACO203XL.

coil
 bar
 pipes in tube
 bag
 carton box
 pallet
 new
 available soon

* on request (delivery time up to 4 weeks) | ** availability by individual arrangements | *** till stock ends

Novopress HP Snap On collars

GROUP: K



Size	Code	*		UM
35	1948267124		1	pc.
42	1948267126		1	pc.
54	1948267128		1	pc.

Note:
 Jaws for diameters 35 - 54 mm with ECO301 press tool must be used with ZB303 adapter.
 Jaws for diameters 35 - 54 mm with ACO203XL press tool must be used with ZB203 adapter.

Adapter Novopress ZB221

GROUP: K



Size	Code	*		UM
108	1948267005		1	pc.

Note:
 For ACO203XL press tool.
 For diameter 108 mm ZB221 adapter is used for pre-pressing and ZB222 adapter - for final pressing.

Adapter Novopress ZB222

GROUP: K



Size	Code	*		UM
108	1948267007		1	pc.

Note:
 For ACO203XL press tool.
 For diameter 108 mm ZB221 adapter is used for pre-pressing and ZB222 adapter - for final pressing.

coil
 bar
 pipes in tube
 bag
 carton box
 pallet
 new
 available soon

* on request (delivery time up to 4 weeks) | ** availability by individual arrangements | *** till stock ends

Novopress battery-powered press ACO403

GROUP: K



Range	Code	*		UM
76,1-108	1948267209		1	pc.

Novopress HP "M" profile collars

GROUP: K



Size	Code	*		UM
76,1	1948267100		1	pc.
88,9	1948267102		1	pc.
108	1948267098		1	pc.

Note:
Collars for ACO401 and ACO403 press tools.

Novopress adapter ZB203

GROUP: K



Range	Code	*		UM
35-54	1948267000		1	pc.

Note:
For EFP203 and ACO203XL press tools.
Steel & Inox: 35-54 mm
Copper: 42-54 mm

 coil  bar  pipes in tube  bag  carton box  pallet  new  available soon

* on request (delivery time up to 4 weeks) | ** availability by individual arrangements | *** till stock ends

Tool set - Novopress ACO103 BT battery-powered press + "M" profile jaws

GROUP: K



Range	Code	*		UM
15-28	1948055008	*	1	set

Set consists of:

- Battery-powered press - 1 pc.
- 1948267093 M15 jaws for press tool - 1 pc.
- 1948267095 M18 jaws for press tool - 1 pc.
- 1942121002 M22 jaws for press tool - 1 pc.
- 1948267097 M28 jaws for press tool - 1 pc.
- 1938267047 Charger - 1 pc.
- 1938267002 Battery 2 Ah - 2 pcs.
- Case

Tool set - KAN-therm Mini battery-powered press + "M" profile jaws

GROUP: K



Range	Code	*		UM
15-28	1936055009		1	pc.

Set consists of:

- 1936055008 - KAN-therm Mini Battery-powered press
- 1936267278 - SBM jaws profile "M" KAN-therm Mini - 15 mm
- 1936267279 - SBM jaws profile "M" KAN-therm Mini - 18 mm
- 1936267280 - SBM jaws profile "M" KAN-therm Mini - 22 mm
- 1936267282 - SBM jaws profile "M" KAN-therm Mini - 28 mm
- 1967267023 - Battery - 2 pcs.
- Charger

coil
 bar
 pipes in tube
 bag
 carton box
 pallet
 new
 available soon

* on request (delivery time up to 4 weeks) | ** availability by individual arrangements | *** till stock ends

REMS Power-Press ACC electric press

GROUP: K



Range	Code	*		UM
12-108	1936267219		1	pc.

Note:
Press tool is offered as a set with case.

REMS Power-Press SE Basic Pack electric press

GROUP: K



Range	Code	*		UM
12-108	1936267160		1	pc.

Note:
Press tool is offered as a set with case.

REMS Akku Press battery-powered press

GROUP: K



Range	Code	*		UM
12-108	1936267152		1	pc.

Note:
Press tool is offered as a set with battery, charger and case. Jaws not included.

coil
 bar
 pipes in tube
 bag
 carton box
 pallet
 new
 available soon

* on request (delivery time up to 4 weeks) | ** availability by individual arrangements | *** till stock ends

REMS "M" profile jaws

GROUP: K



Size	Code	*		UM
22	1948267056		1	pc.
28	1948267061		1	pc.
35	1948267065		1	pc.
42	1948267067		1	pc.
54	1948267069		1	pc.

Note:

Jaws for Power-Press SE, Akku-Press, Power-Press ACC press tools.

Tool set - REMS Power-Press SE electric press + "M" profile jaws

GROUP: K



Range	Code	*		UM
15-35	1948267033		1	set

Set consists of:

- 1936267160 REMS Power-Press SE electric press
- 1948267048 „M" profile jaws 15 mm
- 1948267052 „M" profile jaws 18 mm
- 1948267056 „M" profile jaws 22 mm
- 1948267061 „M" profile jaws 28 mm
- 1948267065 „M" profile jaws 35 mm
- case

 coil
  bar
  pipes in tube
  bag
  carton box
  pallet
  new
  available soon

* on request (delivery time up to 4 weeks) | ** availability by individual arrangements | *** till stock ends

KAN-therm AC ECO electric press

GROUP: K



Range	Code	*		UM
N 12-108	1936267240		1	pc.

Note:
Press tool is offered as a set with case.

KAN-therm AC 3000 electric press

GROUP: K



Range	Code	*		UM
N 12-108	1936267239		1	pc.

Note:
Press tool is offered as a set with case.

KAN-therm DC 4000 battery-powered press

GROUP: K



Range	Code	*		UM
N 12-108	1936267238		1	pc.

Note:
Press tool is offered as a set with battery, charger and case.

coil
 bar
 pipes in tube
 bag
 carton box
 pallet
 N new
 available soon

* on request (delivery time up to 4 weeks) | ** availability by individual arrangements | *** till stock ends

KAN-therm "M" profile jaws

GROUP: K



	Size	Code	*		UM
N	22	1936267251		1	pc.
N	28	1936267252		1	pc.
N	35	1936267253		1	pc.

Note:

Jaws for KAN-therm AC ECO, AC 3000, DC 4000 press tools.

KAN-therm "M" profile 3-segment jaws

GROUP: K



	Size	Code	*		UM
N	42	1936267254		1	pc.
N	54	1936267255		1	pc.

Note:

Jaws for KAN-therm AC ECO, AC 3000, DC 4000 press tools.

coil
 bar
 pipes in tube
 bag
 carton box
 pallet
 N new
 available soon

* on request (delivery time up to 4 weeks) | ** availability by individual arrangements | *** till stock ends

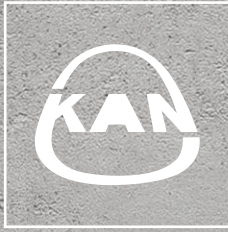

Install your **future**

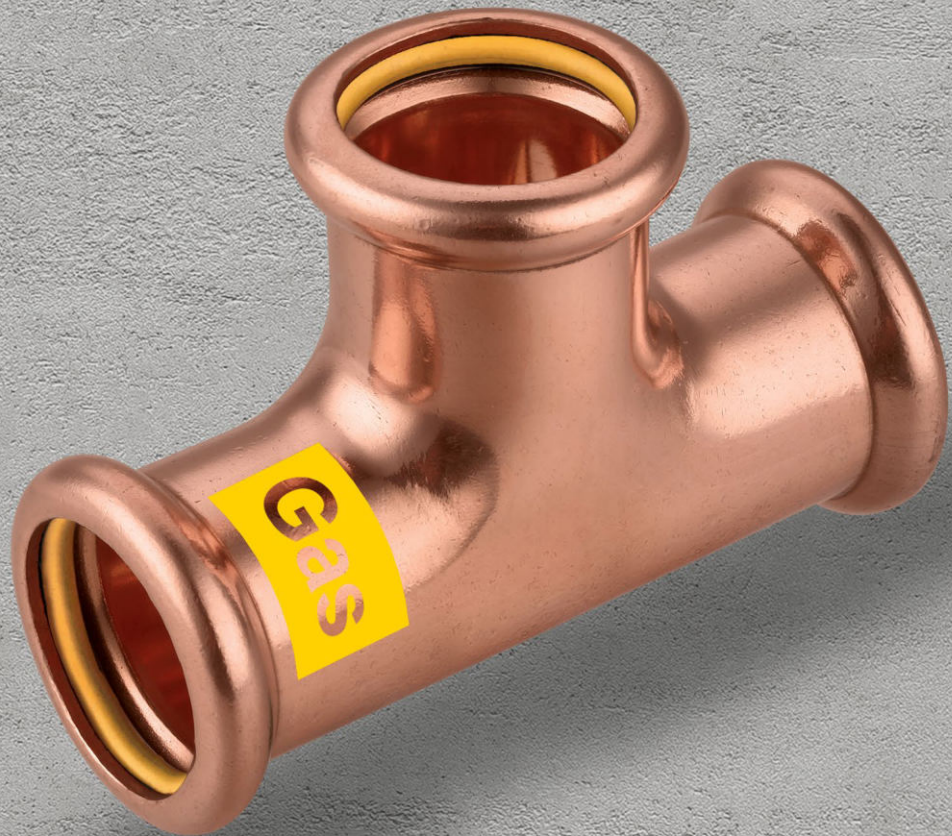

SYSTEM **KAN-therm**

Copper Gas

Modern approach
to classic solutions

EN 22/09

Ø 15-54 mm

Table of contents

SYSTEM **KAN-therm** Copper Gas

1	Modern connection technology	93
2	Durable connection technology	94
2.1	Applicability	94
2.2	Advantages	94
3	Assembly of connections	95
4	Tools	99
4.1	Tools – Safety	101
5	Detailed information	101
6	Data on elongation and thermal conductivity	102
7	Recommendations for use	102
8	Threaded connections, connection to other KAN-therm systems	103
9	Pipeline assembly	104
9.1	Fixed (PS) and slidable (PP) points	104
9.2	Elongation compensation	105



SYSTEM **KAN-therm** Copper Gas

KAN-therm Copper is a system of fittings made of high quality copper and bronze in diameters from Ø15 mm to Ø54 mm.

1 Modern connection technology

The press connection technology used in KAN-therm Copper system ensures reliable and fast connections by pressing the fittings on the pipe. The assembly is carried out using common press machines, eliminating the process of threading or soldering individual components.

KAN-therm Copper system fittings are made of high-quality Cu-DHP copper and 2.109 bronze.

Joining the elements in the "press" technology allows to obtain connections with a minimized narrowing of the pipe cross-section, which significantly reduces the pressure loss in the whole installation and creates excellent hydraulic conditions.

2 Durable connection technology

KAN-therm Copper system leak tightness is ensured by special O-Ring seals and an M-profile crimping at the three main points of the moulded part.

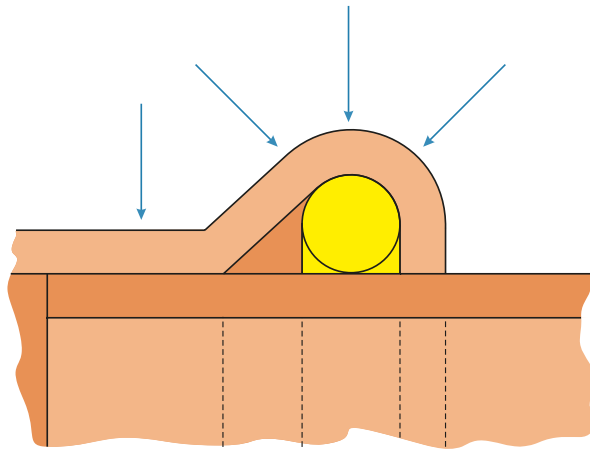

2.1 Applicability

- natural gas installations,
- LPG installations,
- compressed air systems,
- inert gases installations,
- vacuum.

2.2 Advantages

- simple and fast connection technology – “press”,
- the most popular on the market, very accurate, three-point M crimping profile,
- quick and secure assembly, without soldering or threading,
- wide range of diameters 15–54 mm,
- quick identification of diameter thanks to marking,
- special design of the fitting for easy fixing on the pipe,
- high corrosion resistance,
- high aesthetics of the installation.

3 Assembly of connections



1 Pipe cutting

Cut the pipe perpendicularly to its axis using a roll-cutter (the cut must be full without breaking off the cut pipe sections). It is permissible to use other tools provided that the cutting perpendicularity is maintained and that the cut edges are not damaged in the form of cracks, material losses and other deformations of the pipe cross-section.

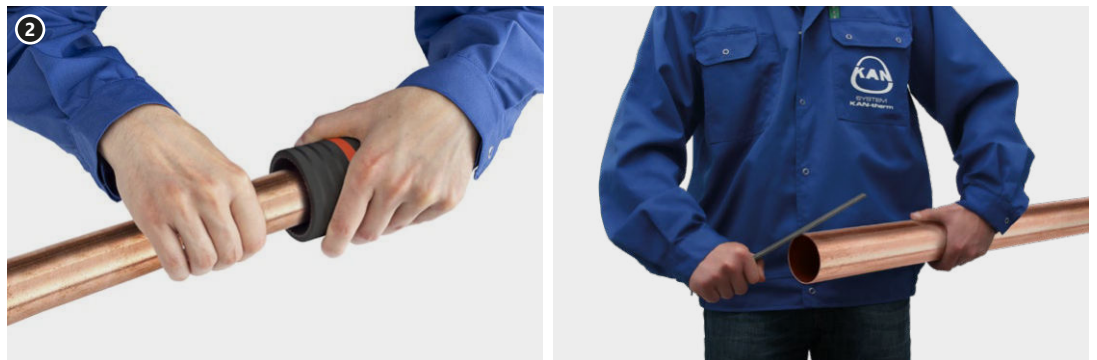

2 Chamfering of pipe edges

Using a handheld chamfer, chamfer the tip of the cut pipe inside and out and remove any swarf that may damage the O-Ring during installation.

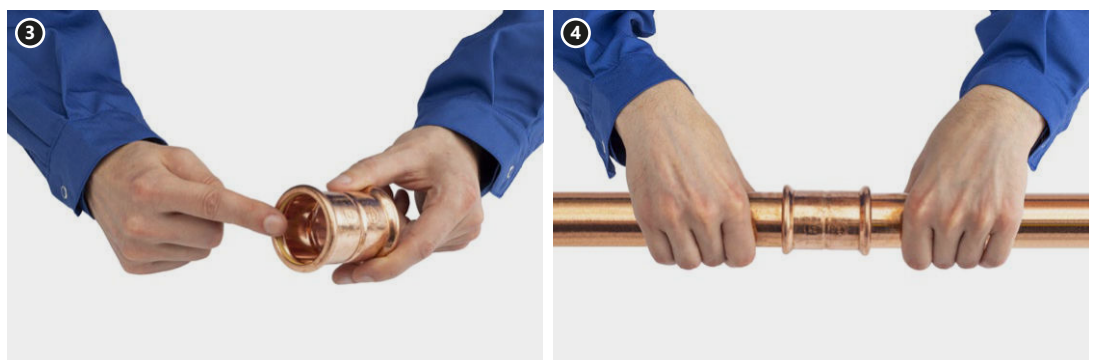

3 Control

Before installation, the presence of O-Rings in the fitting should be visually checked for damage, as well as for any contamination (swarf or other sharp objects) that may cause damage to the O-Rings during the pipe insertion phase. It is also necessary to make sure that the distance between adjacent fittings is not less than the permissible d_{\min} (Tab.1, Rys.1).

4 Installing the pipe and fitting

Before pressing, the pipe should be inserted axially into the coupling to the required depth (light rotary motion is permissible). The use of oils, greases and fats to facilitate the insertion of the pipe is prohibited (water or aqueous soap solution is permitted).



5 Mark the insertion depth of the pipe into the fitting

In order to achieve the proper strength of the connection, it is necessary to maintain the appropriate depth A (Tab. 1, Rys. 1) of inserting the pipe into the fitting. In the case of simultaneous assembly of many joints (sliding the pipes into the fittings) the pipe insertion depth in the fitting must be checked before pressing each subsequent joint. It is sufficient to check whether the pipe is inserted all the way. In order to ease the identification of pipe insertion depth in the fitting the simple marking technique can be applied (not required in construction conditions).

It consists of inserting the pipe into the fitting up to the limit and making a mark on pipe with a marker, right up to the edge of the fitting socket. After pressing, the marking must be still visible but as close as possible to the fitting.

Special templates are also used for determining the insertion depth, without necessity of matching with fitting.

! Note: Insertion depth marking templates are not part of the basic system offer and may be available depending on the specific market where the product is sold.

6 Pressing fittings

Before starting the pressing process, check the efficiency of the tools. The use of press jaws and machines supplied as parts of KAN-therm Copper Gas system is recommended.

The size of the pressing jaw must always be selected according to the diameter of the connection to be made. The pressing jaw should be placed on the fitting in such a way that the groove inside the jaw exactly covers the place where the O-Ring is seated in the fitting (convex part of the fitting). Once the press machine been started, the pressing process is automatic and cannot be stopped. If, for some reason, the pressing process is interrupted, the connection must be disassembled (cut out) and a new one must be made in the correct way. If the installer has tools other than supplied by KAN-therm Copper Gas system, the possibility of using them should be consulted with KAN's Technical Department.



7 Pressing of 42-54 mm fittings. Preparation of the jaws.

For pressing larger diameters (42, 54 mm) special Snap-on press collars are used.

The unfolded collar should be placed on the fitting. The jaws have a special groove in which the fitting should fit (the location of the O-Ring seal).

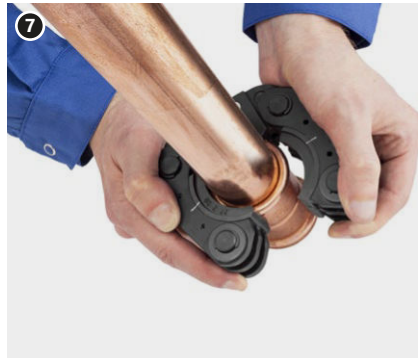

8 After correct seating collar on the fitting, connection is ready for pressing.

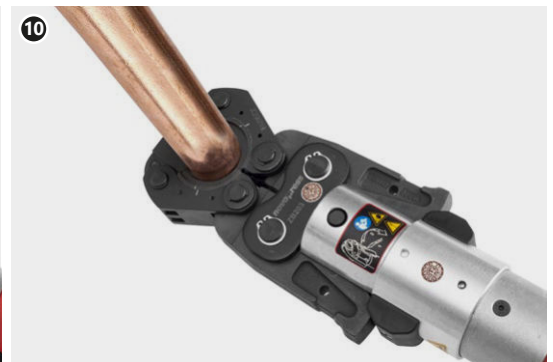

9 Connecting press tool to the collar

Press tool with a pre-mounted, suitable adapter must be connected to the collar.

It is essential to ensure that the pressing tool is connected to the collar in accordance with the instructions supplied with the tool.

Press machine may be started to fully press the connection.

10 Pressing

After starting the press tool, the pressing process must not be stopped. If, for some reason, the pressing process is interrupted, the connection must be disassembled (cut out) and a new one must be made in the correct way. After pressing, the press machine automatically returns to its original position. The arms of the pressing tool (adapter) must then be pulled out of the collar. In order to remove the flange from the fitting, it must be unlocked again and then disassembled.

Złącze przed i po zaprasowaniu

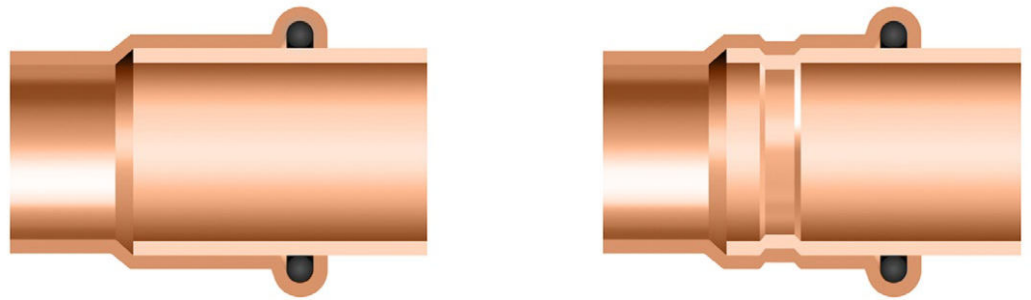

Mounting distances

Table. 1 Insertion depth of the pipe into the fitting and minimum distance between the press fittings

\varnothing [mm]	A [mm]	d_{\min} [mm]	c_{\min} [mm]
15	20	10	40
18	20	10	40
22	21	10	40
28	23	10	60
35	26	10	70
42	30	20	70
54	35	20	70

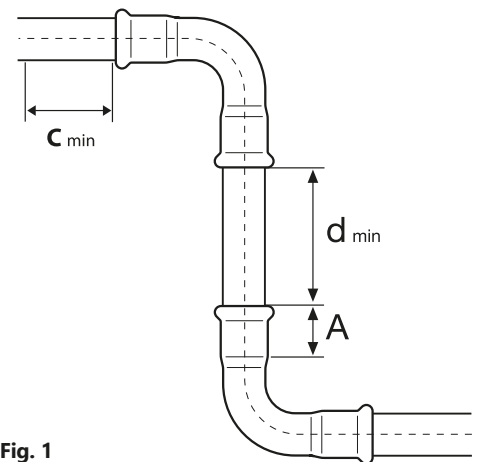

Fig. 1

- A – pipe insert depth,
- d_{\min} – minimum distance between fittings in order to ensure correct pressing,
- c_{\min} – minimum distance of fitting from the wall.

Table. 2 Minimum installation distances

Ø [mm]	Fig. 2		Fig. 3		
	a [mm]	b [mm]	a [mm]	b [mm]	c [mm]
15	56	20	75	25	28
18	60	20	75	25	28
22	65	25	80	31	35
28	75	25	80	31	35
35	75	30	80	31	44
42	115*	75*	115*	75*	75
54	120*	85*	120*	85*	85

*applies to 4-piece pressing jaws

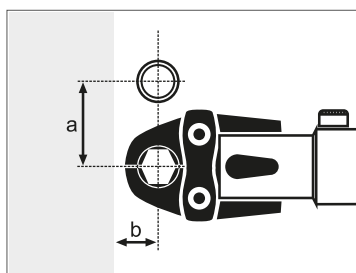

Fig. 2

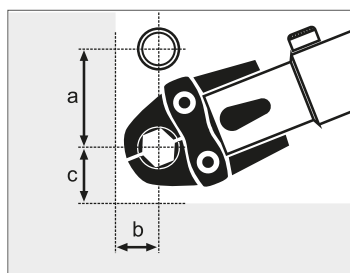

Fig. 3

4 Tools

Depending on the mounted diameter, KAN-therm system provides different tool configurations. In order to select an optimal set of tools, use the following selection table:

Table. 3 Tool selection table: KAN-therm Copper Gas system

Producer	Press machine		Średnica [mm]	Jaws/press collars		Adapter	
	Desc.	Code		Desc.	Code	Desc.	Code
NOVOPRESS	ACO203XL EFP203	1948267181 1948267210	15	[J] M	1948267135	-	-
			18	[J] M	1948267137	-	-
			22	[J] M	1948267139	-	-
			28	[J] M	1948267141	-	-
			35	[J] M	1948267143	-	-
			42	M	1948267119	ZB203	1948267000
	ACO102 ACO103	1948055007 1948267208	54	M	1948267121	-	-
			15	[J] M	1948267093	-	-
			18	[J] M	1948267095	-	-
			22	[J] M	1942121002	-	-
REMS	Power-Press SE Akku-Press Power Press ACC	1936267160 1936267152 1936267219	28	[J] M	1948267097	-	-
			35	[J] M	1942121004	-	-
			15	[J] M	1948267048	-	-
			18	[J] M	1948267052	-	-
			22	[J] M	1948267056	-	-
			28	[J] M	1948267061	-	-
			35	[J] M	1948267065	-	-
			42	[PR-3S] M *	-	Z2	-
54	[PR-3S] M *	-	Z2	-			

[J] - two segment jaw, other elements are press collars and may need additional adapter to combine with press machines
* the tool is not available in the KAN-therm offer

NOVOPRESS tools:

1. Battery-powered press ACO102
2. Battery-powered press ACO103
3. PB1 M15–35 mm jaws



1. Battery-powered press ACO203XL
2. PB2 M15–35 mm jaws
3. M35–54 Snap On collars

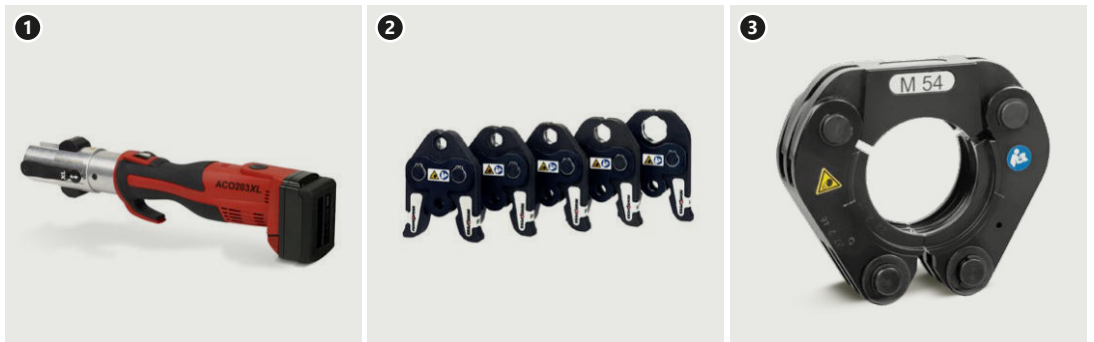

4. ZB203 adapter

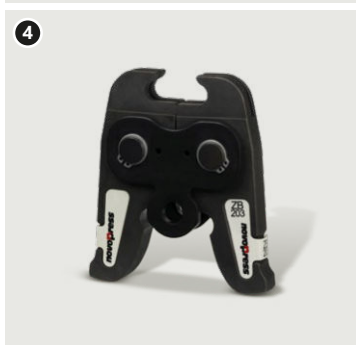

1. Electric press EFP203
2. PB2 M15–35 mm jaws
3. M35–54 Snap On collars

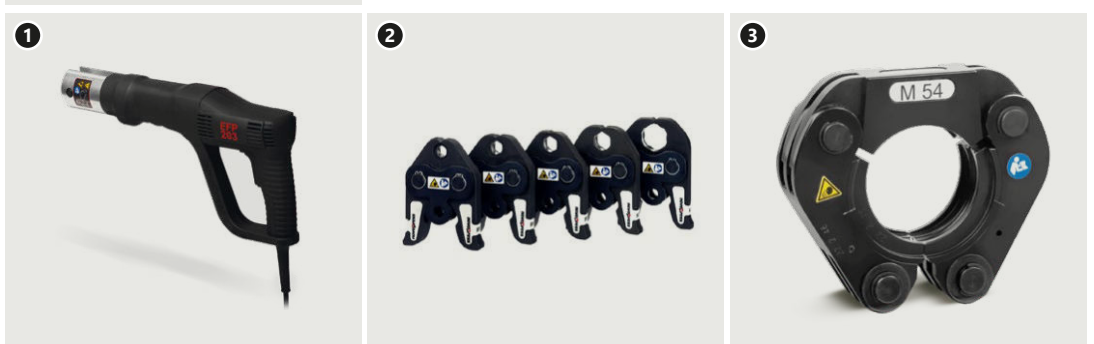

4. ZB203 adapter

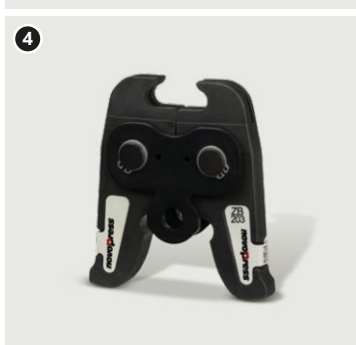

REMS tools:

1. Electric press Power-Press ACC
2. Battery-powered press Akku-Press
3. Electric press Power-Press SE



4. M12–35 mm jaws

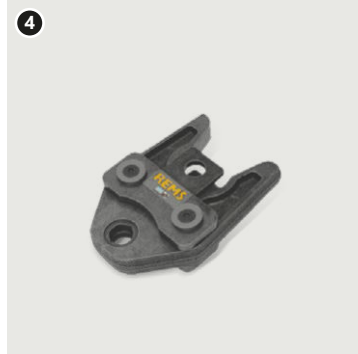

4.1 Tools – Safety

All tools must be used and used in accordance with their intended use and the manufacturer's operating instructions. Use for any other purpose is deemed to be improper. Intended use also requires observance of the operating instructions, the inspection and maintenance conditions and the relevant safety regulations in their current version. Any work using this tool that does not correspond to the intended use can lead to tool, accessories and pipes damage. The consequence may be leaks and/or damage to the connection point between the pipe and the fitting.

5 Detailed information

Kształtki – materiał

- copper Cu-DHP (CW024A) and bronze 2.109

Pipes - material and compliance

KAN-therm Copper system consists of fittings only. Therefore, the pipes used in cooperation with the system must meet specific requirements and have the appropriate properties:

- for gas installations – copper pipes according to EN 1057 R250/R290

Tab. 4 Copper pipes approved for use with KAN-therm Copper system

Ø [mm]	Wall thickness [mm]									
	0,6	0,7	0,8	0,9	1,0	1,1	1,2	1,5	2,0	2,5
15		R250			R250 R290					
18					R250 R290					
22				R250	R250 R290					
28				R250	R290		R250	R290		
35					R290		R250 R290	R290		
42					R290		R250 R290	R290		
54					R290		R250 R290		R290	

The values in the table refer to tensile strength (250 and 290 N/mm²). A distinction is made between medium-hard and hard tubes – R250 and R290 respectively. The higher the value, the harder the pipe material is.

O-Ringi

Name of the O-Ring	Properties and operating parameters	Application for seals
<p>NBR (yellow)</p> 	<ul style="list-style-type: none"> max. operating pressure 5 bar (inside and outside buildings) operating temperature: -20°C to +70°C 	<ul style="list-style-type: none"> gas installations (inner) LPG installations compressed air installations inert gas installations vacuum installations

Applications out of given scope should always be consulted with KAN Technical Department.

6 Data on elongation and thermal conductivity

Type of material	Thermal expansion coefficient	4 m segment expansion at 60 °C temperature difference	Thermal conductivity
	[mm/(m×K)]	[mm]	[W/(m ² ×K)]
Copper	0,0170	1,02	397

7 Recommendations for use

- KAN-therm Copper Gas system fittings made of copper Cu-DHP and bronze 2.109 cannot be used in installations that will be exposed to additional mechanical loads (e.g. hanging on pipelines, devastation, etc.),
- It is recommended to use ready-made bends and elbows 90° and 45° angle as part of KAN-therm Copper Gas system,
- If you are transporting a medium other than those included in this technical catalogue, the possibility of using KAN-therm Copper Gas system should be consulted with the KAN's Technical Department.
- Local regulations for the construction of gas installations must be followed.

8 Threaded connections, connection to other KAN-therm systems

KAN-therm Copper Gas system offers a full range of connectors with male and female threads.

In order not to strain pressed connection, it is recommended to make a threaded connection before pressing the connector.

Thread sealing

For threaded connections, use such amount of tow so that the thread peaks are still visible. If you use too much tow, the thread can be destroyed. Wrapping the tow just after the first thread reel avoids oblique screwing and damage to the thread.



Note:

Do not use chemical sealants or adhesives.

KAN-therm Copper Gas system components can be combined (through thread) with components made of other materials (see table below).

Possibilities of combining KAN-therm Copper Gas system with other materials

Type of installation	Pipes/fittings			
	Copper	Bronze/Brass	Carbon steel	Stainless steel
Copper Gas	yes	yes	yes	yes

Please note that direct joining of copper parts with stainless steel and galvanized carbon steel parts can lead to contact corrosion. This process can be eliminated by using the plastic inserts or independent metal inserts (bronze, brass) with minimal length of 50 mm (eg. using the brass ball valve).

9 Pipeline assembly

Maximum support span

Pipe diameter [mm]	Mounting distance [m]
15 × 1.0	1,25
18 × 1.0	1,50
22 × 1.2	2,00
28 × 1.2	2,25
35 × 1.5	2,75
42 × 1.5	3,00
54 × 1.5	3,50

Attachment points can be done as:

- shifting (sliding) points should allow unobstructed axial motion of pipelines (caused by the thermal elongation factor), which is why they should not be mounted next to joints (the minimal distance from the edge of a joint must be higher than the maximal elongation of the pipe section ΔL). The slidable point can be made as "unscrewed" metal clamps with rubber pads,
- PS fixed points – To form fixed points (PS) use zinc-plated steel clamps with elastic pads, ensuring precise and reliable stabilization of the pipe on its entire circumference. The clamp should fully and tightly enclose the pipe,
- attachment points preventing the pipeline from moving downwards: used if the pipeline movement on compensation arm length was blocked by required PP position.

9.1 Fixed (PS) and slidable (PP) points

- fixed points should prevent any movement of pipelines and should be fixed next to fittings (at both sides of a fitting, e.g. coupling, tee connection),
- fixed or slidable points cannot be fixed directly onto fittings,
- when fixing PSs near tee connections make sure that clamps blocking the pipeline are not fixed onto branches of smaller diameters than one dimension in relation to the pipeline (forces induced by large diameter pipes can damage small diameters),
- PPs enable only axial motion of the pipeline (they should be treated as fixed points for perpendicular direction to the pipeline axis) and should be made by clamps,
- PPs should not be fixed next to fittings because this may block thermal motions of the pipeline,
- remember that PPs prevent the pipeline from moving transverse to its axis and that is why their position may determine compensation arms length.

9.2 Elongation compensation

Along with water temperature rise ΔT pipelines become elongated by ΔL value. Thermal elongation ΔL causes pipeline deformation on expansion compensation length A. Expansion compensation length A should not cause excessive stresses in the pipeline and depends on the pipeline external diameter, thermal elongation ΔL and a linear expansion coefficient for a given material. Elongations ΔL in function of pipe length L and temperature rise ΔT are presented in table:

Total length elongation ΔL [mm] – KAN-therm Copper Gas system

L [m]	ΔT [°C]						
	10	20	30	40	50	60	70
1	0,17	0,34	0,51	0,68	0,85	1,02	1,19
2	0,34	0,68	1,02	1,36	1,70	2,04	2,38
3	0,51	1,02	1,53	2,04	2,55	3,06	3,57
4	0,68	1,36	2,04	2,72	3,40	4,08	4,76
5	0,85	1,70	2,55	3,40	4,25	5,10	5,95
6	1,02	2,04	3,06	4,08	5,10	6,12	7,14
7	1,19	2,38	3,57	4,76	5,95	7,14	8,33
8	1,36	2,72	4,08	5,44	6,80	8,16	9,52
9	1,53	3,06	4,59	6,12	7,65	9,18	10,71
10	1,70	3,40	5,10	6,80	8,50	10,20	11,90
12	2,04	4,08	6,12	8,16	10,20	12,24	14,28
14	2,38	4,76	7,14	9,52	11,90	14,28	16,66
16	2,72	5,44	8,16	10,88	13,60	16,32	19,04
18	3,06	6,12	9,18	12,24	15,30	18,36	21,42
20	3,4	6,80	10,20	13,60	17,00	20,40	23,80

Significant pipe length changes must be compensated by a use of special expansion joints, fixed points or supports. The elongation may be compensated by changing the routing of the pipeline as shown in picture A ('Z'-shaped compensator) and picture B ('U'-shaped compensator).

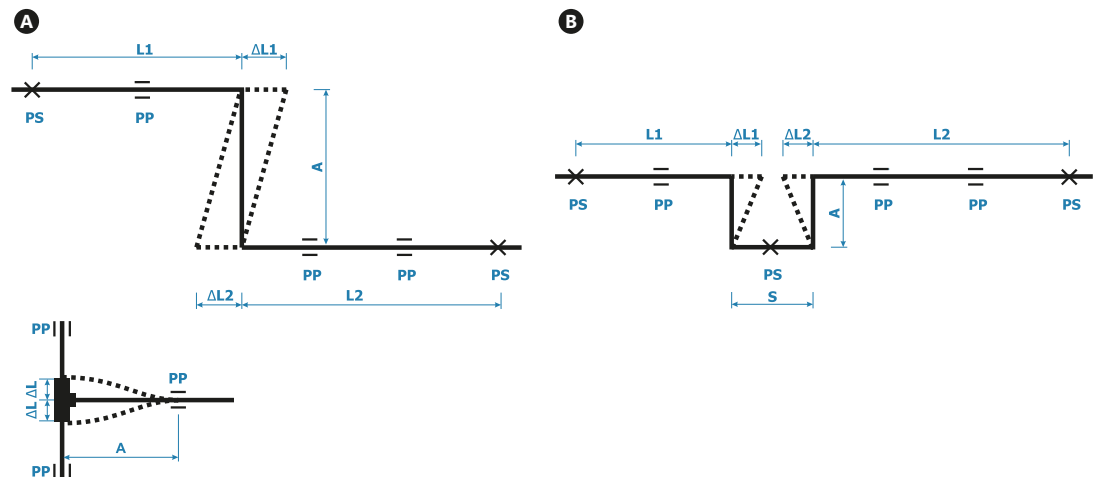

The following formula is used to calculate changes in length:

$$\Delta L = L \times \alpha \times \Delta T$$

ΔL – pipeline thermal elongation

L – initial pipeline length [m]

ΔT – temperature difference: working temp. and assembly temp. of the pipeline

α – Linear expansion coefficient 0,017 mm/mK

In case of large elongations, compensators or, in complex cases, “ Ω ” type compensation loops must be calculated. Compensators are calculated using the following formula:

$$A = k \times \sqrt{d_e \times \Delta L}$$

A – extension length

k – pipe material constant, 35 for copper pipes

d_e – external pipe diameter [mm]

ΔL – pipeline elongation that must be compensated [mm]

SYSTEM KAN-therm Copper Gas

Fittings

Male connector

GROUP: P

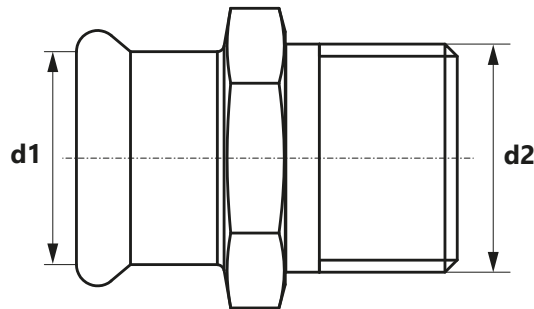

Size (d1 x d2)	Code	*			UM
15 R1/2"	2263045000		5	100	pc.
15 R3/4"	2263045001		5	100	pc.
18 R1/2"	2263045002		5	125	pc.
18 R3/4"	2263045003		5	100	pc.
22 R1/2"	2263045004		5	100	pc.
22 R3/4"	2263045005		5	70	pc.
22 R1"	2263045006		5	75	pc.
28 R3/4"	2263045007		5	75	pc.
28 R1"	2263045008		5	50	pc.
28 R1 1/4"	2263045009		5	50	pc.
35 R1"	2263045010		1	20	pc.
35 R1 1/4"	2263045011		1	20	pc.
42 R1 1/4"	2263045012		1	20	pc.
42 R1 1/2"	2263045013		1	15	pc.
54 R2"	2263045014		1	10	pc.

Union coupling

GROUP: P

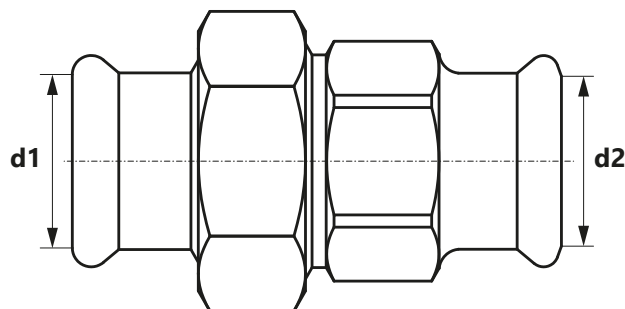

Size (d1 = d2)	Code	*			UM
15	2263065000		1	40	pc.
22	2263065001		1	20	pc.
28	2263065002		1	20	pc.
35	2263065003		1	10	pc.

coil
 bar
 pipes in tube
 bag
 carton box
 pallet
 new
 available soon

* on request (delivery time up to 4 weeks) | ** availability by individual arrangements | *** till stock ends

Female elbow 90°

GROUP: P

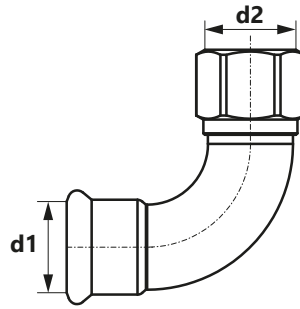

Size (d1 × d2)	Code	*			UM
15 Rp½"	2263069000		10	20	pc.
15 Rp¾"	2263069001		10	20	pc.
18 Rp½"	2263069002		1	25	pc.
18 Rp¾"	2263069003		1	25	pc.
22 Rp½"	2263069004		5	25	pc.
22 Rp¾"	2263069005		1	20	pc.
22 Rp1"	2263069006		5	15	pc.
28 Rp1"	2263069007		5	15	pc.
35 Rp1¼"	2263069008		1	10	pc.
42 Rp1½"	2263069009		1	10	pc.
54 Rp2"	2263069010		1	8	pc.

Male elbow 90°

GROUP: P

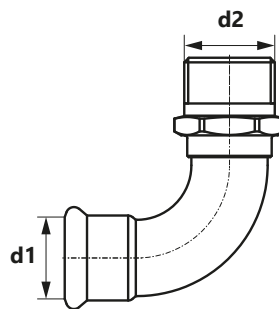

Size (d1 × d2)	Code	*			UM
15 R½"	2263070000		10	50	pc.
18 R½"	2263070001		1	25	pc.
18 R¾"	2263070002		1	25	pc.
22 R¾"	2263070003		1	20	pc.
28 R1"	2263070004		1	15	pc.
35 R1¼"	2263070005		1	10	pc.
42 R1½"	2263070006		1	10	pc.
54 R2"	2263070007		1	4	pc.

coil
 bar
 pipes in tube
 bag
 carton box
 pallet
 new
 available soon

* on request (delivery time up to 4 weeks) | ** availability by individual arrangements | *** till stock ends

Female tee

GROUP: P

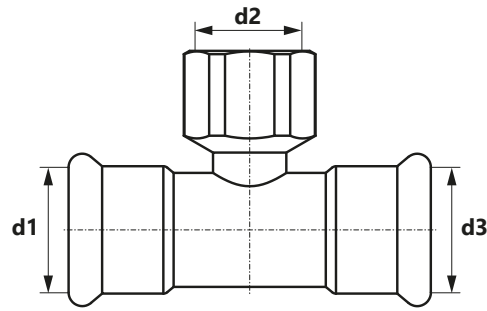

Size (d1 = d3 × d2)	Code	*			UM
15 Rp½"	2263258000		5	20	pc.
18 Rp½"	2263258001		1	20	pc.
22 Rp½"	2263258002		5	20	pc.
22 Rp¾"	2263258003		5	20	pc.
28 Rp½"	2263258004		5	15	pc.
28 Rp¾"	2263258005		1	15	pc.
35 Rp½"	2263258006		1	10	pc.
35 Rp1"	2263258007		1	10	pc.
42 Rp½"	2263258008		1	15	pc.
54 Rp½"	2263258009		1	5	pc.

Female connector

GROUP: P

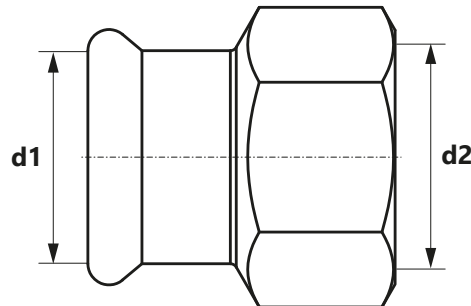

Size (d1 × d2)	Code	*			UM
15 Rp½"	2263044000		5	100	pc.
15 Rp¾"	2263044001		5	100	pc.
18 Rp½"	2263044002		5	100	pc.
18 Rp¾"	2263044003		5	100	pc.
22 Rp½"	2263044004		5	100	pc.
22 Rp¾"	2263044005		5	75	pc.
28 Rp1"	2263044006		5	50	pc.
35 Rp1¼"	2263044007		1	20	pc.
42 Rp1½"	2263044008		1	10	pc.
54 Rp2"	2263044009		1	8	pc.

coil
 bar
 pipes in tube
 bag
 carton box
 pallet
 new
 available soon

* on request (delivery time up to 4 weeks) | ** availability by individual arrangements | *** till stock ends

Female half union with flat gasket

GROUP: P

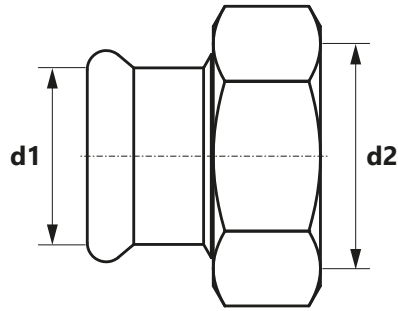

Size (d1 × d2)	Code	*			UM
15 G 7/8"	2263105000		5	80	pc.
28 G 1 3/8"	2263105001		5	40	pc.

Coupling

GROUP: P

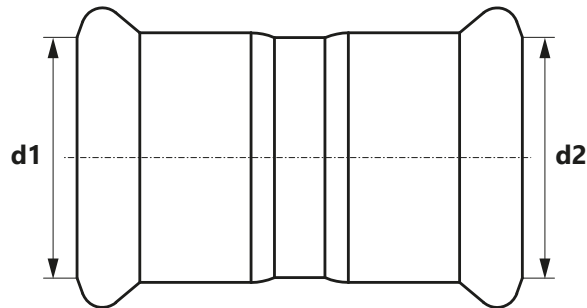

Size (d1 = d2)	Code	*			UM
15	2263245000		5	100	pc.
18	2263245001		5	100	pc.
22	2263245002		5	70	pc.
28	2263245003		5	50	pc.
35	2263245004		1	20	pc.
42	2263245005		1	10	pc.
54	2263245006		1	10	pc.

coil
 bar
 pipes in tube
 bag
 carton box
 pallet
 new
 available soon

* on request (delivery time up to 4 weeks) | ** availability by individual arrangements | *** till stock ends

Slip coupling

GROUP: P

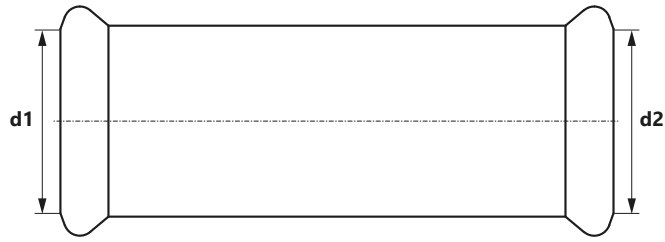

Size (d1=d2)	Code	*			UM
15	2263245007		5	75	pc.
18	2263245008		5	75	pc.
22	2263245009		5	50	pc.
28	2263245010		5	50	pc.
35	2263245011		1	15	pc.
42	2263245012		1	5	pc.
54	2263245013		1	10	pc.

Elbow 90°

GROUP: P

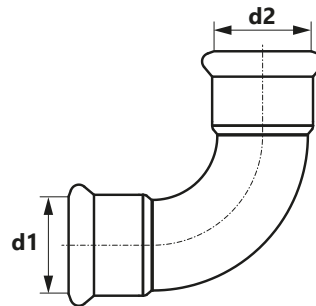

Size (d1=d2)	Code	*			UM
15	2263302000		5	80	pc.
18	2263302001		5	70	pc.
22	2263302002		5	60	pc.
28	2263302003		5	40	pc.
35	2263302004		1	10	pc.
42	2263302005		1	10	pc.
54	2263302006		1	8	pc.

coil
 bar
 pipes in tube
 bag
 carton box
 pallet
 new
 available soon

* on request (delivery time up to 4 weeks) | ** availability by individual arrangements | *** till stock ends

Nipple elbow 90°

GROUP: P

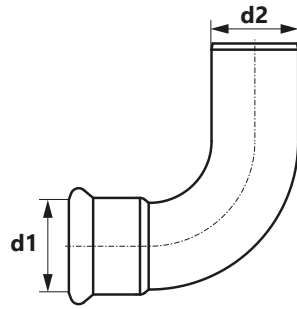

Size (d1=d2)	Code	*			UM
15	2263326000		5	80	pc.
18	2263326001		5	70	pc.
22	2263326002		5	50	pc.
28	2263326003		5	40	pc.
35	2263326004		1	10	pc.
42	2263326005		1	10	pc.
54	2263326006		1	8	pc.

Elbow 45°

GROUP: P

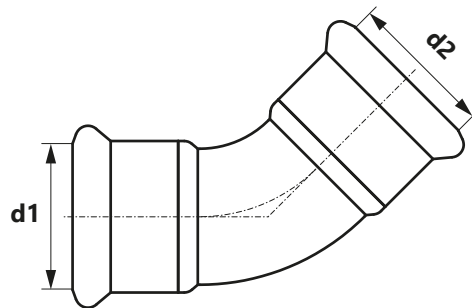

Size (d1=d2)	Code	*			UM
15	2263325007		5	100	pc.
18	2263325008		5	80	pc.
22	2263325009		5	60	pc.
28	2263325010		5	50	pc.
35	2263325011		1	15	pc.
42	2263325012		1	10	pc.
54	2263325013		1	5	pc.

coil
 bar
 pipes in tube
 bag
 carton box
 pallet
 new
 available soon

* on request (delivery time up to 4 weeks) | ** availability by individual arrangements | *** till stock ends

Nipple elbow 45°

GROUP: P

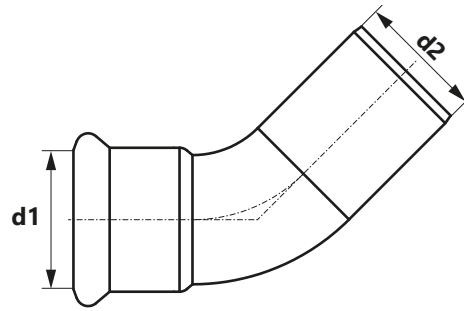

Size (d1=d2)	Code	*			UM
15	2263325000		5	100	pc.
18	2263325001		5	80	pc.
22	2263325002		5	60	pc.
28	2263325003		5	50	pc.
35	2263325004		1	15	pc.
42	2263325005		1	10	pc.
54	2263325006		1	5	pc.

Tee

GROUP: P

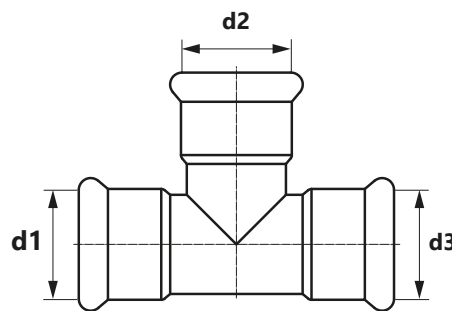

Size (d1=d2=d3)	Code	*			UM
15	2263257000		5	60	pc.
18	2263257001		5	75	pc.
22	2263257002		5	40	pc.
28	2263257003		5	25	pc.
35	2263257004		1	10	pc.
42	2263257005		1	10	pc.
54	2263257006		1	4	pc.

coil
 bar
 pipes in tube
 bag
 carton box
 pallet
 new
 available soon

* on request (delivery time up to 4 weeks) | ** availability by individual arrangements | *** till stock ends

Reducing tee

GROUP: P

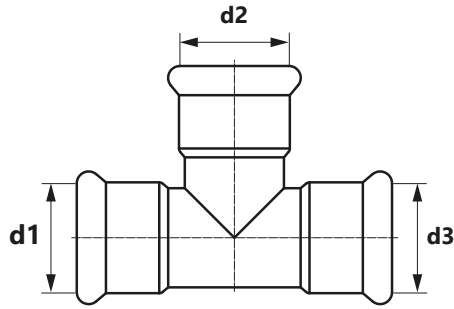

Size (d1/d2/d3)	Code	*			UM
18 / 15 / 18	2263260000		5	60	pc.
22 / 15 / 15	2263260013		5	40	pc.
22 / 15 / 22	2263260001		5	40	pc.
22 / 18 / 22	2263260002		5	40	pc.
22 / 22 / 15	2263260012		5	50	pc.
28 / 15 / 28	2263260003		5	25	pc.
28 / 22 / 28	2263260004		5	25	pc.
35 / 22 / 35	2263260005		1	15	pc.
35 / 28 / 35	2263260006		1	15	pc.
42 / 28 / 42	2263260008		1	5	pc.
42 / 35 / 42	2263260009		1	8	pc.
54 / 42 / 54	2263260011		1	5	pc.

Nipple reducer

GROUP: P

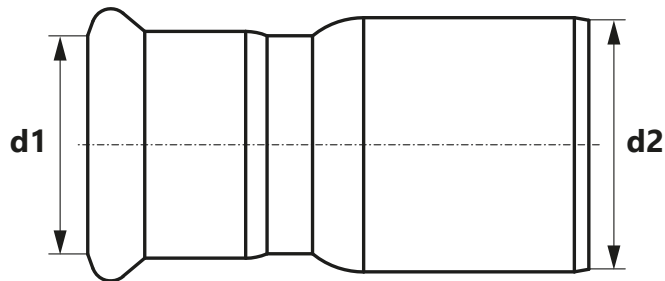

Size (d1/d2)	Code	*			UM
18 / 15	2263221000		5	100	pc.
22 / 15	2263221001		5	90	pc.
22 / 18	2263221002		5	80	pc.
28 / 15	2263221003		5	60	pc.
28 / 18	2263221004		5	75	pc.
28 / 22	2263221005		5	60	pc.
35 / 22	2263221006		1	30	pc.
35 / 28	2263221007		1	25	pc.
42 / 22	2263221008		1	20	pc.
42 / 28	2263221009		1	20	pc.
42 / 35	2263221010		1	10	pc.
54 / 35	2263221012		1	15	pc.
54 / 42	2263221013		1	10	pc.

coil
 bar
 pipes in tube
 bag
 carton box
 pallet
 new
 available soon

* on request (delivery time up to 4 weeks) | ** availability by individual arrangements | *** till stock ends

Female directly fixed wallplate elbow

GROUP: P

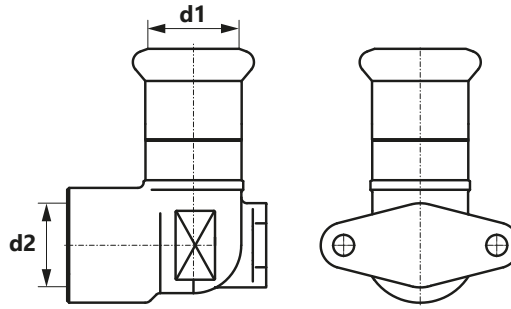

Size (d1×d2×l)	Code	*			UM
15 Rp1/2" L = 43 mm	2263286000		1	20	pc.
18 Rp1/2" L = 44 mm	2263286001		1	20	pc.
22 Rp3/4" L = 51 mm	2263286002		1	20	pc.

Stop end

GROUP: P

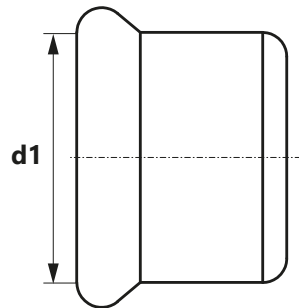

Size (d1)	Code	*			UM
15	2263250000		5	150	pc.
18	2263250001		5	130	pc.
22	2263250002		5	90	pc.
28	2263250003		5	75	pc.
35	2263250004		1	25	pc.
42	2263250005		1	20	pc.
54	2263250006		1	15	pc.

coil
 bar
 pipes in tube
 bag
 carton box
 pallet
 new
 available soon

* on request (delivery time up to 4 weeks) | ** availability by individual arrangements | *** till stock ends

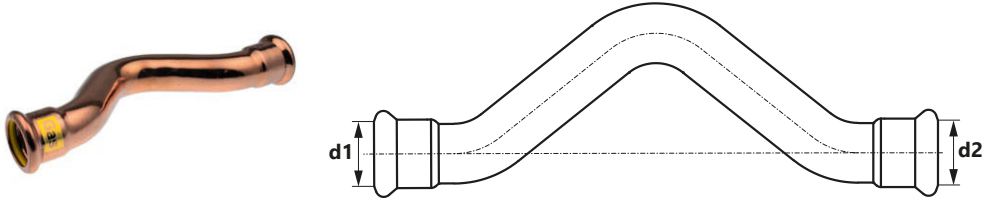

Size (d1=d2)	Code	*			UM
15	2263022000		5	50	pc.
22	2263022002		5	20	pc.

coil
 bar
 pipes in tube
 bag
 carton box
 pallet
 new
 available soon



* on request (delivery time up to 4 weeks) | ** availability by individual arrangements | *** till stock ends

Accessories

O-Ring NBR

GROUP: P



Size	Code	*			UM
15	2263182000		20	-	pc.
18	2263182001		20	-	pc.
22	2263182002		20	-	pc.
28	2263182003		20	-	pc.
35	2263182004		20	-	pc.
42	2263182005		20	-	pc.
54	2263182006		20	-	pc.

Note:

Operating temperature -20 °C +110 °C

Max. working pressure: 5 bar.

For use in gas installations (internal), LPG installations, compressed air installations, inert gas installations and vacuum installations (0,8 bar).

Tools

REMS pipe cutter

GROUP: K



Range	Code	*		UM
15-54	1948267025		1	pc.

REMS Cento pipe cutting machine

GROUP: K



Range	Code	*		UM
22-108	1948183001		1	pc.

Note:
Cutting wheel included.

Rothenberger stripping tool

GROUP: K



Range	Code	*		UM
12-54	1905267012		1	pc.

coil bar pipes in tube bag carton box pallet new available soon

* on request (delivery time up to 4 weeks) | ** availability by individual arrangements | *** till stock ends

Tool set - Novopress ACO103 BT battery-powered press + "M" profile jaws

GROUP: K



Range	Code	*		UM
15-28	1948055008		1	set

Set consists of:

- Battery-powered press - 1 pc.
- 1948267093 M15 jaws for press tool - 1 pc.
- 1948267095 M18 jaws for press tool - 1 pc.
- 1942121002 M22 jaws for press tool - 1 pc.
- 1948267097 M28 jaws for press tool - 1 pc.
- 1938267047 Charger - 1 pc.
- 1938267002 Battery 2 Ah - 2 pcs.
- Case

Novopress battery-powered press ACO203XL

GROUP: K



Range	Code	*		UM
12-54	1948267181		1	pc.

Set consists of:

- Battery 18 V/ 5.0 Ah Li-Ion Milwaukee - 2 pcs.
- Charger - 1 pc.
- Grease - 1 pc.
- Plastic case

Novopress EFP203 electric press

GROUP: K



Range	Code	*		UM
12-54	1948267210		1	pc.

Note:
Press tool is offered as a set with plastic case.

Novopress "M" profile PB2 jaws

GROUP: K



Size	Code	*		UM
15	1948267135		1	pc.
18	1948267137		1	pc.
22	1948267139		1	pc.
28	1948267141		1	pc.
35	1948267143		1	pc.

Note:
Jaws for EFP203 and ACO203XL press tools.

 coil
  bar
  pipes in tube
  bag
  carton box
  pallet
  new
  available soon

* on request (delivery time up to 4 weeks) | ** availability by individual arrangements | *** till stock ends

Novopress "M" profile Snap On collars

GROUP: K



Size	Code	*		UM
42	1948267119		1	pc.
54	1948267121		1	pc.

Note:

Collars for diameters 42 and 54 mm should be used with ZB201 and ZB203 adapters for ACO203XL and EFP203.

Novopress adapter ZB203

GROUP: K



Range	Code	*		UM
35-54	1948267000		1	pc.

Note:

For EFP203 and ACO203XL press tools.
Steel & Inox: 35-54 mm
Copper: 42-54 mm

REMS Power-Press ACC electric press

GROUP: K



Range	Code	*		UM
15-35	1936267219		1	pc.

Note:

Press tool is offered as a set with case.

coil bar pipes in tube bag carton box pallet new available soon

* on request (delivery time up to 4 weeks) | ** availability by individual arrangements | *** till stock ends

REMS Power-Press SE Basic Pack electric press

GROUP: K



Range	Code	*		UM
15-35	1936267160		1	pc.

Note:
Press tool is offered as a set with case.

REMS Akku Press battery-powered press

GROUP: K



Range	Code	*		UM
15-35	1936267152		1	pc.

Note:
Press tool is offered as a set with battery, charger and case. Jaws not included.

REMS "M" profile jaws

GROUP: K



Size	Code	*		UM
15	1948267048		1	pc.
18	1948267052		1	pc.
22	1948267056		1	pc.
28	1948267061		1	pc.
35	1948267065		1	pc.

Note:
Jaws for Power-Press SE, Akku-Press, Power-Press ACC press tools.

coil
 bar
 pipes in tube
 bag
 carton box
 pallet
 new
 available soon

* on request (delivery time up to 4 weeks) | ** availability by individual arrangements | *** till stock ends

Tool set - REMS Power-Press SE electric press + "M" profile jaws

GROUP: K



Range	Code	*		UM
15-35	1948267033		1	set

Set consists of:

- 1936267160 REMS Power-Press SE electric press
- 1948267048 „M” profile jaws 15 mm
- 1948267052 „M” profile jaws 18 mm
- 1948267056 „M” profile jaws 22 mm
- 1948267061 „M” profile jaws 28 mm
- 1948267065 „M” profile jaws 35 mm
- case

 coil
  bar
  pipes in tube
  bag
  carton box
  pallet
  new
  available soon

* on request (delivery time up to 4 weeks) | ** availability by individual arrangements | *** till stock ends



Install your **future**

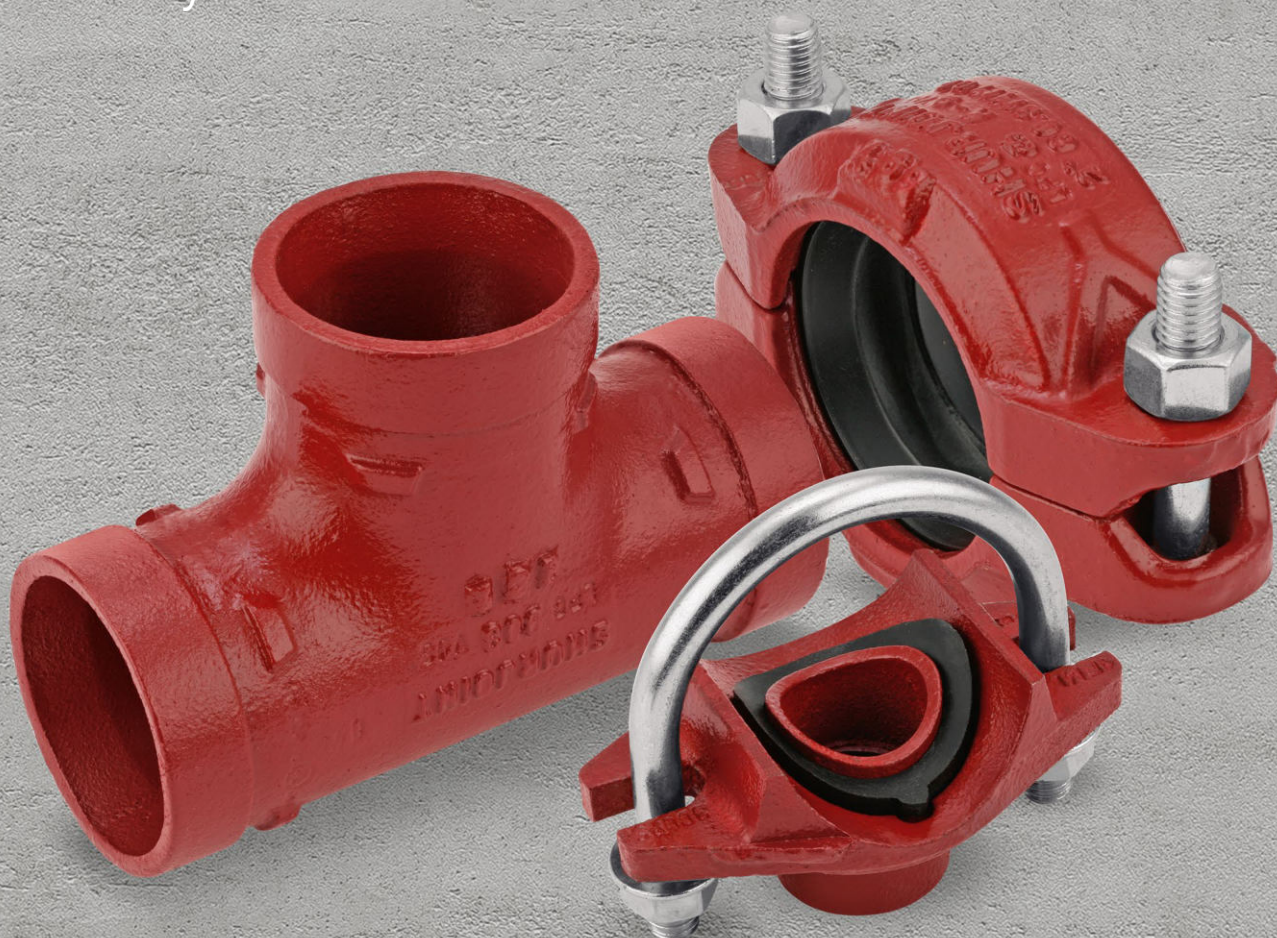

SYSTEM **KAN-therm**

Groove

System for special purposes

Table of contents

SYSTEM **KAN-therm** Groove

1	KAN-therm Groove system	110
2	Parametry techniczne	110
2.1	Technical parameters	110
2.2	KAN-therm Groove couplings and fittings	111
2.3	Bolts and nuts	112
2.4	Gaskets	114
2.5	Pressure performance data	116
2.6	Pipe end preparation	120
2.7	Installation guidelines	129
2.8	Design data - rigid and flexible couplings	148
2.9	Anchoring, hanging and brackets	153

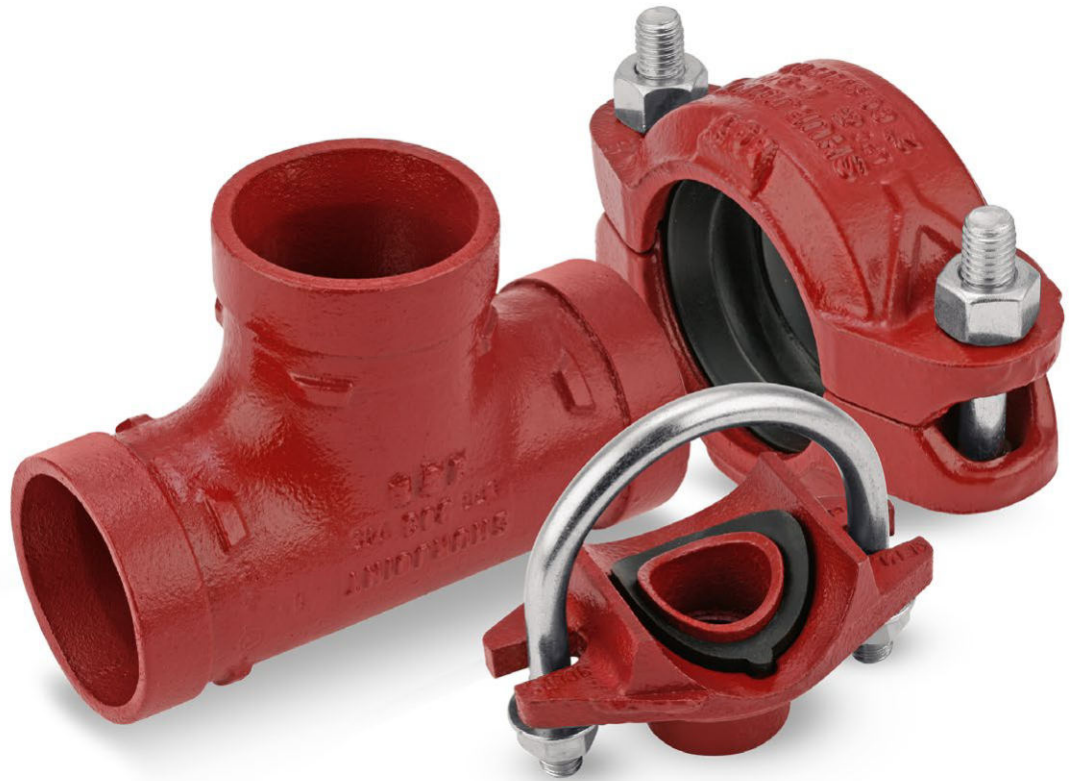

SYSTEM KAN-therm Groove

Integrated KAN-therm pipeline systems

All KAN-therm systems are characterized by consistently high quality as well as quick and uncomplicated assembly. Due to the full compatibility, it is possible to combine systems, achieving a range of diameters from DN8 to DN300 (12-323,9 mm).

Integrated KAN-therm pipeline systems are produced on many different production lines, the combination of which leads to the creation of the best quality technical solutions. These systems are applicable both in the transport of gases and liquids, in housing and commercial construction, industry, fire protection installations as well as shipbuilding and mining industries.

The right technology for proper application

In KAN we know that the right technology should be chosen for each application to ensure the best product quality, joining technique and maximum efficiency of the process. The KAN technical department will advise and guide you through the entire complicated process of project implementation. The use of the KAN-therm Groove system will allow for avoiding situations where it is necessary to combine products from different manufacturers.

1 KAN-therm Groove system

Thanks to a wide range of high-quality elements and expertise within the innovative system solutions, KAN-therm Groove offers a product that enables custom pipe installations in industrial, shipbuilding and mining industries. Reliable connections, uncomplicated assembly and security are our priorities.

KAN-therm Groove system advantages

- Up to 70% shorter assembly time compared to welding,
- Higher level of work safety, no need to work with open fire (welding),
- Systems adapted to pipelines made of steel, ductile iron,
- A wide range of high-quality products,
- Diameters from DN25 to DN300,
- Compatibility with other KAN-therm systems.

KAN-therm Groove products can be used in many types of pipelines - in compressed air and specialist systems used in mining and industry.

2 Technical parameters



compressed
air



vacuum
systems



industrial
systems

2.1 System types

2.1.1 Compressed air systems

KAN-therm Groove couplings and fittings with carbon steel or stainless steel pipes.

Galvanized elements of KAN-therm Groove system along with the galvanized steel pipes can be used for compressed air without oil content (maximal allowable concentration of synthetic oil up to 25 mg/m³, higher concentrations of synthetic oil as well as any content of mineral oil requires replacement of gaskets for butyl rubber NBR).

- **Gasket: EPDM (Class E)** - max. 25 mg/m³ of synthetic oil
Operating temperature: from -34 to +110 °C,
Operating pressure: depending on coupling type.
- **Gasket: NBR (Class T)**
Operating temperature: from -29 to +82 °C,
Operating pressure: depending on coupling type.

2.1.2 Industrial systems

KAN-therm Groove products can be used in many industrial applications, such as:

- aggressive media,
- sewage networks,
- water treatment,
- chemical lines,
- tunnel boreholes,
- reverse osmosis of sea water,
- irrigation.

For more information and details of specific projects please contact with KAN.



2.2 KAN-therm Groove couplings and fittings

2.2.1 Housing material

Ductile iron

Ductile iron is a perfect material for the production of grooved mechanical parts because it provides very high strength of manufactured components, in accordance with ASTM A536 and ASTM A395 standards.

Superior strength was achieved by crystallizing graphite in the shape of nodules. The result was ductile iron that had tensile and yield strength properties that were equal to or greater than some steel castings. This superior strength combined with ductile iron's excellent castability helped to reduce the weight and cost of many components.

Because of these advantages and benefits, many components have been converted from grey iron, malleable iron and steel castings to ductile iron over the past 60 years.

1. Ductile iron exceptional tensile strength and good castability.
2. Grey iron perfect castability but lower strength (higher brittleness).
3. Malleable iron more resistant than grey iron but characterized by worse castability.

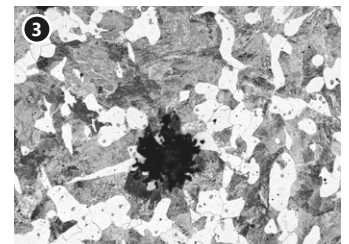
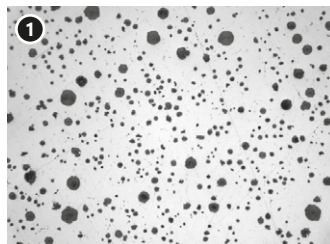

International specifications for the ductile iron, equivalent to ASTM A536 class 65-45-12 and/or ASTM A395 class 65-45-15 are:

- SAE J434: D4512,
- EN 1563: EN-GJS-450-10 or EN-GJS-450-15,
- JIS G5502: FCD450-10,
- SABS 936/937: SG42.

Specifications of A536 ductile iron, class 65-45-12 (UNS F33100)

Chemical composition*	
Carbon	3,0 – 3,9%
Silicon	2,5 – 3,0%
Manganese	0,1 – 0,4%
Phosphorus	< 0,07%
Sulphur	< 0,02%
Magnesium	0,03 – 0,05%
Chromium	< 0,1%
Physical properties	
Tensile strength	448 MPa
Yield strength	310 MPa
Elongation	12%

* Data is only approximate because the ASTM A536 standard does not specify requirements for chemical composition.

Specifications of A395 ductile iron, class 65-45-15 (UNS F33100)

Chemical composition	
Carbon	> 3,0%
Silicon	< 2,5%
Phosphorus	< 0,08%
Physical properties	
Tensile strength	448 MPa
Yield strength	310 MPa
Elongation	15%

2.3 Bolts and nuts



2.3.1 Carbon steel

KAN-therm Groove products use oval neck track bolts, in accordance with ASTM A449 or ASTM A183 standard class 2 and heavy duty nuts, in accordance with ASTM A563 standard class B, available with UNC threads or ISO metric threads. Bolts and nuts have an electrolytic zinc coating in silver chrome. Hot-dip galvanized bolts and nuts are also available on request.

Specifications of ASTM A449 standard, hardened and tempered steel bolts*

Chemical composition	
Carbon	0,28% – 0,55%
Manganese	> 0,60%
Phosphorus	< 0,040%
Sulphur	< 0,050%
Physical properties	
Tensile strength	825 MPa
Yield strength	635 MPa
Elongation	14%

* Equivalent to bolts with strength class 8.8 (ISO 898).

Specifications of the ASTM A563 standard, heavy duty hex nuts made of grade B carbon steel and alloy steel

Chemical composition	
Carbon	> 0,30%
Phosphorus	< 0,05%
Sulphur	< 0,06%
Physical properties	
Tensile strength	760 MPa
Yield strength	550 MPa
Elongation	12%

Specifications of ASTM A183 standard class 2 carbon steel track bolts

Chemical composition (bolts)	
Carbon	< 0,55%
Phosphorus	< 0,12%
Sulphur	< 0,15%
Physical properties	
Hardness	B69 (C32 Rockwell)

Bolt dimensions for KAN-therm Groove couplings

Pipe dimension		KAN-therm Groove couplings						
DN	mm	7705	7707	Z05	Z07	7706	7721 7722	79
25	33,7	M10 × 45	M10 × 55	-	-	-	-	½ × 2 ¾
32	42,4	M10 × 55	M12 × 75	M10 × 55	M10 × 55	M10 × 55	-	
40	48,3	M10 × 55	M12 × 60	M10 × 55	M10 × 55	-	-	½ × 2 ¾
50	60,3	M10 × 55	M12 × 75	M10 × 70	M10 × 70	M10 × 55	M10 × 55	¾ × 3 ½
65	73,0	M10 × 55	M12 × 75	M10 × 70	M10 × 70	M10 × 55	M12 × 75	¾ × 3 ½
65	76,1	M10 × 55	M12 × 75	M10 × 70	M10 × 70	M10 × 55	M12 × 75	-
80	88,9	M12 × 75	M12 × 75	M10 × 70	M12 × 75	M12 × 75	M12 × 75	¾ × 4 ¾
	108,0	M12 × 75	-	M10 × 70	-	-	-	-
100	114,3	M12 × 75	M16 × 90	M10 × 70	M12 × 75	M12 × 75	M12 × 75	-
	133,0	M16 × 90	-	M12 × 75	-	-	-	-
125	139,7	M16 × 90	M16 × 90	M12 × 75	M16 × 90	M16 × 90	M16 × 90	-
	141,3	M16 × 90	M16 × 90	M12 × 75	M16 × 90	M16 × 90	M16 × 90	¾ × 6 ½
150	168,3	M16 × 90	M20 × 120	M12 × 75	M16 × 90	M16 × 90	M16 × 135	¾ × 6 ½
200	219,1	M16 × 90 M20 × 120(7705H)	M20 × 120	M16 × 135	M20 × 120	M20 × 120	M20 × 120	¾ × 4 ¾
250	273,0	M20 × 120	¾ × 6 ½	-	¾ × 6 ½	-	-	¾ × 6 ½
300	323,9	¾ × 6 ½	¾ × 6 ½	-	¾ × 6 ½	-	-	1 × 6 ½

2.4 Gaskets



Over the past 50 years, we have witnessed a huge progress in the field of synthetic elastomer technology, thanks to which we can offer a diverse range of sealing materials for use in piping systems. The KAN-therm Groove System uses the finest materials available on the market that meet and exceed industry standards, such as ASTM D2000, AWWA C606, NSF61, IAPMO, etc. Our continuous research allows us to improve products to meet the changing requirements of the industry. Proper selection of a gasket for a specific application requires consideration of many factors to ensure maximum service life-span of the system.

2.4.1 Gasket materials

EPDM

The EPDM compound is considered the most waterproof, currently available elastomer. Gaskets made of this type of material are most often used in systems such as water up to 110°C, waste water, water with acids, deionized water and sea water. EPDM compound is not suitable for use with petroleum-based fuels and oils, hydrocarbon solvents and aromatic hydrocarbons.

Compound	Class	Colour code	Recommendations for use	Maximum range of temperature
EPDM	E		Suitable for water up to + 110°C, a mixture of water and acid, chlorinated water, deionized water, seawater and sewage water as well as diluted acids and compressed air without oil content. Do not use with petroleum products, mineral oils, solvents and aromatic hydrocarbons.	from -34°C to +110°C

Green strap

Warning! EPDM rubber gaskets are not recommended for use in steam systems, unless couplings or components are in places allowing for frequent gasket replacement. Incorrect selection of the gasket and its compound may result in a leakage or failure leading to personal or property damage. Gaskets should never be exposed to temperatures above rated values.

EPDM compound class E is compliant with ASTM D2000 standard. Peroxide cross-linking and hardening processes guarantee higher cross-linking density which ensures greater resistance to ageing processes than criteria provided for in AWWA C606 standard.



Note: EPDM gaskets used in systems with a high chlorine and/or chloramine content should be subjected to durability tests because not all materials are suitable for this type of application. In order to increase resistance to chloramine and chlorine it is recommended to use EPDM compounds with a higher content of saturated ethylene and a lower content of black carbon.

NBR*, BUNA-N and nitrile

They all represent the same copolymer of butadiene and acrylonitrile (ACN) which is inherently resistant to hydraulic fluids, lubricating oils, gear oils and other non-polar petroleum based compounds as well as water at temperature not exceeding 65 °C. NBR has low resistance to hot water and steam.

The T class NBR compound is manufactured based on ASTM D2000 standard and exceeds AWWA C606 standard. Class T is a general-purpose compound with an average ACN level.

Compound	Class	Colour code	Recommendations for use	Maximum range of temperature
NBR	T		It is suitable for use with petroleum products, mineral oils, vegetable oils, non-aromatic hydrocarbons, many acids and water (max. +65 °C). Seal suitable for use in compressed air systems containing large amounts of synthetic oils or mineral oils. Do not use in high-temperature water systems.	from -29 °C to +82 °C

Orange strip

2.4.2 Types of gaskets

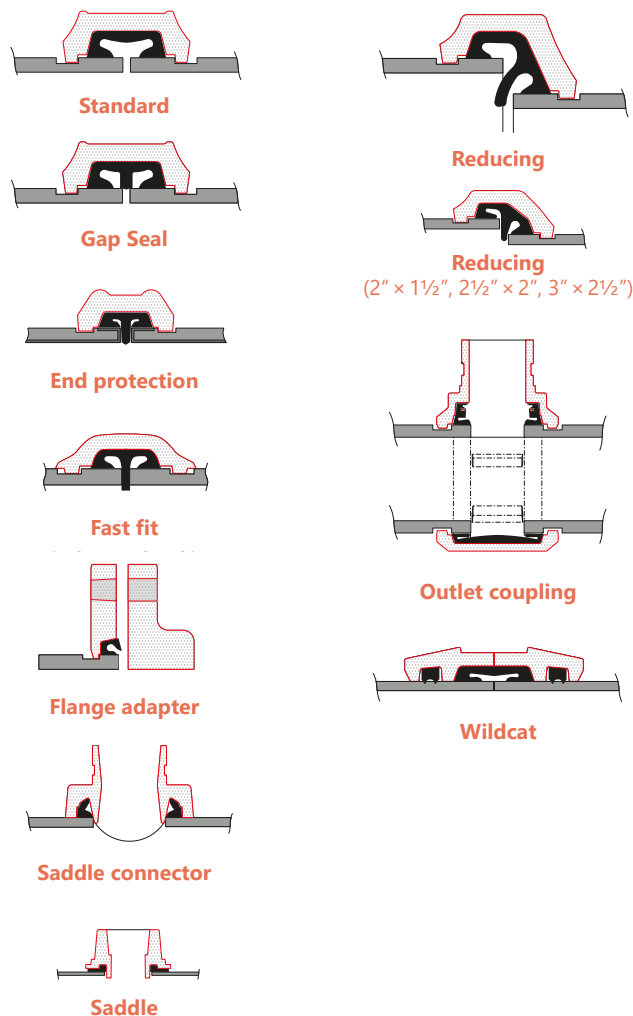

Proper selection of gaskets is essential for optimum performance of grooved couplings, flange adapters and saddle connectors. KAN-therm Groove couplings are used with various types of gaskets: standard, GapSeal (slotted), EP (with end-protection) and FF (quick-release). GapSeal gaskets are compatible with standard gaskets and can be used interchangeably. Always use gaskets that match the selected coupling model.

Standard gaskets ensure effective sealing under vacuum conditions up to 0,34 bar which can occur during emptying the system. In the case of continuous operation, with pressure lower than 0,34 bar, it is recommended to use EP gaskets (with end-protection) in combination with rigid couplings. For specific recommendations, please contact with KAN Technical Department.

For dry systems, it is recommended to use GapSeal class E gaskets which closes off the gap between the pipes or gasket cavity. This will prevent any remaining transported medium from entering the cavities. Rigid couplings are preferred for dry pipe, and vacuum applications. Reducing couplings are not recommended for these applications.

! NOTE! In the case of dry and cooling systems do not use standard grease. Instead, it is recommended to use a silicone-based grease that does not contain petroleum.

To prevent pinching (damaging) the gasket, it is recommended to use during assembly a lubricant available in the KAN-therm Groove offer. It is enough to apply a thin layer of grease to the outer wall of the gasket, lip of the gasket and/or the inside of the casing of the sealed element. Grease is available in containers with a capacity of 450 or 900 grams. It has NSF/ANSI 61 certificate.

2.5 Pressure performance data

The following tables present the maximum operating pressure values (P_{max}) for ductile iron couplings and flange adapters connected with carbon steel and stainless steel pipes. Ductile iron couplings can be used with a stainless steel pipe in a non-corrosive environment because the transported media do not come in direct contact with the coupling housing but only with the gasket.

For more information on the maximum operating pressure value for different combinations, please contact with KAN Technical Department.

Operating pressure values in bars (psi) for ductile iron couplings connected with carbon steel pipes **grooved by rolling**

Pipe dimension				Series of types	Nominal wall thickness		Coupling type												
							7705		7707		Z05		Z07		7706		7041		
DN	inch/mm	mm	inches		mm	inches	bar	psi	bar	psi	bar	psi	bar	psi	bar	psi	bar	psi	
25	1	33,7	1,315	5	1,7	0,065	20	300	35	500	-	-	-	-	-	-	-	-	
				10	2,80	0,109	28	400	52	750	-	-	-	-	-	-	-	-	-
				STD	3,40	0,13	35	500	69	1000	-	-	-	-	-	-	-	-	-
32	1 ¼	42,4	1,660	5	1,65	0,07	20	300	35	500	17	250	28	400	-	-	-	-	
				10	2,77	0,11	28	400	52	750	28	400	42	600	-	-	-	-	
				STD	3,56	0,14	35	500	69	1000	35	500	52	750	-	-	-	-	
40	1 ½	48,3	1,900	5	1,65	0,07	20	300	35	500	17	250	28	400	20	300	-	-	
				10	2,77	0,11	28	400	52	750	28	400	42	600	24	350	-	-	
				STD	3,68	0,15	35	500	69	1000	35	500	52	750	35	500	-	-	
50	2	60,3	2,375	5	1,65	0,07	20	300	35	500	17	250	28	400	20	300	NR	NR	
				10	2,77	0,11	28	400	52	750	28	400	42	600	24	350	17	250	
				STD	3,91	0,15	35	500	69	1000	35	500	52	750	35	500	20	300	
	2 ½	73,0	2,875	5	2,11	0,08	20	300	35	500	17	250	28	400	20	300	NR	NR	
				10	3,05	0,12	28	400	42	600	28	400	42	600	24	350	17	250	
				STD	5,16	0,20	35	500	69	1000	35	500	52	750	35	500	20	300	
65	76,1 mm	76,1	3,000	5	2,11	0,08	20	300	35	500	17	250	28	400	20	300	NR	NR	
				10	3,05	0,12	28	400	42	600	28	400	42	600	24	350	17	250	
				STD	5,16	0,20	35	500	69	1000	35	500	52	750	35	500	20	300	
80	3	88,9	3,500	5	2,11	0,08	20	300	35	500	17	250	28	400	20	300	NR	NR	
				10	3,05	0,12	28	400	42	600	28	400	42	600	24	350	17	250	
				STD	5,49	0,22	35	500	69	1000	35	500	52	750	35	500	20	300	
	108 mm	108,0	4,252	5	2,11	0,08	20	300	-	-	-	-	-	-	-	-	-	-	
				10	3,05	0,12	28	400	-	-	-	-	-	-	-	-	-	-	
				STD	5,74	0,23	35	500	-	-	-	-	-	-	-	-	-		
100	4	114,3	4,500	5	2,11	0,08	20	300	28	400	14	200	28	400	17	250	NR	NR	
				10	3,05	0,12	28	400	42	600	28	400	42	600	20	300	17	250	
				STD	6,02	0,24	35	500	69	1000	35	500	52	750	35	500	20	300	
	133 mm	133,0	5,236	5	2,77	0,11	17	250	-	-	-	-	-	-	-	-	-		
				10	3,40	0,13	24	350	-	-	-	-	-	-	-	-			
				STD	6,55	0,26	31	450	-	-	-	-	-	-	-	-			
125	139,7 mm	139,7	5,500	5	2,77	0,11	17	250	24	350	12	175	24	350	17	250	NR	NR	
				10	3,40	0,13	24	350	35	500	20	300	35	500	20	300	17	250	
				STD	6,55	0,26	31	450	69	1000	24	350	52	750	28	400	20	300	
	5	141,3	5,563	5	2,77	0,11	17	250	24	350	12	175	24	350	17	250	NR	NR	
				10	3,40	0,13	24	350	35	500	20	300	35	500	20	300	17	250	
				STD	6,55	0,26	31	450	69	1000	24	350	52	750	28	400	20	300	
159 mm	159,0	6,260	5	2,77	0,11	17	250	-	-	-	-	-	-	-	-	-			
			10	3,40	0,13	24	350	-	-	-	-	-	-	-	-				
			STD	7,11	0,28	31	450	-	-	-	-	-	-	-	-				
150	6	168,3	6,625	5	2,77	0,11	17	250	20	300	12	175	20	300	12	175	NR	NR	
				10	3,40	0,13	24	350	31	450	20	300	28	400	20	300	17	250	
				STD	7,11	0,28	31	450	69	1000	24	350	48	700	28	400	20	300	
200	8	219,1	8,625	5	2,77	0,11	14	200	17	250	10	150	17	250	12	175	NR	NR	
				10	3,76	0,15	17	250	24	350	20	300	24	350	20	300	14	200	
				STD	8,18	0,32	20	300	55	800	24	350	42	600	28	400	20	300	
250	10	273,0	10,750	5	3,40	0,13	12	175	14	200	-	-	14	200	-	-	NR	NR	
				10	4,19	0,17	14	200	20	300	-	-	20	300	-	-	14	200	
				STD	9,27	0,37	20	300	55	800	-	-	35	500	-	-	20	300	
300	12	323,9	12,750	5	4,06	0,16	12	175	14	200	-	-	10	150	-	-	NR	NR	
				10	4,57	0,18	14	200	20	300	-	-	17	250	-	-	14	200	
				STD	9,53	0,38	20	300	55	800	-	-	28	400	-	-	20	300	

Operating pressure values in bars (psi) for ductile iron couplings connected with carbon steel pipes grooved by cutting

Pipe dimension				Nominal wall thickness		Coupling type												
						7705		7707		Z05		Z07		7706		7041		
DN	inch/mm	mm	inches	Series of types	mm	inches	bar	psi	bar	psi	bar	psi	bar	psi	bar	psi	bar	psi
25	1	33,7	1,315	STD	3,40	0,13	42	600	69	1000	-	-	-	-	-	-	-	-
				XS	4,55	0,18	42	600	69	1000	-	-	-	-	-	-	-	-
32	1 ¼	42,4	1,66	STD	3,56	0,14	42	600	69	1000	42	600	52	750	-	-	-	-
				XS	4,85	0,19	42	600	69	1000	42	600	52	750	-	-	-	-
40	1 ½	48,3	1,9	STD	3,68	0,15	42	600	69	1000	42	600	52	750	35	500	-	-
				XS	5,08	0,20	42	600	69	1000	42	600	52	750	35	500	-	-
50	2	60,3	2,375	STD	3,91	0,15	42	600	69	1000	42	600	52	750	35	500	20	300
				XS	5,54	0,22	42	600	69	1000	42	600	52	750	35	500	20	300
	2 ½	73,0	2,875	STD	5,16	0,20	42	600	69	1000	42	600	52	750	35	500	20	300
				XS	7,01	0,28	42	600	69	1000	42	600	52	750	35	500	20	300
65	76,1 mm	76,1	3,000	STD	5,16	0,20	42	600	69	1000	42	600	52	750	35	500	20	300
				XS	7,01	0,28	42	600	69	1000	42	600	52	750	35	500	20	300
80	3	88,9	3,500	STD	5,49	0,22	42	600	69	1000	42	600	52	750	35	500	20	300
				XS	7,62	0,30	42	600	69	1000	42	600	52	750	35	500	20	300
	108 mm	108,0	4,252	STD	5,74	0,23	42	600	-	-	-	-	-	-	-	-	-	-
				XS	8,08	0,32	42	600	-	-	-	-	-	-	-	-	-	-
100	4	114,3	4,500	STD	6,02	0,24	42	600	69	1000	42	600	52	750	35	500	20	300
				XS	8,56	0,34	42	600	69	1000	42	600	52	750	35	500	20	300
	133 mm	133,0	5,236	STD	6,02	0,24	31	450	-	-	-	-	-	-	-	-	-	-
				XS	8,56	0,34	31	450	-	-	-	-	-	-	-	-	-	-
125	139,7 mm	139,7	5,500	STD	6,55	0,26	31	450	69	1000	31	450	52	750	28	400	20	300
				XS	9,53	0,38	31	450	69	1000	31	450	52	750	28	400	20	300
	5	141,3	5,563	STD	6,55	0,26	31	450	69	1000	31	450	52	750	28	400	20	300
				XS	9,53	0,38	31	450	69	1000	31	450	52	750	28	400	20	300
159 mm	159	6,260	STD	7,11	0,28	31	450	-	-	-	-	-	-	-	-	-	-	
			XS	10,97	0,43	31	450	-	-	-	-	-	-	-	-	-	-	
150	6	168,3	6,625	STD	7,11	0,28	31	450	69	1000	31	450	48	700	28	400	20	300
				XS	10,97	0,43	31	450	69	1000	31	450	48	700	28	400	20	300
200	8	219,1	8,625	STD	8,18	0,32	31	450	55	800	31	450	42	600	28	400	20	300
				XS	12,70	0,50	31	450	55	800	31	450	42	600	28	400	20	300
250	12	273,0	10,750	STD	9,27	0,37	24	350	55	800	-	-	35	500	-	-	20	300
				XS	12,70	0,50	24	350	55	800	-	-	35	500	-	-	20	300
300	12	323,9	12,750	STD	9,27	0,37	24	350	55	800	-	-	28	400	-	-	20	300
				XS	12,70	0,50	24	350	55	800	-	-	28	400	-	-	20	300

Operating pressure values in bars (psi) for ductile iron couplings connected with stainless steel pipes grooved by rolling

Pipe dimension				Nominal wall thickness		Coupling type													
						7705		7707		Z05		Z07		7706		7041			
DN	inch/mm	mm	inches	Series of types	mm	inches	bar	psi	bar	psi	bar	psi	bar	psi	bar	psi	bar	psi	
25	1	33,7	1,315	5	1,7	0,065	17	250	22	325	-	-	-	-	-	-	-	-	
				10	2,8	0,109	20	300	31	450	-	-	-	-	-	-	-	-	-
				40	3,4	0,133	31	450	48	300	-	-	-	-	-	-	-	-	-
32	1 1/4	42,4	1,660	5	1,7	0,065	17	250	22	325	17	250	20	300	-	-	-	-	
				10	2,8	0,109	20	300	31	450	20	300	35	500	-	-	-	-	
				40	3,6	0,140	31	450	48	300	31	450	48	700	-	-	-	-	
40	1 1/2	48,3	1,900	5	1,7	0,065	17	250	22	325	17	250	20	300	17	250	-	-	
				10	2,8	0,109	20	300	31	450	20	300	35	500	20	300	-	-	
				40	3,7	0,145	31	450	48	300	31	450	48	700	24	350	-	-	
50	2	60,3	2,375	5	1,7	0,065	17	250	22	325	17	250	20	300	17	250	12	175	
				10	2,8	0,109	20	300	31	450	20	300	35	500	20	300	19	275	
				40	3,9	0,154	31	450	48	300	31	450	48	700	24	350	19	275	
	2 1/2	73,0	2,875	5	2,1	0,083	17	250	22	325	17	250	20	300	17	250	12	175	
				10	3,0	0,120	20	300	31	450	20	300	35	500	20	300	19	275	
				40	5,2	0,203	31	450	48	300	31	450	48	700	24	350	19	275	
65	2 1/2	76,1	3,000	5	2,1	0,083	17	250	22	325	17	250	20	300	17	250	12	175	
				10	3,0	0,120	20	300	31	450	20	300	35	500	20	300	19	275	
				40	5,2	0,203	31	450	48	300	31	450	48	700	24	350	19	275	
80	3	88,9	3,500	5	2,1	0,083	17	250	22	325	17	250	20	300	17	250	12	175	
				10	3,0	0,120	20	300	31	450	20	300	35	500	20	300	19	275	
				40	5,5	0,216	31	450	48	300	31	450	48	700	24	350	19	275	
100	4	114,3	4,500	5	2,1	0,083	14	200	17	250	14	200	17	250	14	200	12	175	
				10	3,0	0,120	20	300	28	400	20	300	28	400	17	250	19	275	
				40	6,0	0,237	31	450	48	700	31	450	48	700	20	300	19	275	
125	5	139,7	5,500	5	2,8	0,109	NR	NR	NR	NR	NR	NR	NR	NR	NR	NR	12	175	
				10	3,4	0,134	14	200	20	300	14	200	20	300	17	250	14	200	
				40	6,6	0,258	20	300	42	600	20	300	42	600	20	300	19	275	
	5	141,3	5,563	5	2,8	0,109	NR	NR	NR	NR	NR	NR	NR	NR	NR	NR	NR	12	175
				10	3,4	0,134	14	200	20	300	14	200	20	300	17	250	14	200	
				40	6,6	0,258	20	300	42	600	20	300	42	600	20	300	19	275	
150	6	168,3	6,625	5	2,8	0,109	NR	NR	NR	NR	NR	NR	NR	NR	NR	NR	9	125	
				10	3,4	0,134	9	125	14	200	9	125	14	200	12	175	14	200	
				40	7,1	0,280	20	300	35	500	20	300	35	500	20	300	17	250	
200	8	219,1	8,625	5	2,8	0,109	NR	NR	NR	NR	NR	NR	NR	NR	NR	NR	NR	NR	
				10	3,8	0,148	7	100	10	150	7	100	10	150	12	175	NR	NR	
				40	8,2	0,322	20	300	31	450	20	300	28	400	20	300	14	200	
250	10	273,0	10,750	5	3,4	0,134	NR	NR	NR	NR	-	-	NR	NR	-	-	NR	NR	
				10	4,2	0,165	NR	NR	9	125	-	-	7	100	-	-	NR	NR	
				40	9,3	0,365	14	200	28	400	-	-	20	300	-	-	14	200	
300	12	323,9	12,750	5	4,0	0,156	NR	NR	NR	NR	-	-	NR	NR	-	-	NR	NR	
				10	4,6	0,180	NR	NR	9	125	-	-	7	100	-	-	NR	NR	
				40	9,5	0,375	14	200	28	400	-	-	17	250	-	-	14	200	

Operating pressure values in bars (psi) for ductile iron couplings connected with stainless steel pipes grooved by cutting

Pipe dimension				Nominal wall thickness		Coupling type													
						7705		7707		Z05		Z07		7706		7041			
DN	inch/mm	mm	inches	Series of types	mm	inches	bar	psi	bar	psi	bar	psi	bar	psi	bar	psi	bar	psi	
25	1	33,7	1,315	40S	3,40	0,13	42	600	52	750	-	-	-	-	-	-	-	-	-
				80S	4,55	0,18	42	600	52	750	-	-	-	-	-	-	-	-	-
32	1 ¼	42,4	1,660	40S	3,56	0,14	42	600	52	750	42	600	52	750	-	-	-	-	-
				80S	4,85	0,19	42	600	52	750	42	600	52	750	-	-	-	-	-
40	1 ½	48,3	1,900	40S	3,68	0,15	42	600	52	750	42	600	52	750	35	500	-	-	-
				80S	5,08	0,20	42	600	52	750	42	600	52	750	35	500	-	-	-
50	2	60,3	2,375	40S	3,91	0,15	42	600	52	750	42	600	52	750	35	500	20	300	300
				80S	5,54	0,22	42	600	52	750	42	600	52	750	35	500	20	300	300
65	2 ½	73,0	2,875	40S	5,16	0,20	42	600	52	750	42	600	52	750	35	500	20	300	300
				80S	7,01	0,28	42	600	52	750	42	600	52	750	35	500	20	300	300
65	76,1 mm	76,1	3,000	40S	5,16	0,20	42	600	52	750	42	600	52	750	35	500	20	300	300
				80S	7,01	0,28	42	600	52	750	42	600	52	750	35	500	20	300	300
80	3	88,9	3,500	40S	5,49	0,22	42	600	52	750	42	600	52	750	35	500	20	300	300
				80S	7,62	0,30	42	600	52	750	42	600	52	750	35	500	20	300	300
100	4	114,3	4,500	40S	6,02	0,24	42	600	52	750	42	600	52	750	35	500	20	300	300
				80S	8,56	0,34	42	600	52	750	42	600	52	750	35	500	20	300	300
125	139,7 mm	139,7	5,500	40S	6,55	0,26	31	450	52	750	31	450	52	750	28	400	20	300	300
				80S	9,53	0,38	31	450	52	750	31	450	52	750	28	400	20	300	300
125	5	141,3	5,563	40S	6,55	0,26	31	450	52	750	31	450	52	750	28	400	20	300	300
				80S	9,53	0,38	31	450	52	750	31	450	52	750	28	400	20	300	300
150	6	168,3	6,625	40S	7,11	0,28	31	450	52	750	31	450	48	700	28	400	20	300	300
				80S	10,97	0,43	31	450	52	750	31	450	48	700	28	400	20	300	300
200	8	219,1	8,625	40S	8,18	0,32	31	450	42	600	31	450	42	600	28	400	20	300	300
				80S	12,70	0,50	31	450	42	600	31	450	42	600	28	400	20	300	300
250	10	273,0	10,750	40S	9,27	0,37	24	350	42	600	-	-	35	500	-	-	20	300	300
				80S	12,70	0,50	24	350	42	600	-	-	35	500	-	-	20	300	300
300	12	323,9	12,750	40S	9,27	0,37	24	350	42	600	-	-	28	400	-	-	20	300	300
				80S	12,70	0,50	24	350	42	600	-	-	28	400	-	-	20	300	300

2.6 Pipe end preparation

2.6.1 Pipe grooving

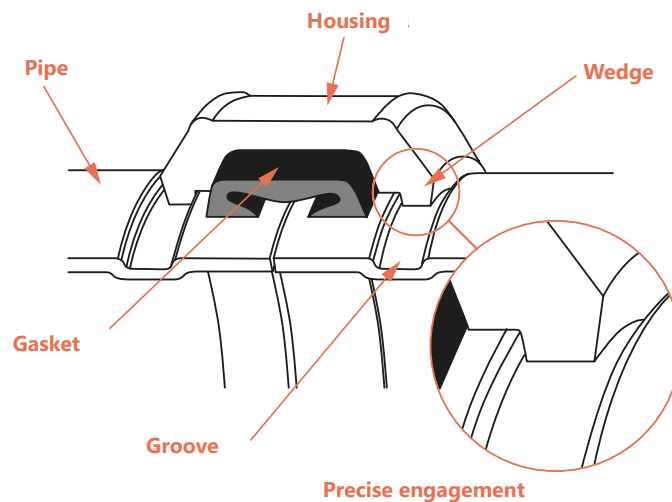

Grooving by rolling

Grooved pipe systems require grooving by cutting or rolling to connect the pipe ends. The engagement of the housing keys in the grooves is an essential issue in the context of providing a secure and tight coupling. The grooves must be correctly made to ensure optimum coupling performance.

Nominal pipe dimension

KAN-therm Groove couplings and fittings are identified by the nominal pipe diameter (DN) specified in millimetres or inches. The actual outside diameter (OD*) of the pipe and the couplings connected to it must always be checked, as it is customary in some markets to relate different pipe diameters to the same nominal dimension.

Roll groove profile

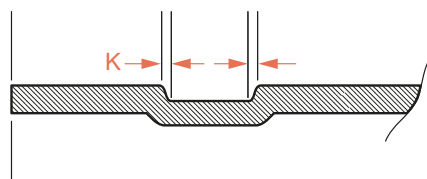

Grooves made by rolling should be defined as clearly as possible. To obtain the optimal coupling performance, "K" dimension should be as small as possible. During the grooving process, the machine operator should set the feed force of the upper roll set to obtain the best possible groove profile.

Applicable pipe wall thickness

Grooving by rolling is performed in the case of carbon steel pipes, stainless steel pipes, copper pipes and aluminium pipes with wall thickness of 9,5 mm or thinner, depending on the type of grooving machine and the used set of rollers. Different wall thickness and dimensions require the use of different sets of rollers. For additional information, contact the manufacturer of the groove rolling machine.

* Outside Diameter

Thick-walled pipes

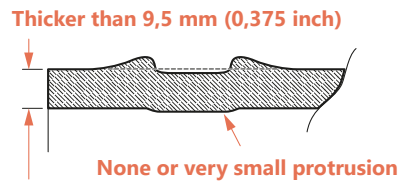

During attempt to make grooves (by rolling) on a pipe with a wall thicker than 9,5 mm, the metal may be deformed and swelled on both sides of the groove, instead of radially changing the shape and forming a protrusion towards the inside of the pipe. Additional metal swelling can lead to a coupling defect. In this case, the swollen metal layer should be grinded off to obtain a flat and smooth surface being in favour of effective sealing. The surface must be coated with antirust layer. In the case of thick-walled pipes, it is strongly recommended to use the grooving process by the cutting method.

Plain-end and bevelled end pipes

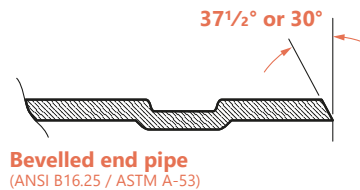

Although pipes with plain-ends are preferred, the use of a bevelled pipe is permissible provided that the wall thickness is 9.5 mm or less and the bevel is $37\frac{1}{2} \pm 2\frac{1}{2}^\circ$ or 30° , according to ANSI B16.25 and ASTM A-53.

Removing welding beads

Depending on the particular pipe and manufacturer, welding beads may remain on the surface of the pipe (internally and externally). Always remove harmful welding beads near the pipe ends, as they may cause uneven operation of the grooving machine, resulting in inaccurate grooves.

Galvanized pipes

Galvanized pipes are acceptable, provided that the surface of the gasket seat is smooth and free from scale or defects that could affect the quality of the seal. Each time after removing welding beads or protrusions from the surface of the galvanized pipe, care should be taken to avoid excessive grinding of the surface. After grinding the surface should always be covered with applicable anti-corrosion coating.

Spirally welded pipes

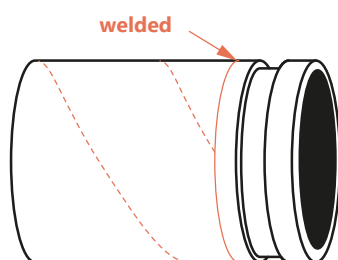

spiral pipe for groove joints

Spirally welded pipes are acceptable as long as the welding beads have been removed from the gasket placement surface. It is also permissible and recommended to weld a grooved part with the coupling to the pipe end. Each time after removing welding beads from the surface of the gasket seat, care should be taken to avoid excessive grinding of the surface. After grinding the surface should always be covered with anti-corrosion coating.

2.6.2 Checking the diameter of outer pipe

It must be ensured that the prepared pipe has an outside diameter (OD) and wall thickness applicable for the application. Due to the fact that the KAN-therm Groove couplings are usually identified according to the nominal dimension, the actual outer diameter (OD) of the pipe and the couplings connected to it must always be checked, as it is customary in some markets to relate different pipe diameters to the same nominal dimension.

For example: According to the IPS standard, the nominal dimension DN65 (2½") refers to a pipe with outer diameter of 73,0 mm, while according to the standards EN, AS, BS, DIN (ISO), JIS and KS the external diameter of the pipe for the same nominal dimension is 76,1 mm.

EN – European standard (metric system)

ISO – ISO standard (metric system)

BS – British standard (metric system)

DIN – German standard (metric system)

IPS – American standard (metric system)

Pipe dimension equivalents

Dimension in inches		Dimension in millimetres	
Nominal	Actual	Nominal	Actual
½	0,840	DN15	21,3
¾	1,050	DN20	26,7
1	1,315	DN25	33,7
1 ¼	1,660	DN32	42,4
1 ½	1,900	DN40	48,3
2	2,375	DN50	60,3
2 ½	2,875	-	73,0
3 OD	3,000	DN65	76,1
3	3,500	DN80	88,9
3 ½	4,000	-	101,6
4 ¼ OD	4,250	-	108,0
4	4,500	DN100	114,3
5	5,563	-	141,3
5 ¼ OD	5,250	-	133,0
5 ½ OD	5,500	DN125	139,7
6 ¼ OD	6,250	-	159,0
6	6,625	DN150	168,3
8	8,625	DN200	219,1
10	10,750	DN250	273,0
12	12,750	DN300	323,9

Which pipe can be grooved by rolling and which by cutting?

KAN-therm Groove couplings require grooving of joined pipe ends by cutting or rolling. The dimensions and configurations of the groove may vary depending on several factors, including the material of the pipe; wall thickness and required operating pressure.

Grooving by rolling is the practice most commonly used and can be carried out in a production workshop, in the field or on the construction site.

On the other hand, grooving by cutting takes place mainly in the factory or workshop because the grooving machines are not as common or mobile as the machines for grooving by rolling.

All grooves (both rolled and cut) must meet the ANSI/AWWA C606 (latest version) and ISO/FDIS 6182-12 standards. For other pipe dimensions not specified in ANSI/AWWA C606 (latest version) and ISO/FDIS 6182-12, please refer to the respective groove specifications in this manual. In the pipe grooving process, it is recommended to start with a smooth end pipe, although in some cases it is permissible to use a bevelled pipe, provided that the wall thickness is standard or smaller and the slant is $37\ 1/2^\circ \pm 2\ 1/2^\circ$ (ANSI B16.25).

Applications of rolled and cut grooves

Pipe material	Rolled groove	Cut groove
Carbon steel pipe	Standard wall, Series of types 40 (10" and less), 30, 20, 10, 7, 5, BS1387 medium and light, JIS SGP	Series of types 80, 40, 30 BS1387 medium and heavy, JIS SGP
Stainless steel pipe	Series of types 40S, 20S, 10S, 5S	Series of types 80S, 40S

Grooving by rolling

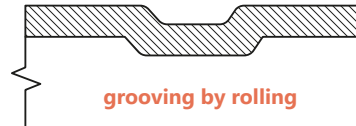

Grooving by rolling was used for the first time in the case of a light and thin pipe, the wall thickness of which was insufficient to apply the cutting method. Today, grooving by rolling is commonly used for standard pipes of series of schedule 40 (max. 9.5 mm wall thickness) up to 42 inches (DN1050) depending on the type of grooving machine and the set of rolls used.

Roll grooving radially displaces the pipe material. Because roll grooving removes no material from the pipe itself, the integrity of the pipe remains intact when properly grooved. The inside protrusion or upset of roll groove is small and smooth at its entry and exit and thus has insignificant or negligible effect on both flow and/or line pressure. Roll grooving is limited to pipe having a hardness of HB180 or less.

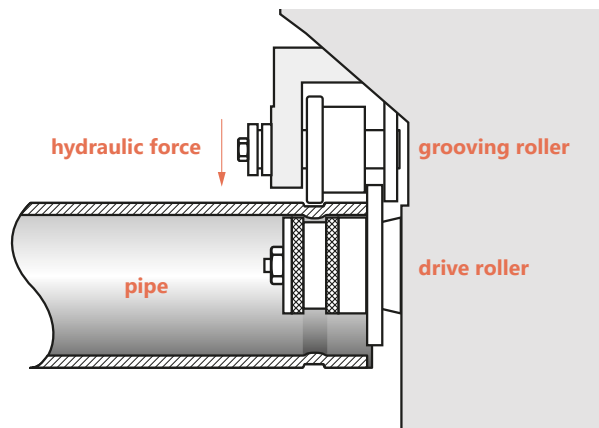

In the pipe grooving process, its end is placed between a set of rollers. When the rollers are tightened and rotated, a groove is formed from the outside and uplifted towards the inside of the pipe. Grooving by rolling can be used on carbon steel, stainless steel, copper and aluminum pipes. Care should be taken to use the right equipment and roller sets suitable for grooving specified material. Different materials may require different set of rollers, such as for copper, stainless steel or thick (9.5 mm) carbon steel pipes. For more information, refer to the grooving machine/rolling set manual.

Grooving by machining

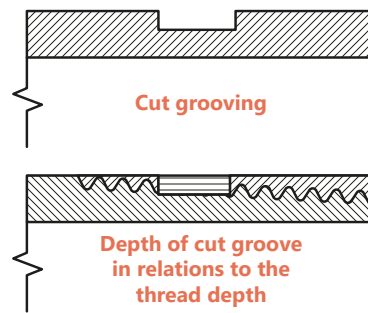

In the process of grooving by cutting, material from the outer diameter of the pipe is physically removed to form a groove. Therefore, this type of grooving is usually used for pipes with standard or heavy wall thickness. Most of the tubes designed for threading can be subjected to the grooving process, as the depth of the cut groove is usually smaller than the depth of the standard thread. Please refer to the values of the minimum wall thickness indicated in the table of standard parameters for cut grooves.

Contrary to grooving by rolling, grooving by cut causes grooving a rectangular slot in the pipe of without a protrusion on the inside of the pipe. Incision of grooves is widely used on pipeline elements such as 90° elbows, tees, grooved end valves, etc. It is also common practice to coat a grooved pipe with a plastic coating or cement cladding, as grooving by rolling can damage internal coating or pipe linings.

2.6.3 General remarks on the dimension of rolled and cut grooves

Nominal dimension

KAN-therm Groove couplings and fittings are identified by pipe nominal dimension, in inches, or nominal outside diameter of the pipe, given in millimetres.

External diameter: Pipe ends must be cut square

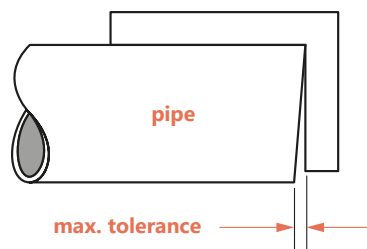

Maximum permissible tolerances for ends cut at right angle:

0,8 mm for diameter up to 3 1/2" (DN90),

1,2 mm for 4" to 6" (DN100-150)

1,6 mm up to 8" (DN200) and higher.

Standard dimensions of the rolled grooves

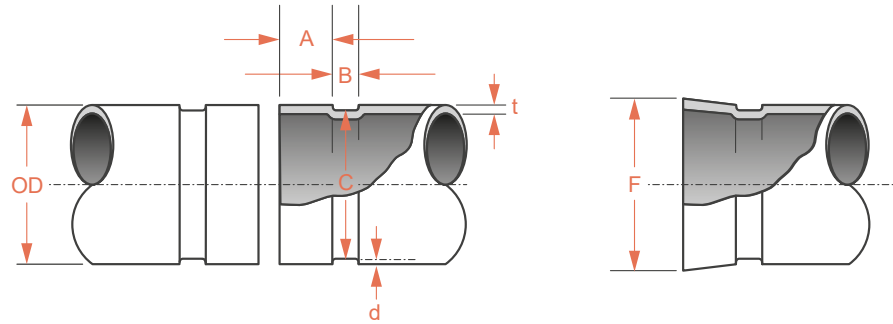

Surface of the gasket seat (dimension „A”)

The exterior surface of the gasket seating area shall be free from any indentations, projections, roll marks or other harmful surface defects such as loose paint, scale, dirt, chips, grease and rust.

Groove width (dimension „B”)

Width of the groove is measured between the vertical sides of the groove walls and results from the width pressed to the upper roller tube. The groove in the pipe should be visually inspected to ensure that it has distinct edges for effective wedging of the coupling. If the edges appear to be rounded and their lips are not vertical enough, the pipe should be replaced, as this situation can lead to a reduction in the tightness of the joint or a joint defect.

Groove diameter (dimension „C”)

Groove diameters are average values. The groove must have uniform depth around the entire circumference of the pipe.

Minimal wall thickness (dimension „t”)

Dimension “t” corresponds to the minimum permissible wall thickness which can be subjected to grooving by rolling.

Groove depth (dimension „d”)

The values listed in the parameter tables for grooves are for guidance only.

Diameter flare (dimension „F”)

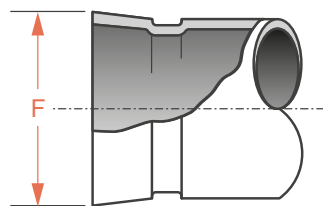

The diameter of the pipe end, which may expand during rolling, should be within the specified tolerance at the extreme end of the pipe.

Parameters for rolled grooves

Pipe or pipe duct			Dimensional specifications						
Nominal dimension	Outside Diameter (OD)		Gasket seat A $\pm 0,76$ A $\pm 0,76$	Groove width B $\pm 0,76$	Diameter after rolling C		Groove depth d (ref.)	Wall thickness t min.	Conicity F Max. Actual di- diam.
	Actual dimension	Tolerance			Actual dimension	Tolerance			
25	33,7	+0,41/-0,68	15,88	7,14	30,23	0/-0,38	1,70	1,8	34,5
32	42,4	+0,50/-0,60	15,88	7,14	38,99	0/-0,38	1,70	1,8	43,3
40	48,3	+0,44/-0,52	15,88	7,14	45,09	0/-0,38	1,60	1,8	49,4
50	60,3	$\pm 0,61$	15,88	8,74	57,15	0/-0,38	1,60	1,8	62,2
65	73	$\pm 0,74$	15,88	8,74	69,09	0/-0,46	1,98	2,3	75,2
65	76,1	$\pm 0,76$	15,88	8,74	72,26	0/-0,46	1,93	2,3	77,7
80	88,9	+0,89/-0,79	15,88	8,74	84,94	0/-0,46	1,98	2,3	90,6
90	101,6	+1,02/-0,79	15,88	8,74	97,38	0/-0,51	2,11	2,3	103,4
100	108	+1,07/-0,79	15,88	8,74	103,73	0/-0,51	2,11	2,3	109,7
100	114,3	+1,14/-0,79	15,88	8,74	110,08	0/-0,51	2,11	2,3	116,2
125	133,9	+1,32/-0,79	15,88	8,74	129,13	0/-0,51	1,93	2,9	134,9
125	139,7	+1,40/-0,79	15,88	8,74	135,48	0/-0,56	2,11	2,9	141,7
125	141,3	+1,42/-0,79	15,88	8,74	137,03	0/-0,56	2,13	2,9	143,5
150	159	+1,60/-0,79	15,88	8,74	154,50	0/-0,56	2,20	2,9	161,0
150	168,3	+1,60/-0,79	15,88	8,74	163,96	0/-0,56	2,16	2,9	170,7
200	219,1	+1,60/-0,79	19,05	11,91	214,40	0/-0,64	2,34	2,9	221,5
250	277,4	+1,60/-0,79	19,05	11,91	268,28	0/-0,69	2,39	3,6	275,4
300	328,2	+1,60/-0,79	19,05	11,91	318,29	0/-0,76	2,77	4,0	326,2

1. Outer diameter of the pipe Maximum permissible tolerances for cut ends at right angles is 0.03" for diameters not exceeding 3 1/2"; 0.045" for 4" to 6"; and 0.060" for diameters 8" and larger.
2. The surface of the gasket seat „A" should be free from deep scratches, spots and irregularities that would prevent effective sealing.
3. Dimensions "C" are average values. The groove must have the same depth around the entire circumference. To check the diameter of the groove, slide calliper or ruler should be used.
4. Dimension „t" corresponds to the minimum permissible wall thickness which can be subjected to grooving by rolling.
5. Value "d" is for guidance only. Groove depth must be specified using the groove diameter dimension „C".
6. Diameter flare: The diameter of the pipe end, which may expand during rolling, should be within this value at the extreme end of the pipe.

Parameters for cutted grooves

Pipe or pipe duct			Dimensional specifications					
Nominal dimension	Outside Diameter (OD)		Gasket seat A ± 0.031 A ± 0.79	Groove width B ± 0.031 B ± 0.79	Diameter after machining C		Groove depth d (ref.)	Wall thickness t min.
	Actual dimension	Tolerance			Actual dimension	Tolerance		
25	33,4	+0,33/-0,33	15,88	7,95	30,23	0/-0,38	1,60	3,38
32	42,2	+0,41/-0,41	15,88	7,95	38,99	0/-0,38	1,60	3,56
40	48,3	+0,48/-0,48	15,88	7,95	45,09	0/-0,38	1,60	3,68
50	60,3	+0,61/-0,61	15,88	7,95	57,15	0/-0,38	1,60	3,91
65	73,0	+0,74/-0,74	15,88	7,95	69,09	0/-0,46	1,98	4,78
80	88,9	+0,89/-0,79	15,88	7,95	84,94	0/-0,46	1,98	4,78
100	108,0	+1,04/-0,79	15,88	9,53	103,73	0/-0,51	2,11	5,16
100	114,3	+1,14/-0,79	15,88	9,53	110,08	0/-0,51	2,11	5,16
125	141,3	+1,42/-0,79	15,88	9,53	137,03	0/-0,56	2,11	5,16
150	168,3	+1,60/-0,79	15,88	9,53	163,96	0/-0,56	2,16	5,56
200	219,1	+1,60/-0,79	19,05	11,13	214,40	0/-0,64	2,34	6,05
250	273,0	+1,60/-0,79	19,05	12,70	268,27	0/-0,69	2,39	6,35
300	323,9	+1,60/-0,79	19,05	12,70	318,29	0/-0,76	2,77	7,09

1. Outer diameter of the pipe Maximum permissible tolerances for cut ends at right angles is 0.03" for diameters not exceeding 3 1/2"; 0.045" for 4" to 6"; and 0.060" for diameters 8" and larger.
2. The surface of the gasket seat „A" should be free from deep scratches, spots and irregularities that would prevent effective sealing.
3. Dimensions "C" are average values. The groove must have the same depth around the entire circumference. To check the diameter of the groove, slide calliper or ruler should be used.
4. Dimension „t" corresponds to the minimum permissible wall thickness which can be subjected to grooving by cutting.
5. Value "d" is for guidance only. Groove depth must be specified using the groove diameter dimension „C".

2.6.4 Bolts and nuts - tightening torque and assembly

Information useful for correct assembly

Some connectors and components require the housing bolt pads to allow metal parts to come in contact with each other, while others require a specific tightening torque to maintain the same spacing between the bolts. The following icons and information will be useful in identifying this type of elements and will help to ensure correct assembly. The assembly instructions for each installed component should be read and followed.



Metal-to-metal contact Tighten the bolts and nuts so that the clamps are tight against each other (metal-to-metal contact). After the contact of the metal surfaces of the clamp, the nuts should be tightened by a quarter or half turn to ensure that the bolts and nuts adhere tightly to the fastening element. A torque wrench is not required. Too high tightening torque can damage the bolts or coupling.

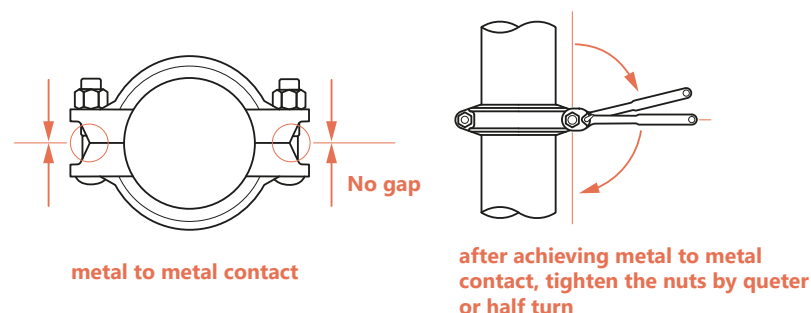

If after the assembly the gaps between the elements of the clamp hinge are visible, the coupling must be removed and reassembled, making sure in advance that:

- The connected coupling, pipe and/or fitting are of correct dimension.
- The coupling keys are completely interlocked in the pipe grooves and/or the component grooves.
- The gasket is not pinched.
- The grooves are in accordance with the applicable dimensional specification.
- The flare of the pipe end is within the tolerance range.



Tightening torque required!

The bolts and nuts should always be tightened to the required tightening torque with a torque wrench. Usually, after tightening the bolts and nuts, gaps will be visible between the pads of the clamp. Models requiring the use of tightening torque include all dimensions in the case of couplings and saddles of type 79.

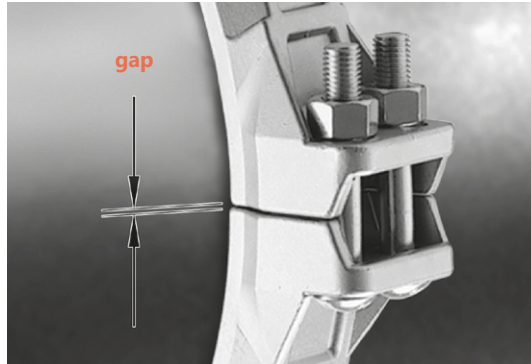

Recommended bolt torque



always use a torque wrench

Always use factory supplied bolts and nuts for the assembly of KAN-therm Groove couplings. General recommended torque ranges for typical dimensions of carbon steel bolts are presentend in table below. Never exceed the recommended torque range by more than 25%, as excessive tightening torque can lead to damage of the coupling, personal injury and/or property damage. Before disassembly, adjusting or removing any piping element, always depressurize and drain the piping system. In order to execute the installation consisting of KAN-therm Groove components properly, follow the installation instructions.

Tightening torque specifications

Bolt dimension		Tightening torque range Nm	
mm	inches	Lbs-Ft	Nm
M8	5/16" – 18	15 – 25	20 – 34
M10	3/8" – 16	30 – 40	40 – 55
M12	1/2" – 13	90 – 105	120 – 140
M16	5/8" – 11	100 – 130	135 – 175
M20	3/4" – 10	150 – 200	200 – 270
M22	7/8" – 9	180 – 220	240 – 300
M24	1" – 8	200 – 225	270 – 305
M29	1 1/8" – 7	250 – 300	340 – 400
M32	1 1/4" – 7	375 – 500	510 – 680

For stainless steel bolts the tightening torque is reduced by 20%

2.7 Installation guidelines

When installing the KAN-therm Groove system, always make sure that the right protective equipment at the installation site is used. The minimum protective equipment during the installation of the system are safety shoes, helmet and glasses.

2.7.1 General installation steps for grooved couplings assembly

Below is a list of the steps to be taken during assembly of the grooved couplings. If additional activities are required for some models, they can be found in the relevant chapters.



Check and prepare the ends of the pipes: To obtain optimal quality of sealing, the outer layer of pipe ends should be free of any dents, protrusions, rolling marks and other surface defects such as loosely adhering paint, scale, dust, chips, grease or rust.



Check the gasket: Make sure that the gasket supplied is suitable for the intended use. The colour of the stripe determines the type of gasket.



Lubricate the gasket: To facilitate insertion of the pipe and installation of couplings without pinching effect, apply a thin layer of grease available in KAN-therm Groove's offer on the lip of the gasket and on the outer coating of the gasket. Other suitable lubricants may be used as long as they do not have properties that may damage the gasket.



Install the gasket: Install the gasket at one end of the pipe so that the end of the pipe is visible. No part of the gasket should overhang this end of the pipe.



Connect the second pipe: match the two ends of the pipes to be connected. Slide the gasket into the ends and centre it between the grooves of the joined pipes. No part of the gasket should enter the grooves of the pipes.



Install the coupling: Start the assembly with the separated housing parts of the coupling.



Mount both halves of the coupling: Mount both halves at the same time. Make sure that the coupling keys are engaged in the grooves.



Insert the bolts and put on the nuts: Insert all bolts and tighten the nuts manually. Make sure that the oval bolt head is locked in the bolt hole in the coupling casing.



Tighten the nuts: Tighten nuts alternately and equally until the bolt pads meet and make metal-to-metal contact. Tighten nuts by another one quarter to one half turn to make sure the bolts and nuts are snug and secure. The use of a torque wrench is not required.

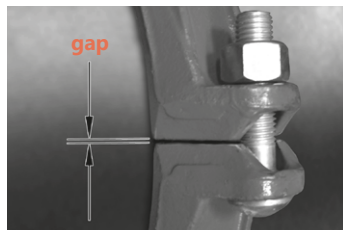

Tighten the nuts: Bolts and nuts must always be tightened to the required torque by using a torque wrench. Normally there will be gaps seen between the bolt pads after the bolts and nuts are fully tightened. Bolt pad gaps should be equal on both sides of the coupling.

- ⚠ **CAUTION!** Uneven tightening of the bolts and nuts may cause pinching of the gasket, causing immediate or later leakage. If a hammer wrench is used, excessive tightening of the nuts may damage the bolt or the coupling.
- ⚠ **NOTE!** Excessive tightening torque can cause the bolts and nuts to jam. To correct the problem with stainless steel bolts and nuts, Loctite C5-A anti-galling grease should be used. A good solution for preventing seizures is the use of silicon bronze nuts.

2.7.2 Installation of a rigid coupling with oblique bolt clamps Z05, Z07

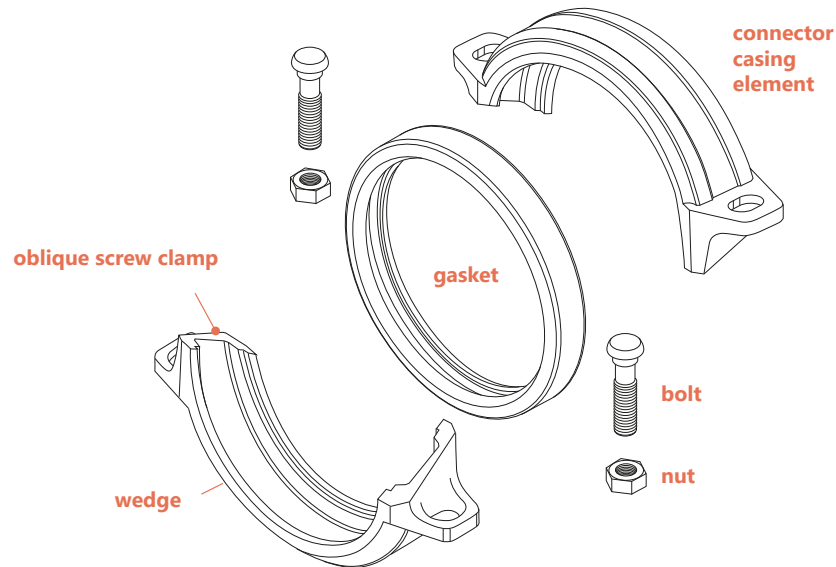

Please go to section 2.7.1 to remind the initial stages of assembly 1 – 8.



Tighten the nuts: Tighten the nuts alternately and with equal force until the projections of the clamp come into contact with each other (metal-to-metal contact). Tighten the nuts by a quarter or half turn to ensure that the bolts and nuts adhere tightly to the fastening element. The use of a torque wrench is not required.

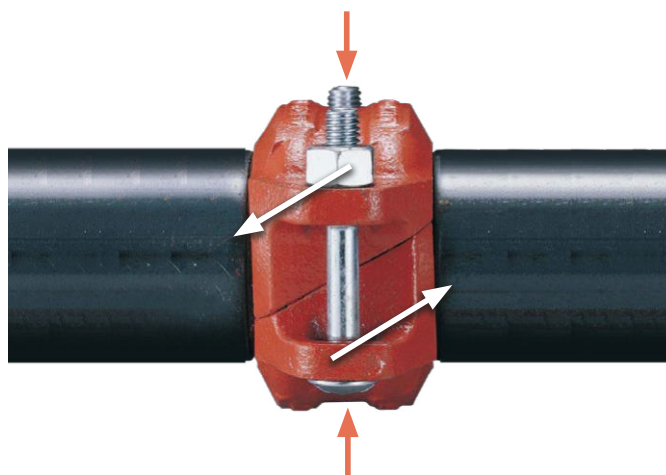

- ⚠ **NOTE!** After tightening the bolts of the coupling, the oblique bolt clamps move in the opposite directions, causing the wedges to be pressed against the surface of the pipe and making the grooves on the pipe pressed against the wedges of the coupling. Metal bolt clamps must always touch each other (metal-to-metal contact).

2.7.3 Installation of reducing coupling 7706

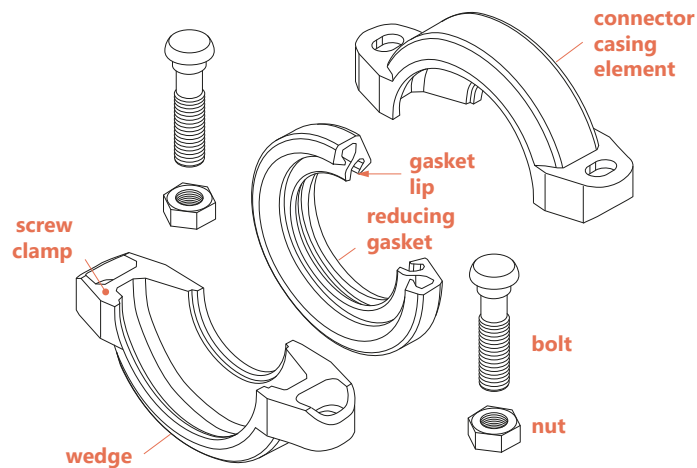

Please go to section 2.7.1 to remind the initial stages of assembly 1 – 3.

When assembling the reducing couplings, always install the gasket on the larger pipe. All other installation steps remain as described.



First, install the gasket on the larger pipe: Mount the larger opening of the gasket on the larger pipe end. The gasket should fit into but not over the groove in the larger pipe. A slight twisting motion on the pipe will help to seat the gasket on its surface.



Insert the smaller pipe: Bring together and align the two pipes to be mated and insert the smaller pipe into the gasket. A slight twisting motion on the pipe will make assembly easier.
Caution! Reducing couplings (such as model 7706) cannot be used with a plug as it can be sucked into the pipe when draining the piping system.

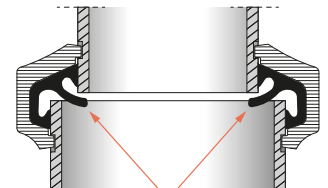

gasket lip

Note: To prevent the smaller pipe from cutting in, no washer is needed. The built-in blocking element (gasket lip) of the gasket helps to prevent the smaller pipe from cutting in. However, the smaller pipe should be inserted carefully and gently until the coupling casing is properly completed.



Tighten the nuts:

Tighten the nuts alternately and with equal force until the projections of the clamp come into contact with each other (metal-to-metal contact). Tighten the nuts by a quarter or half turn to ensure that the bolts and nuts adhere tightly to the fastening element. The use of a torque wrench is not required.

2.7.4 Installation of grooved flange adapters 7041

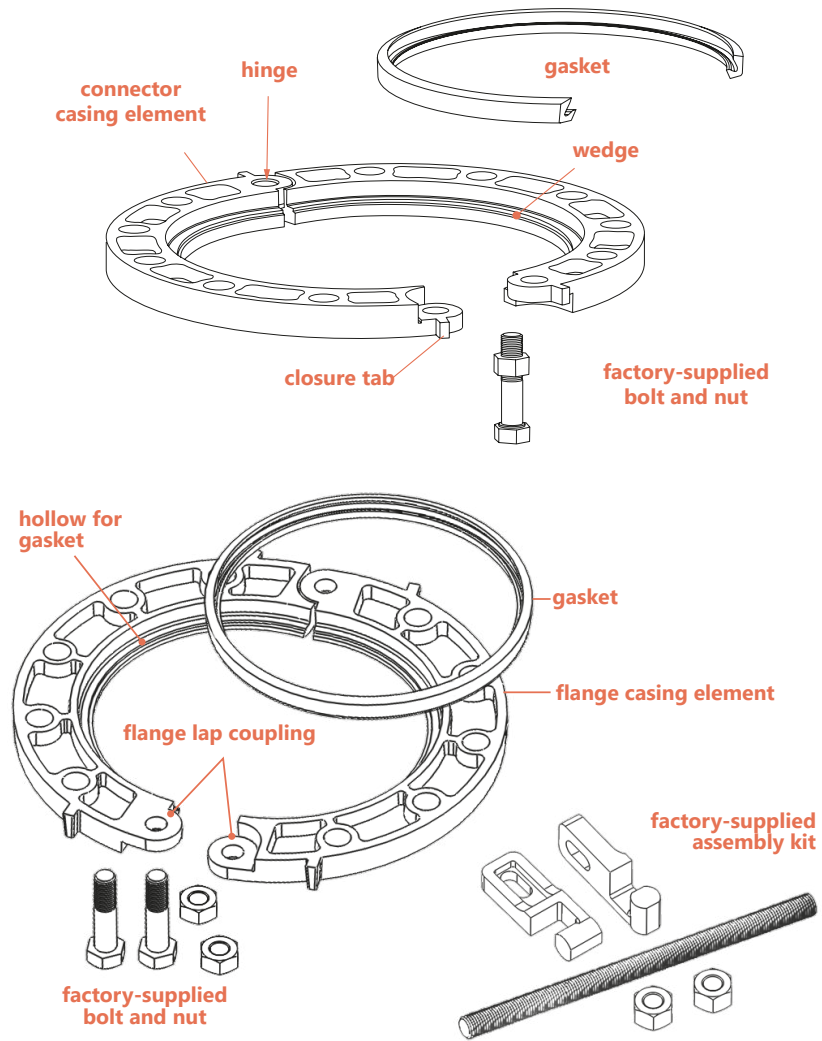

2.7.5 Bolts and nuts

KAN-therm Groove flange adapters comply with the PN10/16 standard, however, they are also available in accordance with ANSI standard class 125/150 and class 300.

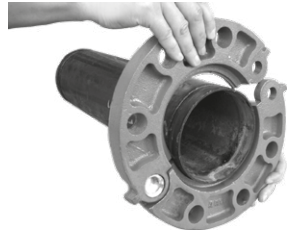

Install the articulated flange structure (2-12"): Open the articulated flange structure. Place the flange segments around the groove at the end of the pipe and tighten them together until the bolt holes are aligned.



Tighten the flange segments (2-12"): Use a wrench, clamp or other similar tool to tighten the locking projections until the bolt holes are aligned.

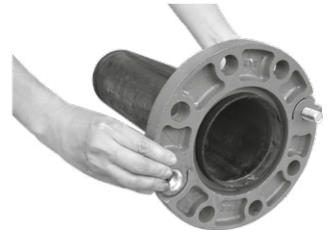

Insert the factory-supplied bolt (2-12"): Pass the factory-supplied bolt through the clamp hole, making sure that the flange completely adheres to the pipe grooves.

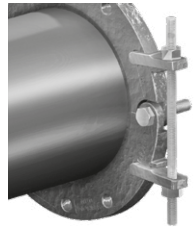

Insert the factory-supplied bolt (2-12"): Make sure that the flange is fully in contact with the pipe grooves.



Check the gasket grade and lubricate it: Check the colour of the gasket strip and make sure that the gasket supplied is suitable for the intended use. Then apply a thin layer of grease to the lip of the gasket.

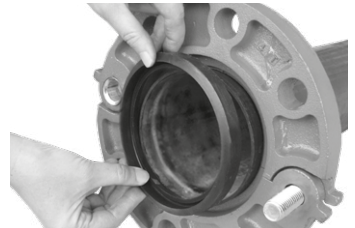

Install the gasket: Place the gasket in the recess between the outside diameter of the pipe and the recess in the flange. Make sure that the lower part of the gasket (marking side) is positioned and seated on the bottom of the gasket pocket.



Match the second flange: Insert the industrial bolt to fix the flanges to the hinge hole (opposite to the factory-supplied bolt) and tighten the nuts of the industrial bolt and the factory-supplied bolt.

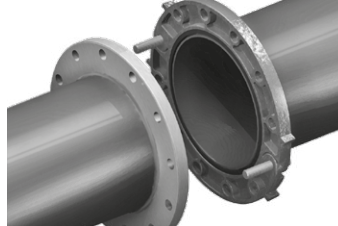

Match the second flange: Apply the matching flange surface to the surface of the flange adapter and thread the two factory-supplied bolts through the four holes in the flange couplings.

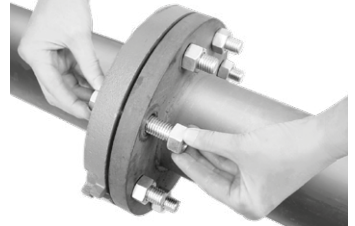

Add bolts: Insert the remaining industrial bolts and tighten the nuts manually. All bolts must be pointed in the same direction.

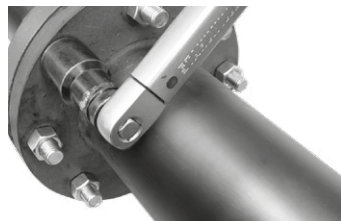

Tighten the nuts: Tighten the nuts alternately, diagonally. Bolts and nuts must always be tightened to the required torque by using a torque wrench.

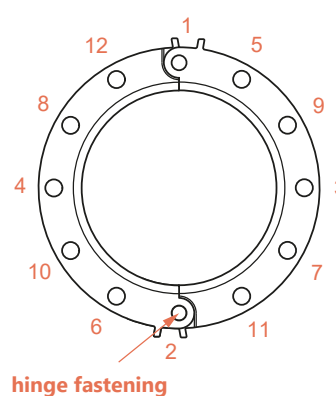
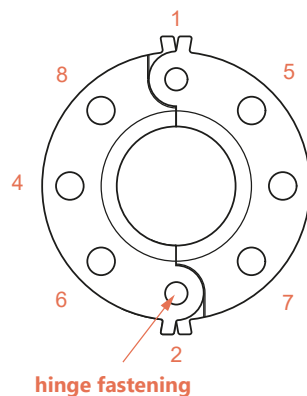

Required tightening torque

The tables below show standard values of the tightening torque for the correct installation of KAN-therm Groove flange adapters. Use a torque wrench so that all nuts are evenly tightened according to the same tightening torque value.

These tightening torque values are not maximum values and bolts can be tightened to values higher than specified. Obtaining the maximum tightening torque is not necessary because the KAN-therm Groove flange adapters are equipped with flexible (rubber) gaskets that require a much lower tightening torque than metal gaskets.

Model 7041 (ANSI CLASS 125/150) tightening torque requirements

Nominal dimension	Bolt dimension		Required tightening torque	
	inches	No.	Lbs-Ft	Nm
2	$\frac{3}{8}$	4	110–140	149–190
2 ½	$\frac{3}{8}$	4	110–140	149–190
3	$\frac{3}{8}$	4	110–140	149–190
4	$\frac{3}{8}$	8	110–140	149–190
5	$\frac{3}{4}$	8	220–250	298–339
6	$\frac{3}{4}$	8	220–250	298–339
8	$\frac{3}{4}$	8	220–250	298–339
10	$\frac{7}{8}$	12	320–400	434–542
12	$\frac{7}{8}$	12	320–400	434–542

Model 7041 (PN 10/16) tightening torque requirements

Nominal dimension	Bolt dimension		Required tightening torque	
	DN	No.	Lbs-Ft	Nm
50	M16	4	110–140	149–190
65	M16	4	110–140	149–190
80	M16	8	110–140	149–190
100	M16	8	110–140	149–190
125	M20	8	220–250	298–339
150	M20	8	220–250	298–339
200	M20	12	220–250	298–339
250	M24	12	320–400	434–542
300	M24	12	320–400	434–542

Installation of flat gasket in flange adapters 7041

Important remarks



- Flange adapters 7041 require a hard, flat surface that allows effective sealing. If the co-working surface is not suitable, as with the serrated surfaces of some valves or dampers with a rubberised surface, a flat gasket (Model 49) should be used.

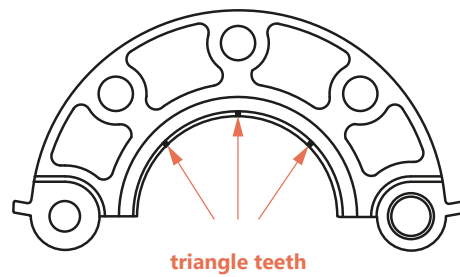
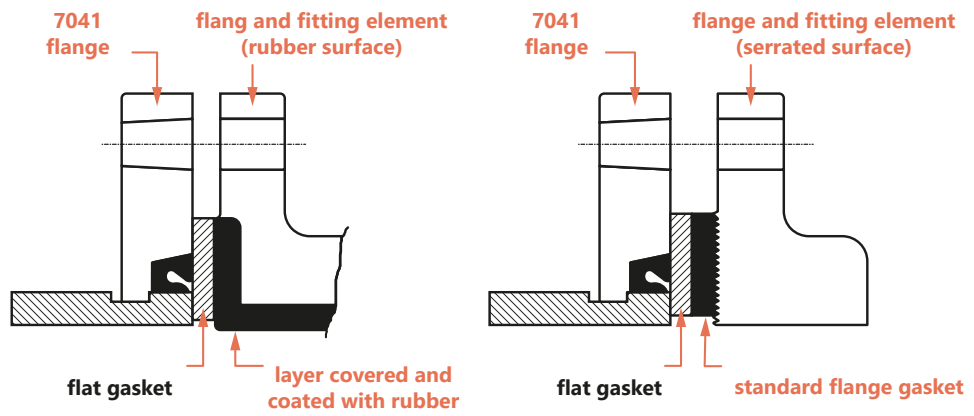

- Flange adapters 7041 have small triangular teeth inside the wedge arm to prevent the pipe from rotating. The teeth should be ground in the event of a connection with a flange with a rubber coating.
- Flange adapters 7041 cannot be used as anchor points for tendons on non-stretchable couplings.

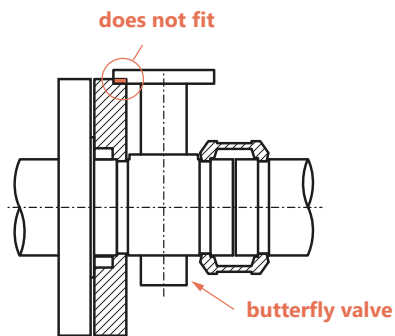

- When installing the flange adapter 7041 on the butterfly valve or ball valve, make sure that the outer diameter of the flange adapters does not interfere with the valve actuator or the actuator mounting washer.

2.7.6 Installation of saddle couplings

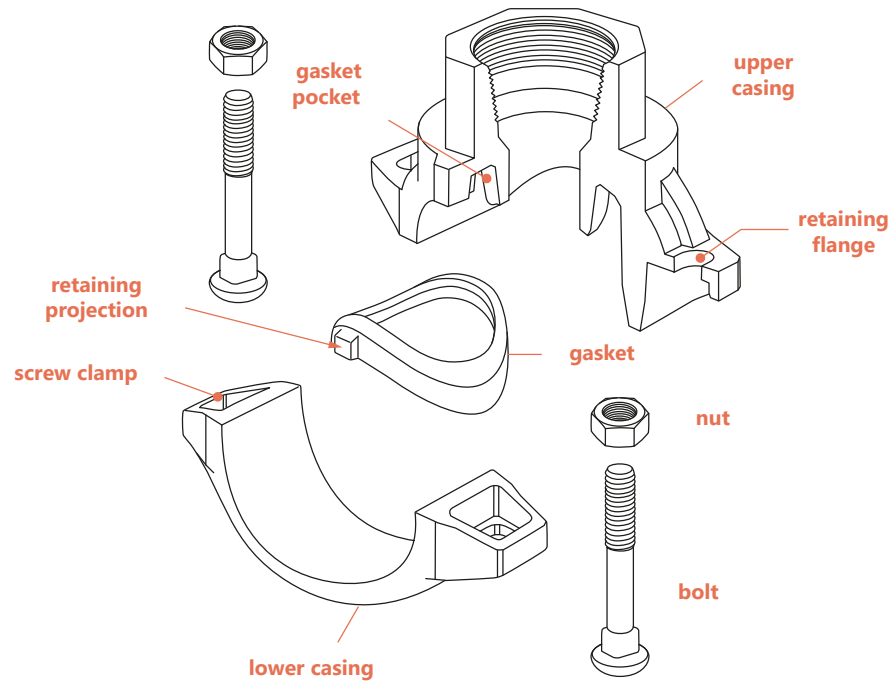

Saddle system

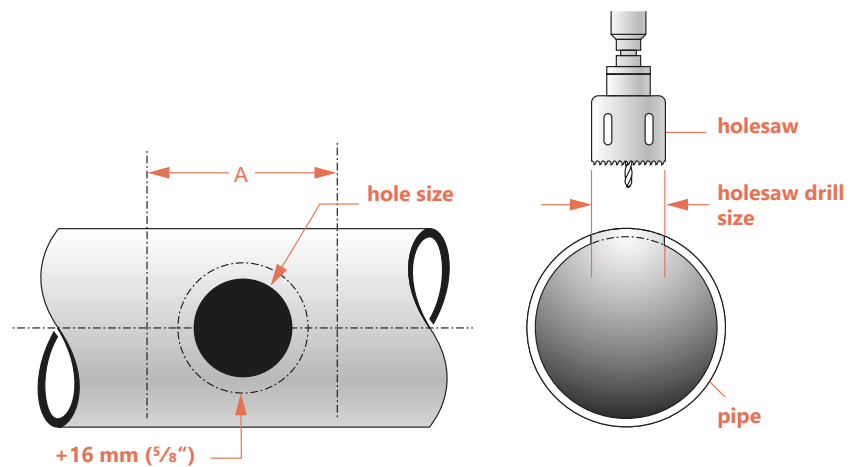

When installing saddle and cross type couplings, it is required to prepare the pipe by making the hole. This method of pipe preparation requires cutting or drilling a certain hole dimension in the pipe axis. Always use the right dimension keyhole saw as shown in this document.

! Caution! The hole must be cut to the end and should have a smooth edge. Never use a burner to drill the hole, as this can affect the quality of the seal.



Cutting the hole: Determine the position of the hole on the pipe. Use a suitable hole dimension drill saw, according to the table below regarding the required hole dimension.



Remove beads and rough edges

and clean the pipe surface within a radius of 16 mm around the hole in which the gasket is to be seated. This area should be checked to ensure a clean, smooth surface, with no recesses or protrusions that could affect the quality of the seal.

The area within the "A" dimension should also be checked for dirt, scale or any defects that could affect the effective seating of the gasket or the assembly of the coupling.

The dimensions of holes and area „A” for saddle coupling

Saddle-type coupling passage × branch		Hole dimensions				Preparation of "A" surface	
		Hole saw		Max. permissible diameter			
inches	mm	inches	mm	inches	mm	inches	mm
2 × ½	50 × 15	1 ½	38	1 ⅝	41	3 ½	89
2 × ¾	50 × 20	1 ½	38	1 ⅝	41	3 ½	89
2 × 1	50 × 25	1 ½	38	1 ⅝	41	3 ½	89
2 × 1 ¼	50 × 32	1 ¾*	45	1 7/8*	47	4	102
2 × 1 ½	50 × 40	1 ¾*	45	1 7/8*	47	4	102
2 ½ × ½	65 × 15	1 ½	38	1 ⅝	41	3 ½	89
2 ½ × ¾	65 × 20	1 ½	38	1 ⅝	41	3 ½	89
2 ½ × 1	65 × 25	1 ½	38	1 ⅝	41	3 ½	89
2 ½ × 1 ¼	65 × 32	2	51	2 ⅛	54	4	102
2 ½ × 1 ½	65 × 40	2	51	2 ⅛	54	4	102
3 × ½	80 × 15	1 ½	38	1 ⅝	41	3 ½	89
3 × ¾	80 × 20	1 ½	38	1 ⅝	41	3 ½	89
3 × 1	80 × 25	1 ½	38	1 ⅝	41	3 ½	89
3 × 1 ¼	80 × 32	2	51	2 ⅛	54	4	102
3 × 1 ½	80 × 40	2	51	2 ⅛	54	4	102
3 × 2	80 × 50	2 ½	64	2 ⅝	67	4 ½	114
4 × ½	100 × 15	1 ½	38	1 ⅝	41	3 ½	89
4 × ¾	100 × 20	1 ½	38	1 ⅝	41	3 ½	89
4 × 1	100 × 25	1 ½	38	1 ⅝	41	3 ½	89
4 × 1 ¼	100 × 32	2	51	2 ⅛	54	4	102
4 × 1 ½	100 × 40	2	51	2 ⅛	54	4	102
4 × 2	100 × 50	2 ½	64	2 ⅝	67	4 ½	114
4 × 2 ½	100 × 65	2 ¾	70	2 7/8	73	4 ¾	121
4 × 3	100 × 80	3 ½	89	3 ⅝	92	5 ½	140
5 × 2	125 × 50	2 ½	64	2 ⅝	67	4 ½	114
5 × 2 ½	125 × 65	2 ¾	70	2 7/8	73	4 ¾	121
6 × 1 ¼	150 × 32	2	51	2 ⅛	54	4	102
6 × 1 ½	150 × 40	2	51	2 ⅛	54	4	102
6 × 2	150 × 50	2 ½	64	2 ⅝	67	4 ½	114
6 × 2 ½	150 × 65	2 ¾	70	2 7/8	73	4 ¾	121
6 × 3	150 × 80	3 ½	89	3 ⅝	92	5 ½	140
6 × 4	150 × 100	4 ½	114	4 ⅝	118	6 ½	165
8 × 2	200 × 50	2 ¾*	70	2 7/8*	73	4 ¾	121
8 × 2 ½	200 × 65	2 ¾	70	2 7/8	73	4 ¾	121
8 × 3	200 × 80	3 ½	89	3 ⅝	92	5 ½	140
8 × 4	200 × 100	4 ½	114	4 ⅝	118	6 ½	165

***Important!** Pay special attention to the dimension of the hole saw drill and the maximum diameter allowed for a given dimension, any deflection can lead to coupling damage.

Specification of hole dimensions

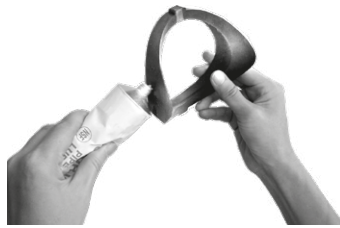

Check the gasket grade and lubricate it: Check the colour of the gasket strip and make sure that the gasket supplied is suitable for the intended use. Then apply a thin layer of grease to the lip of the gasket. The standard, factory-supplied gasket is made of a mix of E-class EPDM. It is marked with a green strip and is generally suitable for use in water pipelines.



Insert the gasket: Insert the gasket into the casing so that the gasket seat in the casing. The retaining projections on both sides of the gasket should properly fit into the recesses.



Prepare for assembly: Assemble the coupling casing loosely, leaving one bolt and nut disconnected to allow the hinge mechanism to be moved.

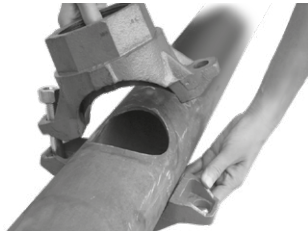

Position the upper casing in the correct position: Place the upper casing part on the pipe so that the retaining flange fits properly into the hole. Then add the lower casing part from the opposite side of the pipe.

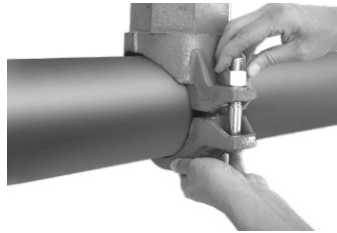

Insert the bolts and put on the nuts: Insert the remaining bolt and tighten the nut manually. Make sure that the oval bolt head is locked in the bolt hole in the coupling casing.



Check the retaining flange: Make sure that the retaining flange is properly seated in the hole. You can check this by swinging the top of the casing in the hole. Make sure also that the oval bolt head is locked in the bolt hole in the coupling casing.



Tighten the nuts: Tighten the nuts alternately and with equal force until the casing of the outlet come into contact with the outer surface of the pipe (metal-to-metal contact). Gaps between bolt clamps are acceptable but they should be the same on both sides. Use a torque wrench and tighten the nuts to get the correct tightening torque values.

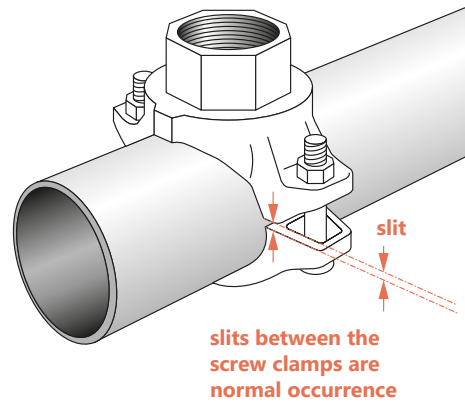

Saddle-type couplings – models 7721 and 7722

Nominal dimension		Bolt dimension		Required tightening torque	
inches	mm	inches	No.	lbs-Ft	Nm
2	50	$\frac{3}{8}$	2	30	40
2 ½	65	$\frac{1}{2}$	2		
3	80	$\frac{1}{2}$	2		
4	100	$\frac{1}{2}$	2	50	68
5	125	$\frac{3}{8}$	2		
6	150	$\frac{3}{8}$	2		
8	200	$\frac{3}{4}$	2		



Caution! Do not exceed the above tightening torque range by more than 25%, as excessive tightening torque can lead to damage of the bolt and/or the coupling.

Characteristics of the output flow

Outlet dimension		Equivalent length		Outlet dimension		Equivalent length	
inches	mm	7721	7722	inches	mm	7721	7722
		feet	feet			feet	feet
1	25	3	3	2 ½	65	15	15
1 ¼	32	6	6	3	80	16	16
1 ½	40	8	8*	4	100	17	17
2	50	9	9				

Values in feet and meters for a steel outlet pipe (series 40) with a coefficient of friction, calculated according to the Hazen-Williams formula, of 120.

* Equivalent length for models 7721 with 1 ½" outlet and 2 ½" course is 13 feet (4 meters)

2.7.7 Couplings for steel pipe systems with smooth ends

Installation of a Wildcat coupling (model 79) for connecting carbon steel pipes

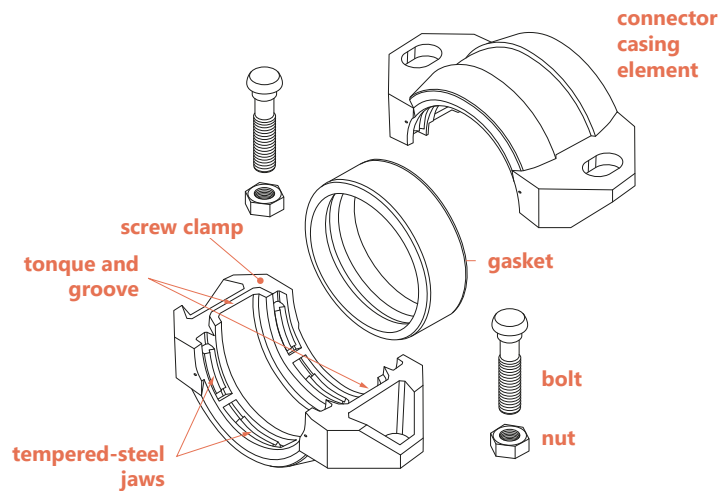

The KAN-therm Groove coupling with a smooth end of Wildcat type (model 79) has been designed for mechanical joining of carbon steel pipes with smooth ends or bevelled. Grooving is not required. The Wildcat coupling (model 79) is recommended for use on carbon steel pipes with hardness less than HB150. It is not recommended for use on stainless steel, plastic, HDPE, cast iron and other brittle materials.

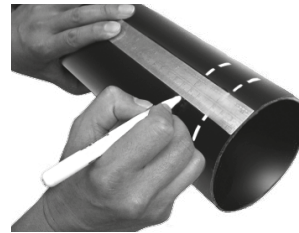
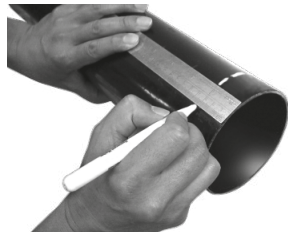

Marking: Use a pen or other marking tool and measuring tape to mark a distance of 1 inch from the end of the pipe. The marking will be used as a reference point when the seal is centred during the assembly. It is recommended to make a minimum of 4 markings spaced at the same intervals around the circumference of the pipe.

Use a measuring tape and a pen or other marking tool to make a second marking at the ends of the pipes according to the measurement values given in the table on page 161. This marking will be used during visual inspection to ensure that the pipe has been correctly placed in the coupling. Markers should run parallel to the reference marks for centring the gasket.

Check the gasket: Check the colour of the gasket strip and make sure it is suitable for the intended use. The standard, factory-supplied gasket is made of a mix of E-class EPDM. It is marked with a green strip and is generally suitable for use in water pipelines.



Lubricate the gasket: To facilitate insertion of the pipe and installation of coupling without pinching effect, apply a thin layer of KAN-therm grease on the lip of the gasket and on the outer coating of the gasket.

Other suitable lubricants may be used as long as they do not have properties that may damage the gasket. In systems exposed to extremely high or low temperatures, it is recommended to use a silicone grease.

Caution! Do not use gaskets made of EPDM in installations containing hydrocarbons or petroleum, as this may cause leakage or damage to the coupling.



Install the gasket: Place the gasket on the ends of the pipes and centre it between the first marks marked on the inside. The ends of the pipes should always come into contact.



Install casing elements: Place the casing components around the gasket, making sure that it is centred between the first marks drawn at the pipe ends on the inside and that the casing elements are centred between the second markings drawn on the outside. Make also sure that the feather and groove of the casing are aligned.

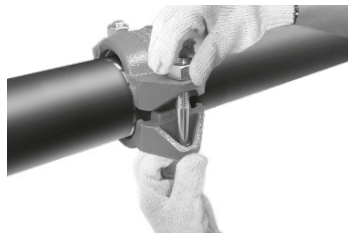

Insert the bolts and put on the nuts: Insert all bolts and tighten the nuts manually. Make sure that the oval bolt head is locked in the bolt hole in the coupling casing.



Tighten the nuts: Using a torque wrench, tighten the nuts alternately and with the same force until the desired tightening torque is reached. Insufficient tightening torque can lead to pipe separation, which can cause damage to the body and/or property. The required tightening torque values are given in the adjacent table.

Caution! To avoid injury caused by sharp edges of the teeth, always wear protective gloves when working.

Centring markings and minimum tightening torque required for the WILDCAT coupling (model 79)

Dimension		Marking for centring the coupling		Bolts of the coupling set			
inches	mm	inches	mm	Quantity	Bolt dimension in inches	Required tightening torque	
						Lbs-Ft	Nm
1	25	1,50	40	2	½ × 2 ¾	110	150
1 ½	40	1,50	40	2	½ × 2 ¾	110	150
2	50	1,75	45	2	¾ × 3 ½	150	200
2 ½	65	1,75	45	2	¾ × 3 ½	150	200
3	80	1,75	45	2	¾ × 4 ¾	200	270
4	100	2,00	50	2	¾ × 4 ¾	200	270
5	125	2,00	50	2	7/8 × 6 ½	250	340
6	150	2,25	55	2	7/8 × 6 ½	250	340
8	200	2,50	65	4	¾ × 4 ¾	200	270
10	250	2,50	65	4	7/8 × 6 ½	300	400
12	300	2,50	65	4	1 × 6 ½	350	470
14	350	2,75	70	4	1 × 6 ½	350	470
16	400	2,75	70	4	1 × 6 ½	350	470



Caution!

- Uneven tightening of the bolts and nuts may cause pinching of the gasket, causing immediate or later leakage.
- Too high tightening torque can damage the bolts or coupling.

2.7.8 Couplings for plain-end HDPE piping systems

The KAN-therm Groove HDPE series has been designed to provide a fast and easy way to mechanically join HDPE (high density polyethylene) pipes. KAN-therm Groove HDPE couplings are intended to join HDPE pipes and fittings conforming to ISO 161/1, DIN 8074 and AS 8074, with SDR from 32,5 to 7,3. The connection method eliminates the need for costly heat fusion equipment, gluing or using complicated adapters.

The maximum working pressure at which KAN-therm Groove HDPE couplings can operate is limited by the strength of the HDPE pipes used.

HDPE pipes

The following table shows the permissible dimensional tolerances of HDPE rigid pipe with SDR 20, at ambient temperature of +21 °C.

Pipe size/tolerance – metric sizes (DIN and others)

Pipe O.D. min.	Pipe O.D. max.*
mm	mm
50	50,5
63	63,6
75	75,7
90	90,9
110	111,0
160	161,5
180	181,7
200	201,8
225	226,4
250	252,3
280	281,7
315	317,9
355	357,2
400	402,4
450	452,7
500	504,0

* tolerances at ambient temperature for pipes with SDR 20 or lower

! **Note! KAN-therm HDPE series couplings are not intended for use with PVC or other materials.**

Installation of H305 coupling for connecting HDPE pipes

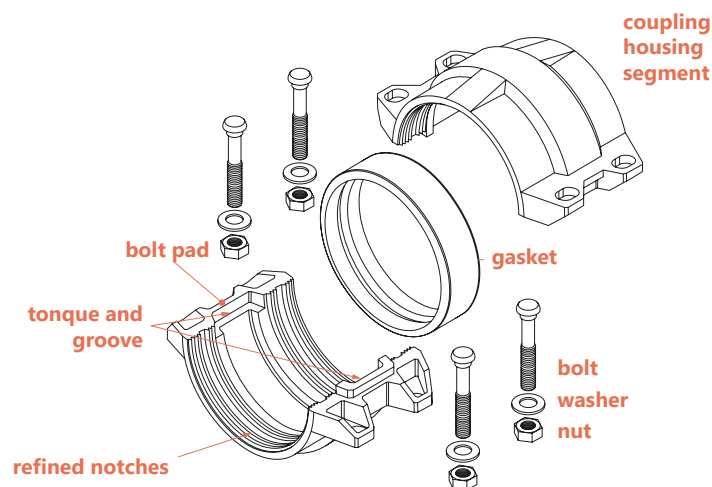

The KAN-therm H305 HDPE coupling is equipped with four bolt holes and a series of sharply refined notches which ensure a solid grip during tightening couplings bolts and nuts.

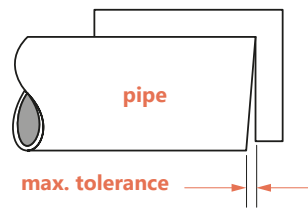

Cut pipe perpendicularly to the axis:

HDPE pipe must be cut square. Maximum permissible tolerances for ends cut at right angle: 1/8" (3,2 mm) for HDPE pipe for diameter 2" up to 4" and 3/32 (4,0 mm) for 6" or higher. Make sure that end of the pipe, within 1" from the edge is clean and free of indentations, burrs, scratches or other harmful surface defects.



Check the gasket grade: Check the colour of the gasket strip and make sure that the gasket supplied is suitable for the intended use. The standard, factory-supplied gasket is made of a mix of E-class EPDM. It is marked with a green strip and is generally suitable for use in water pipelines.

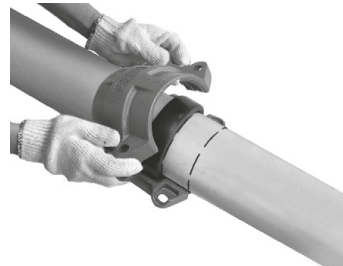

Install casing elements: Place the casing components around the gasket, making sure that it is centred between the first marks drawn at the pipe ends on the inside and that the casing elements are centred between the second markings drawn on the outside. Make also sure that the feather and groove of the casing are aligned.

Caution! To avoid injury caused by sharp edges of the teeth, always wear protective gloves when working.



Marking: Use a marking pen or other marking tool and measuring tape to mark the appropriate distance from pipe end according to the table. The marking will be used as a reference point when the seal is centred during the assembly. It is recommended to make a minimum of 4 markings spaced at the same intervals around the circumference of the pipe.



Install the gasket: Place the gasket on the ends of the pipes and centre it between the first marks marked on the inside. The ends of the pipes should always come into contact.



Use a measuring tape and a pen or other marking tool to make a second marking at the ends of the pipes according to the measurement values given in the table. This marking will be used during visual inspection to ensure that the pipe has been correctly placed in the coupling. Markers should run parallel to the reference marks for centring the gasket.

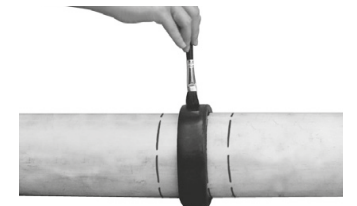

Lubricate the gasket: Apply a thin layer of silicone grease on the lip of the gasket and on the outer coating of the gasket. Other lubricants based on silicone, corn oil, soybean oil or glycerine, suitable for HDPE systems, can also be used.

Note: The use of oils, hydrocarbon-based lubricants and soaps is prohibited.



Insert the bolts and put on the nuts: Insert all bolts and pads and tighten the nuts manually. Make sure that the oval bolt head is locked in the bolt hole in the coupling casing.

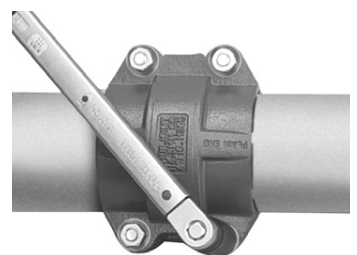

Tighten the nuts: Tighten nuts alternately and equally until the bolt pads meet and make metal-to-metal contact. Tighten nuts by another one quarter to one half turn to make sure the bolts and nuts are snug and secure. The use of a torque wrench is not required.

Note! Large Diameter H305 HDPE couplings: 14" (355,6 mm) and larger included hex bolts, washers and nuts. Refer to the below steps for the correct tightening technique.



Insert bolts and washers: Insert bolts and washers into specially prepared holes in the housings. Make sure that the each bolt head and washer are aligned with the recess in the housing.



Insert the nuts: Thread a nut onto the end of each bolt until the washer contacts the housing.



Tighten the nuts: Tighten nuts alternately and equally until the bolt pads meet and make metal-to-metal contact. Tighten the nuts by a quarter or half turn to ensure that the bolts and nuts adhere tightly to the fastening element. Make sure that the pads are located in the bolt hole in the coupling casing.

Table of markings for centering the gasket and coupling on pipe

External pipe diameter	Gasket centering reference mark	Coupling centering reference mark
mm	mm	mm
50	22	53
63	22	53
75	22	53
90	22	53
110	22	56
160	25	59
180	25	59
200	26	64
225	26	64
250	26	67
280	26	67
315	26	67
355	37	129
400	37	129
450	37	129
500	37	131

Caution!

- Uneven tightening of the bolts and nuts may cause pinching of the gasket, causing immediate or later leakage.
- Too high tightening torque can damage the bolts or coupling.

Installation of H307 HDPE transition coupling

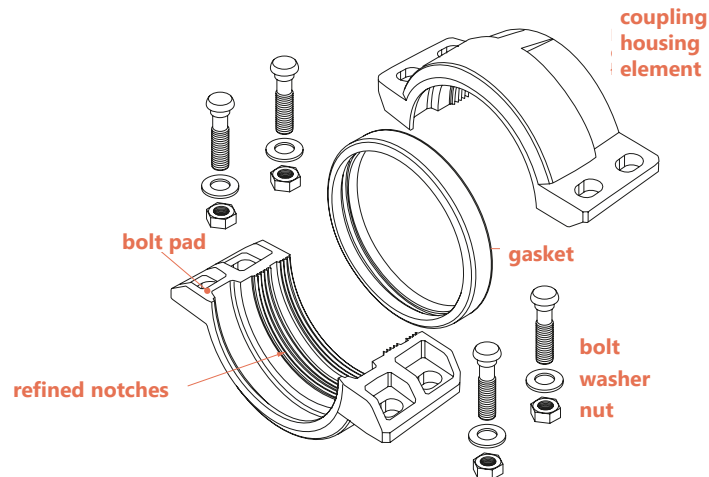

The KAN-therm Groove H307 HDPE transition coupling provides a direct transition from HDPE to steel pipe of the same outer diameter. The H307 transition coupling must be installed with the notched side on the HDPE pipe and the wedge section on the grooved steel pipe.

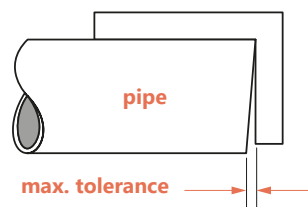

Cut pipe perpendicularly to the axis:

HDPE pipe must be cut square. Maximum permissible tolerances for ends cut at right angle: $\frac{1}{8}$ " (3,2 mm) for HDPE pipe for diameter 2" up to 4" and $\frac{3}{32}$ " (4,0 mm) for 6" or higher. Make sure that pipe end, within 1" from the end, is clean and free of dents, burrs, scratches or other harmful defects. The steel pipe end must be grooved acc. to KAN-therm Groove guidelines.



Marking: Use a marking pen or other marking tool and measuring tape to mark the appropriate distance from the HDPE pipe end, according to the values given in the table. The marking will be used as a reference point when the seal is centred during the assembly. It is recommended to make a minimum of 4 markings spaced at the same intervals around the circumference of the pipe.



Check the gasket grade: Check the colour of the gasket strip and make sure that the gasket supplied is suitable for the intended use. The standard, factory-supplied gasket is made of a mix of E-class EPDM. It is marked with a green strip and is generally suitable for use in water pipelines.

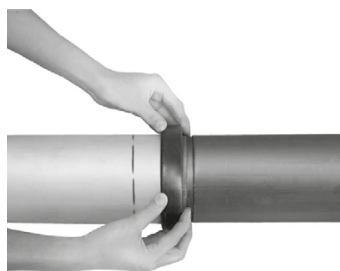

Install the gasket: Place the gasket on the pipe ends and centre it between the marks on HDPE pipe and the groove of the steel pipe. The pipe ends should be butted against each other or with a controlled distance - the maximum allowable distance between HDPE pipe and steel pipe is $\frac{1}{4}$ " (6,3 mm) for pipe diameters 2" to 4" and $\frac{3}{16}$ " (7,9 mm) for pipe diameters 6" and larger.

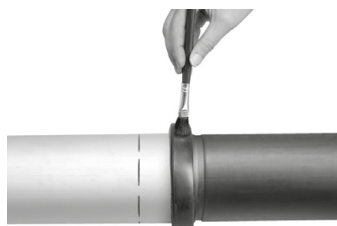

Lubricate the gasket: Apply a thin layer of silicone grease on the lip of the gasket and on the outer coating of the gasket. Other lubricants based on silicone, corn oil, soybean oil or glycerine, suitable for HDPE systems, can also be used. **Note:** The use of oils, hydrocarbon-based lubricants and soaps is prohibited.



Install casing elements: Place the housings over the gasket, making sure that the gasket is centred between the marks made on HDPE pipes end and the groove of the steel pipe.

Caution! To avoid injury caused by sharp edges of the teeth, always wear protective gloves when working.



Insert the bolts and put on the nuts: Insert all bolts and pads and tighten the nuts manually. Make sure that the oval bolt head is locked in the bolt hole in the coupling casing.



Tighten the nuts: Tighten nuts alternately and equally until the bolt pads meet and make metal-to-metal contact. Tighten nuts by another one quarter to one half turn to make sure the bolts and nuts are snug and secure. The use of a torque wrench is not required.

Table of markings for centering the gasket and coupling on pipe

External pipe diameter	Mark location from the HDPE pipe end
mm	mm
63	50
75	50
90	50
110	50
160	50
200	53
250	64
315	64



Caution!

- Uneven tightening of the bolts and nuts may cause pinching of the gasket, causing immediate or later leakage.
- Too high tightening torque can damage the bolts or coupling.

2.8 Design data - rigid and flexible couplings

Mechanical grooved couplings are available in both rigid and flexible forms.

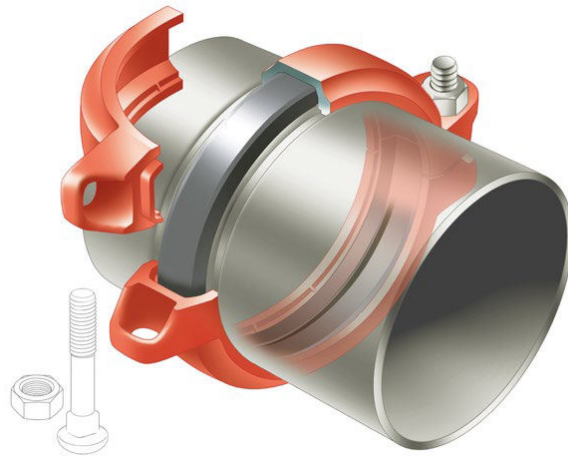

The rigid coupling is intended for uses where a rigid connection is required, similar to a traditional flange, welded or threaded connection. In order for the coupling to be considered rigid, its deflection rate or angular movement value must be less than one.

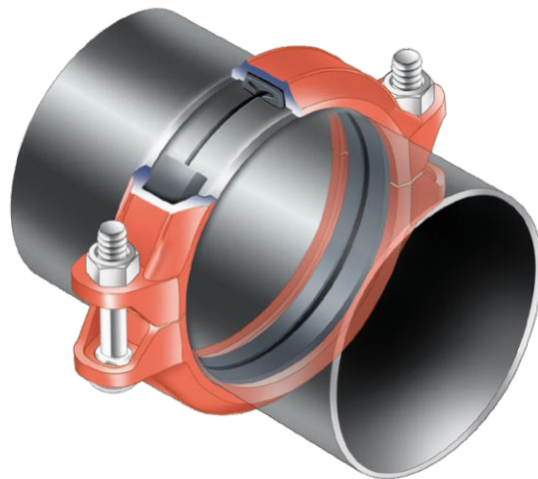

Flexible couplings are designed to adapt to axial movements, rotational movement and angular movement of a minimum of one degree. Flexible couplings are used in applications where pipework is a curved and deformed structure or in which pipeline systems are exposed to external forces beyond normal static conditions, such as seismic events or when there is a problem of excessive exposure to vibrations or noise.

Grooved couplings become less flexible when the dimension of the pipe increases. The following table contains design data on the permissible axial movement and angular deflection for flexible couplings.

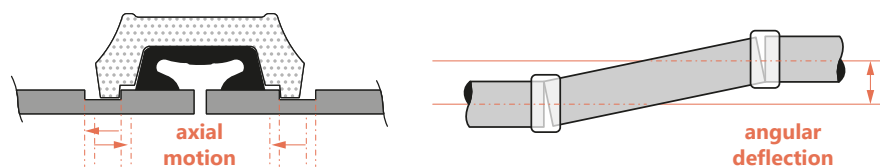

Design data of KAN-therm Groove flexible couplings - models 7705, 7707

Dimension			Rolled groove		Machined groove			
inches	DN	mm	Axial movement	Angle bend	mm/m	Axial movement	Angle bend	
			mm/ coupling	degrees		mm/ coupling	degrees	mm/m
1	25	33,4	0 – 0,8	1,37°	24	0 – 1,6	2,74°	48
1 ¼	32	42,2	0 – 0,8	1,09°	19	0 – 1,6	2,17°	38
1 ½	40	48,3	0 – 0,8	0,95°	16,5	0 – 1,6	1,90°	33
2	50	60,3	0 – 0,8	0,76°	13,5	0 – 1,6	1,52°	27
2 ½	-	73	0 – 0,8	0,63°	11	0 – 1,6	1,26°	22
-	65	76,1	0 – 0,8	0,60°	10,5	0 – 1,6	1,20°	21
3	80	88,9	0 – 0,8	0,52°	9	0 – 1,6	1,03°	18
		101,6	0 – 0,8	0,45°	8	0 – 1,6	0,90°	16
		108	0 – 2,4	1,27°	22,5	0 – 4,8	2,54°	45
4	100	114,3	0 – 2,4	1,20°	21	0 – 4,8	2,40°	42
	-	125	139,7	0 – 2,4	0,98°	17,25	0 – 4,8	1,97°
5	-	141,3	0 – 2,4	0,97°	17,25	0 – 4,8	1,95°	34,5
		159	0 – 2,4	0,86°	15	0 – 4,8	1,73°	30
6	150	168,3	0 – 2,4	0,82°	14,25	0 – 4,8	1,63°	28,5
8	200	219,1	0 – 2,4	0,63°	11,25	0 – 4,8	1,26°	22,5
10	250	273	0 – 2,4	0,50°	9	0 – 4,8	1,01°	18
12	300	323,9	0 – 2,4	0,42°	7,5	0 – 4,8	0,85°	15

*Note! Bearing in mind the design goals, the safety factor was taken into account in the values given in the table above

Absorbing vibrations and noise

When the pump is in the frequent on and off mode, the piping system is exposed to noise and vibrations. The entire system can be significantly swayed which is referred to as resonant vibrations and occurs as a result of frequently repeated cycles. KAN-therm Groove flexible couplings help to reduce this type of vibrations and the related noise. The system should always be properly secured with steel angle stabilizers which protects it against significant swinging.

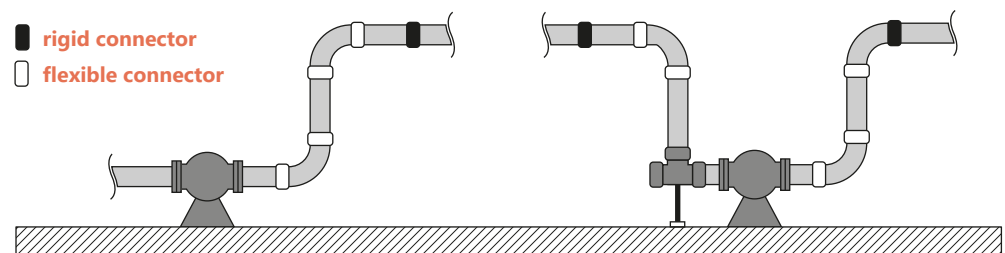

Correction of misalignment

If a simple course requires a slight adjustment of the setting, as shown in the diagram, two flexible couplings can be used. The deflection value (δ) for elastic couplings KAN-therm Groove 7705 is given in the table below.

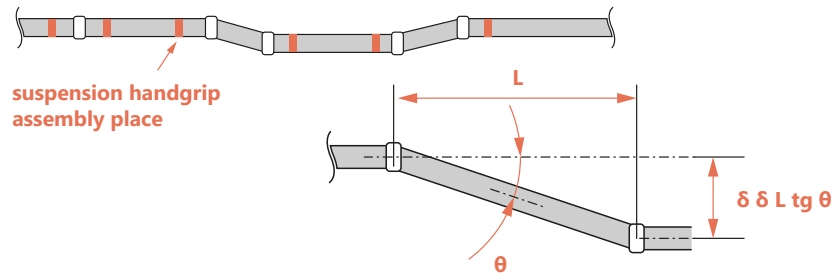

Deflection dimension (δ)						
Nominal dimension	Deflection angle (θ)	Distance between the couplings (L) mm				
		600	1200	1500	2000	3000
2"/50	3° 02'	32	64	79	106	159
2½"/65	2° 30'	26	52	65	87	131
3"/80	2° 04'	22	43	54	72	108
4"/100	3° 12'	34	67	84	112	168
5"/125	2° 36'	27	54	68	91	136
6"/150	1° 10'	12	24	31	41	61
8"/200	1° 40'	17	35	44	58	87
10"/250	1° 20'	14	28	35	47	70
12"/300	1° 08'	12	24	30	40	59

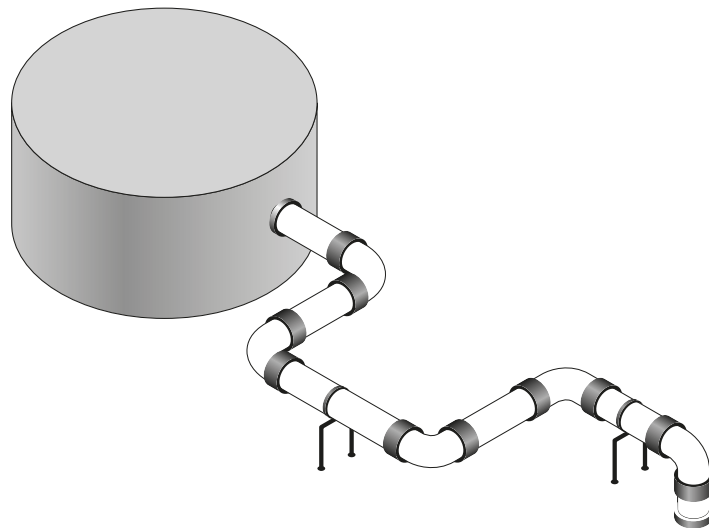

Compensation of inter-ceiling deflection

When an earthquake strikes, vertical strings of high building structures are subjected to lateral swaying (inter-ceiling deflection). If it is assumed that the inter-ceiling deflection is 1/150 and the ceiling height (H) is 4 meters, the estimated inter-ceiling deflection (A) will be:

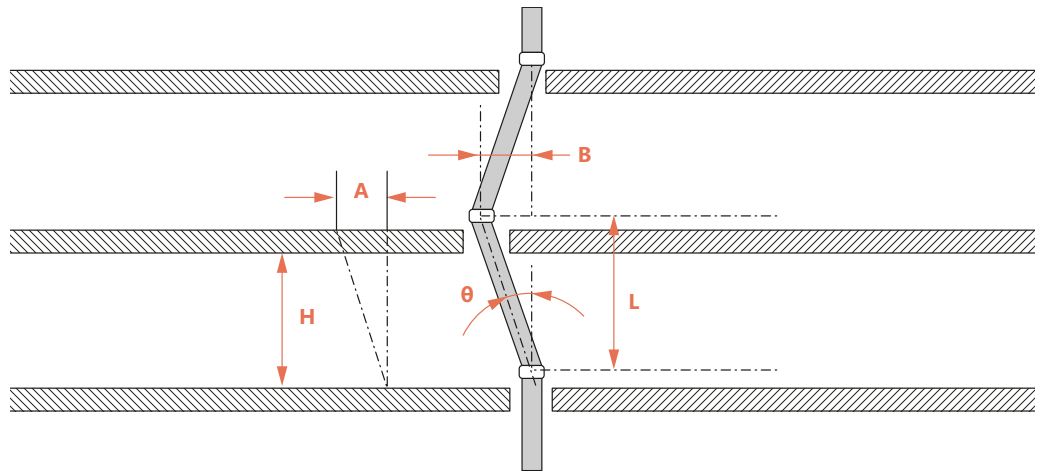

$$A = H \times 1/150 = 4000 \times 1/150 = 27 \text{ mm}$$

If a 200 mm (8") 7707 coupling is used for each floor, the maximum deflection (B) compensated by each coupling will be:

$$B = L \times \tan \theta = 4000 \times 0,02915 = 4,56'' = 116 \text{ mm } (\theta = 1,67^\circ)$$

The example shows that the flexible coupling will be able to compensate for the seismic shock at a certain scale.

Misalignment compensation

As shown in the diagram, each branch from free vertical thrust is subjected to high lateral forces, due to increasing pressure and increased thermal movement. The use of two flexible couplings can solve this problem.

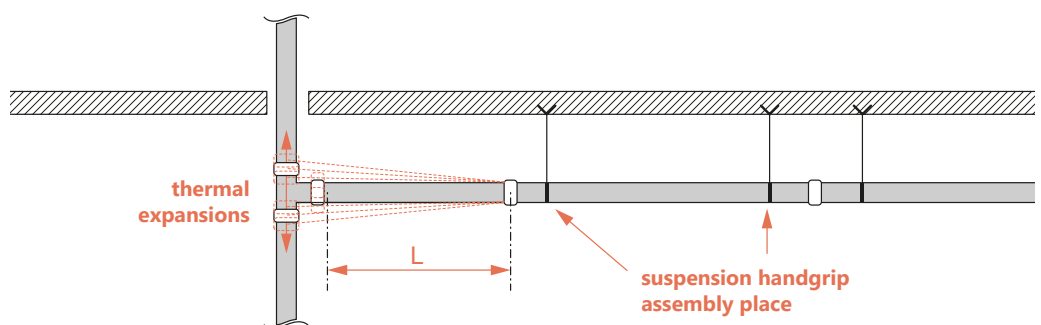

Curved pipeline

Thanks to the KAN-therm Groove flexible couplings, a curved pipeline running along a curved tunnel, a winding road or a curved building can be designed.

$$R = \frac{L}{2 \times \sin(\theta/2)}$$

Where: R is the radius of curvature, L is the length of the pipe and θ is the maximum permissible deflection of the coupling.

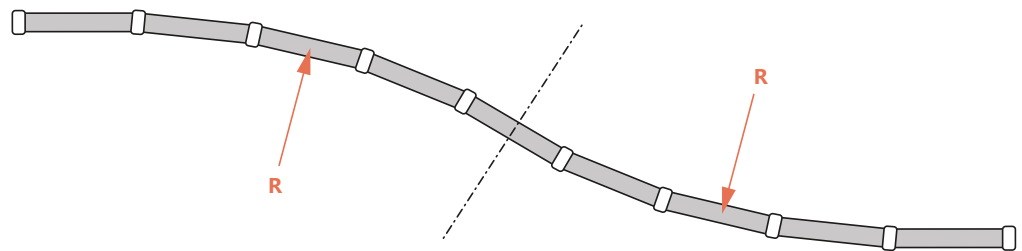

For example, using a 100 mm (4") 7705 coupling in the pipeline shown in the diagram, the maximum permissible deflection (θ) of the coupling will be 3,4°, the pipe length (L) will be 5,5 meters, and the radius of curvature (R) reaches 92,7 meters.

Absorption of thermal stresses

Thermal stresses result from temperature changes that cause the material to expand or shrink. With the KAN-therm Groove flexible couplings, the system can be designed to compensate for this type of movement without the need for costly compensating couplings. The expansion or heat shrinkage (μ) depends on the length of the pipe (L) and the temperature difference (ΔT).

$$\mu = \alpha \times L \times \Delta T$$

Thermal expansion (metric system) sion (mm)						
Temperature difference ΔT (°C)	Pipe length L (in metres)					
	1	5,5	10	20	30	40
Thermal expansion (in millimetres)						
1	0,012	0,07	0,12	0,24	0,36	0,48
5	0,06	0,33	0,6	1,2	1,8	2,4
10	0,12	0,66	1,2	2,4	3,6	4,8
20	0,24	1,3	2,4	4,8	7,2	9,6
30	0,36	2	3,6	7,2	11	15
40	0,48	2,6	4,8	9,6	14	20
50	0,6	3,3	6	12	18	24
60	0,72	4	7,2	14	22	29
70	0,84	4,6	8,4	17	25	34
80	0,96	5,3	9,6	19	29	39

As the coefficient of linear expansion for steel (α) is $1,2 \times 10^{-5}$, the above table can be used to determine the value of thermal expansion. Example:

- Pipe dimension: 100 mm (4")
- Max. separation of pipe ends (E): 3,2 mm
- Pipe length (L): 5500 mm
- Temperature difference (ΔT): 40 °C (from +5 °C to +45 °C)
- $\alpha = 1,2 \times 10^{-5} / ^\circ\text{C}$

$$\mu = \alpha \times L \times \Delta T = 1,2 \times 10^{-5} / ^\circ\text{C} \times 5500 \text{ mm} \times 40 \text{ } ^\circ\text{C} = 2,64 \text{ mm}$$

Thermal expansion of a standard length pipe of 5.5 meters (μ) is within the limits (= max. pipe end separation) permissible for the flexible coupling. In other words, if a flexible coupling for each 5.5-meter pipe is used, this coupling will compensate for expansion or thermal shrinkage under temperature changes of 40 °C. After calculating the necessary number of flexible couplings (N) for the anchoring system, leave clearance, calculated according to the formula $N \times E \times 1/2$, acting as a safety factor.

Regardless of whether there is a phenomenon of expansion or heat shrinkage or their alternating occurrence, the system requires the use of applicable anchoring systems with guides that align space and elements supporting the weight. Where greater thermal movement is anticipated, additional expansion couplings should be used.

2.9 Anchoring, hanging and brackets

KAN-therm Groove grooved couplings are designed to withstand axial loads of 4–5 times greater than their nominal operating pressure, even though their bending strength is lower than for steel pipes. The coupling can be damaged by the occurrence of a bending motion exceeding the maximum value of the permissible deflection. System designers should provide anchors (main and intermediate) and pipe guides that provide adequate spacing to protect the system from unexpected large bending movements.

The pictures presented are of illustration nature only and should not be used as examples because the conditions and requirements vary depending on the situation. Relying on general data and information provided in this document is the sole risk of the user and KAN Sp. z o.o. does not bear any responsibility for this.

Suspension holders should be designed to be able to support five times the weight of a pipe filled with water plus an additional 250 pounds (115 kg) at each point of the tube support (NFPA 13 9.1.1.1). Illustrations below present examples of permissible types and dimensions of holders according to NFPA 13.

Dimensions of U-type hook handles

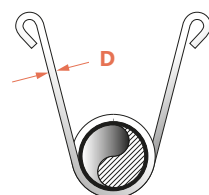

roll-up hook handle

Pipe dimension	Dimension D	
	inches	mm
≤ 2	5/16	7,9
2 1/2 – 6	3/8	(9,5
8	1/2	12,7

Dimensions of fixing rods



adjusted bar with rotation
pipe-adherent ring

Pipe dimension	Dimension D	
	inches	mm
≤ 4	3/8	9,5
5 – 8	1/2	12,7
10 – 12	5/8	15,9

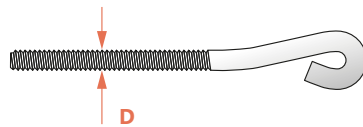

Pipe dimension	Dimension D	
	inches	mm
≤ 4	3/8	9,5
5 – 6	1/2	12,7
10 – 12	3/4	15,1

Handles for straight sections

In the case of straight sections, both rigid and flexible couplings can be used. If rigid couplings are used, the same grip spacing can be used as for other pipe design methods. We encourage you to familiarize with the grip spacing standards according to ANSI B31.1 Power Piping Code, B31.9 Building Services Piping Code, NFPA 13 Sprinkler Systems or Mechanical Equipment Construction Guide (Japan). See table below.

Suggested max. spacing between the bearers (steel pipe)

Nominal pipe dimension inches/mm	Water system (feet/metres)				Gas or air system (feet/metres)		
	1)	2)	3)	4)	1)	2)	3)
1 / 25	7 / 2,1	9 / 2,7	12 / 3,7	6,6 / 2,0	9 / 2,7	10 / 3,0	12 / 3,7
1 1/4 / 32	7 / 2,1	11 / 3,4	12 / 3,7	6,6 / 2,0	9 / 2,7	12 / 3,7	12 / 3,7
1 1/2 / 40	7 / 2,1	12 / 3,7	15 / 4,6	6,6 / 2,0	9 / 2,7	13 / 4,0	15 / 4,6
2 / 50	10 / 3,0	13 / 4,0	15 / 4,6	6,6 / 2,0	13 / 4,0	15 / 4,6	15 / 4,6
2 1/2 / 65	11 / 3,4	15 / 4,6	15 / 4,6	6,6 / 2,0	14 / 4,3	17 / 5,2	15 / 4,6
3 / 80	12 / 3,7	16 / 4,9	15 / 4,6	6,6 / 2,0	15 / 4,6	19 / 5,8	15 / 4,6
4 / 100	14 / 4,3	18 / 5,5	15 / 4,6	6,6 / 2,0	17 / 5,2	21 / 6,4	15 / 4,6
5 / 125	16 / 4,9	20 / 6,1	15 / 4,6	6,6 / 2,0	20 / 6,1	24 / 7,3	15 / 4,6
6 / 150	17 / 5,2	21 / 6,4	15 / 4,6	10 / 3,0	21 / 6,4	26 / 7,9	15 / 4,6
8 / 200	19 / 5,8	23 / 7,0	15 / 4,6	10 / 3,0	24 / 7,3	29 / 8,8	15 / 4,6
10 / 250	19 / 5,8	25 / 7,6	15 / 4,6	10 / 3,0	24 / 7,3	33 / 10,1	15 / 4,6
12 / 300	23 / 7,0	26 / 7,9	15 / 4,6	10 / 3,0	30 / 9,1	36 / 11,0	15 / 4,6

1) ANSI B31.1 Power Piping Code

2) ANSI B31.9 Building Services Piping Code

3) NFPA 13 Sprinkler Systems

4) Japanese Ministry of Infrastructure and Transport: Mechanical Equipment Construction Guide

Assembly points for handles on straight sections using flexible couplings

If that flexible couplings are used on a simple pipeline run, the retaining handles should be mounted as close as possible to each coupling or within a distance not exceeding $1/6$ of the spacing.

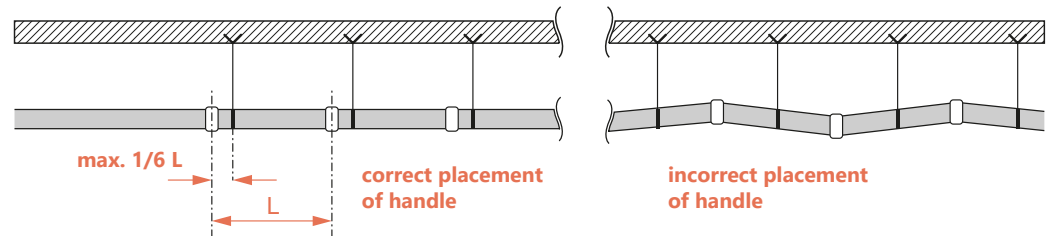

Assembly points for handles on curved and branching patterns

In the case of curved runs connected to the branch, short vertical string or bleed, additional brackets or brackets should be used.

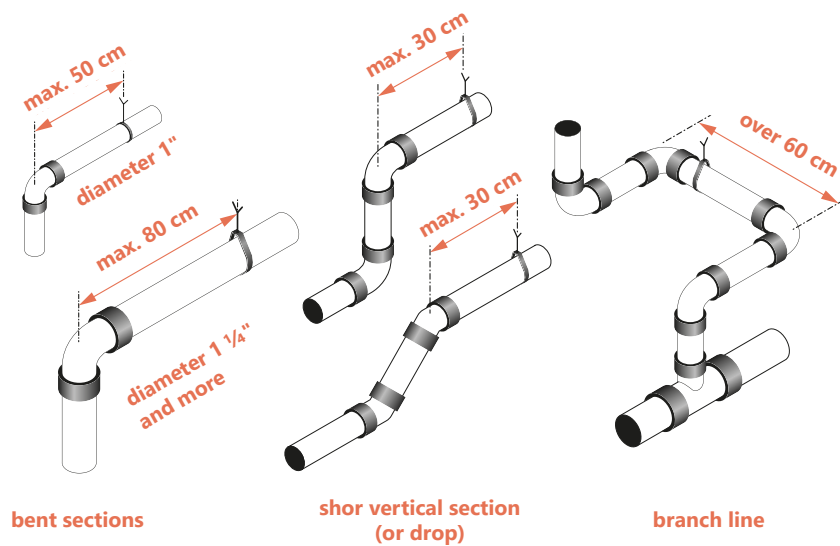

Typical designs of suspensions and clamps

Pipelines should be suitably anchored by means of bars or steel angle sections which are directly attached to the building structure in order to limit movement of the pipelines. Hangers and their components should be made of steel. The maximum distance between hangers is given in the table on the previous pages.

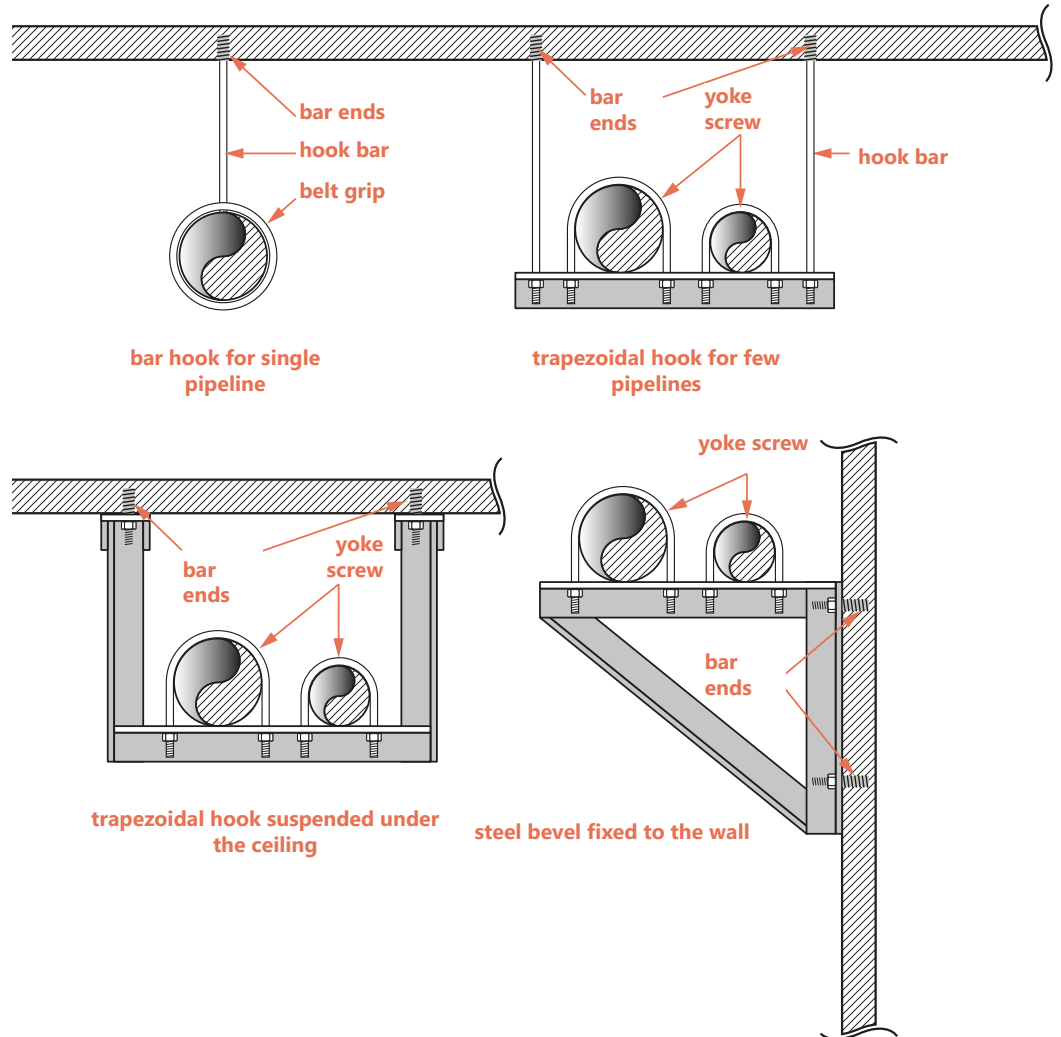

Brackets for vertical ducts

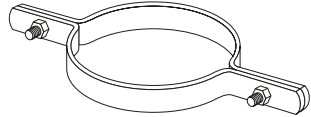

In multi-storey buildings, vertical ducts should be fixed (or anchored) at the lowest level and at the top of the stack and should be supported by clamps or shackle bolts at the level of each ceiling to prevent the ducts from swaying. If the vertical ducts have been stiffened by punctures in the ceilings, the number of clamps or shackle bolts can be reduced to one piece for every three floors. In the case of vertical ducts, both rigid and flexible couplings can be used, provided that adequate anchoring and fixing are provided.

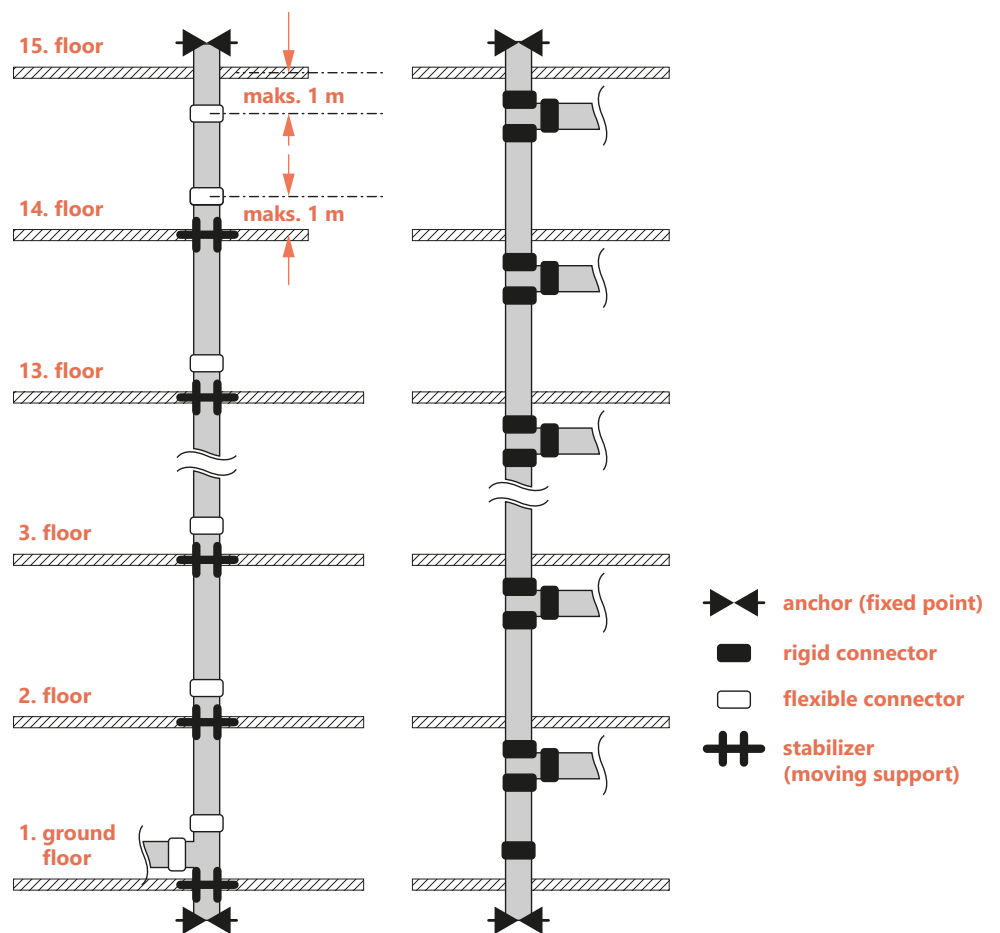

- Anchors should support the weight of the pipe filled with water and withstand pressure forces.
- Pipe guides (stabilizers/sliding supports) should stabilize the lateral movement of the system.

vertical line anchors

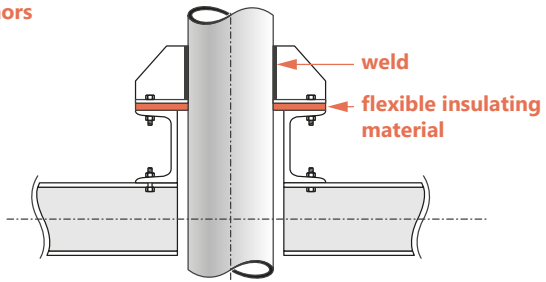

vertical line stabilizers

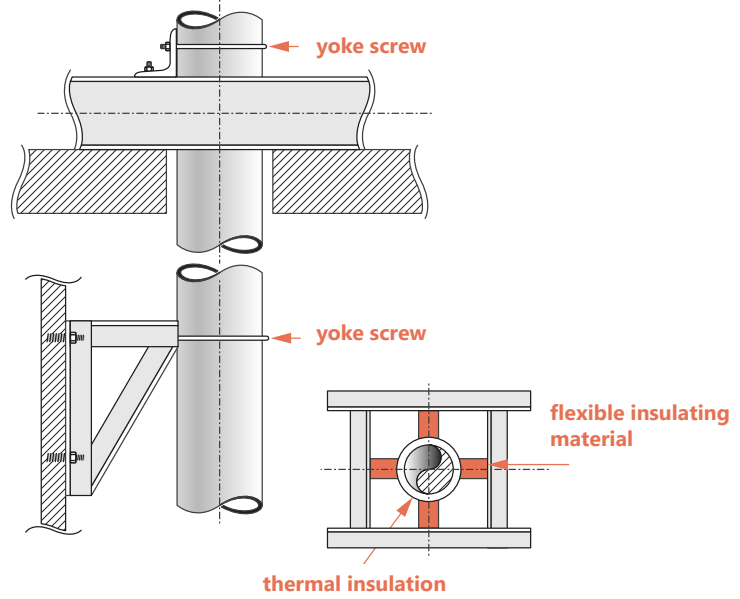



SYSTEM KAN-therm Groove

Fittings

Orange rigid coupling 
(connection to oblique bolt clamp with class E gasket)

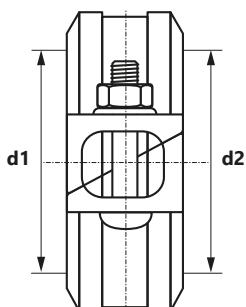
Z05
GROUP: S





Size (d1=d2)	Code	*			UM
42,4 (DN 32)	2457301000		1	26	pc.
48,3 (DN 40)	2457301001		1	24	pc.
60,3 (DN 50)	2457301002		1	16	pc.
76,1 (DN 65)	2457301003		1	12	pc.
88,9 (DN 80)	2457301004		1	10	pc.
114,3 (DN 100)	2457301005		1	12	pc.
139,7 (DN 125)	2457301006		1	8	pc.
168,3 (DN 150)	2457301007		1	3	pc.
219,1 (DN 200)	2457301008		1	3	pc.

Galvanized rigid coupling 
(connection to oblique bolt clamp with class E gasket)

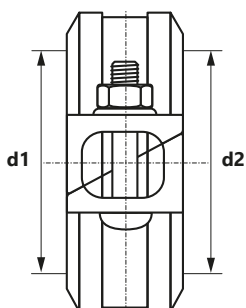
Z05
GROUP: S



Size (d1=d2)	Code	*			UM
42,4 (DN 32)	2455301004		1	26	pc.
48,3 (DN 40)	2455301005		1	24	pc.
60,3 (DN 50)	2455301006		1	16	pc.
76,1 (DN 65)	2455301000		1	12	pc.
88,9 (DN 80)	2455301001		1	10	pc.
114,3 (DN 100)	2455301002		1	12	pc.
139,7 (DN 125)	2455301007		1	8	pc.
168,3 (DN 150)	2455301003		1	6	pc.
219,1 (DN 200)	2455301008		1	3	pc.



 coil  bar  pipes in tube  bag  carton box  pallet  new  available soon

* on request (delivery time up to 4 weeks) | ** availability by individual arrangements | *** till stock ends

Red rigid coupling 
(with class E gasket)

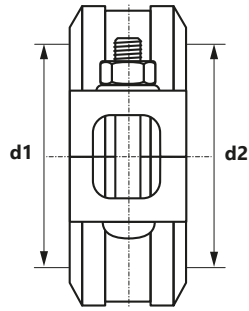
K9
GROUP: S





Size (d1=d2)	Code	*			UM
42,4 (DN 32)	2458301000		1	26	pc.
48,3 (DN 40)	2458301001		1	22	pc.
60,3 (DN 50)	2458301002		1	18	pc.
76,1 (DN 65)	2458301003		1	25	pc.
88,9 (DN 80)	2458301004		1	20	pc.
114,3 (DN 100)	2458301005		1	12	pc.
139,7 (DN 125)	2458301006		1	9	pc.
168,3 (DN 150)	2458301007		1	7	pc.
219,1 (DN 200)	2458301008		1	3	pc.

Galvanized rigid coupling 
(with class E gasket)

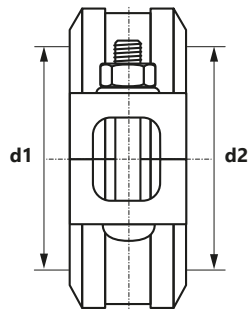
K9
GROUP: S



Size (d1=d2)	Code	*			UM
42,4 (DN 32)	2456301000		1	26	pc.
48,3 (DN 40)	2456301001		1	22	pc.
60,3 (DN 50)	2456301002		1	18	pc.
76,1 (DN 65)	2456301003		1	25	pc.
88,9 (DN 80)	2456301004		1	20	pc.
114,3 (DN 100)	2456301005		1	12	pc.
139,7 (DN 125)	2456301006		1	9	pc.
168,3 (DN 150)	2456301007		1	7	pc.
219,1 (DN 200)	2456301008		1	3	pc.



 coil  bar  pipes in tube  bag  carton box  pallet  new  available soon

* on request (delivery time up to 4 weeks) | ** availability by individual arrangements | *** till stock ends

Orange rigid HD coupling 
(connection to oblique bolt clamp with class E gasket)

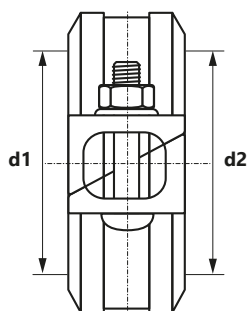
Z07
GROUP: S





Size (d1=d2)	Code	*			UM
42,4 (DN 32)	2457314000		1	24	pc.
48,3 (DN 40)	2457314001		1	20	pc.
60,3 (DN 50)	2457314002		1	16	pc.
76,1 (DN 65)	2457314003		1	12	pc.
88,9 (DN 80)	2457314004		1	9	pc.
114,3 (DN 100)	2457314005		1	5	pc.
139,7 (DN 125)	2457314006		1	7	pc.
168,3 (DN 150)	2457314007		1	6	pc.
219,1 (DN 200)	2457314008		1	3	pc.
273,0 (DN 250)	2457314009		-	1	pc.
323,9 (DN 300)	2457314010		-	1	pc.

Galvanized rigid HD coupling 
(connection to oblique bolt clamp with class E gasket)

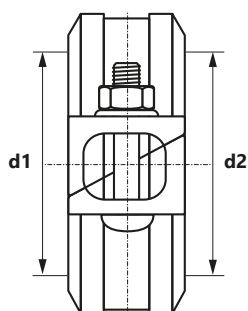
Z07
GROUP: S



Size (d1=d2)	Code	*			UM
42,4 (DN 32)	2455314000		1	24	pc.
48,3 (DN 40)	2455314001		1	20	pc.
60,3 (DN 50)	2455314002		1	16	pc.
76,1 (DN 65)	2455314003		1	12	pc.
88,9 (DN 80)	2455314004		1	9	pc.
114,3 (DN 100)	2455314005		1	5	pc.
139,7 (DN 125)	2455314006		1	7	pc.
168,3 (DN 150)	2455314007		1	6	pc.
219,1 (DN 200)	2455314008		1	3	pc.
273,0 (DN 250)	2455314009		-	1	pc.
323,9 (DN 300)	2455314010		-	1	pc.



 coil  bar  pipes in tube  bag  carton box  pallet  new  available soon

* on request (delivery time up to 4 weeks) | ** availability by individual arrangements | *** till stock ends

Orange flexible HD coupling 
(with class E gasket)

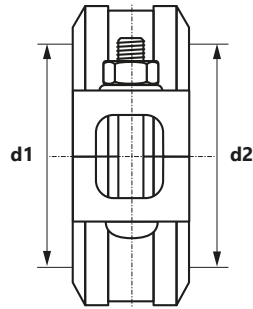
7707
GROUP: S





Size (d1=d2)	Code	*			UM
33,7 (DN 25)	2457313000		1	26	pc.
42,4 (DN 32)	2457313001		1	18	pc.
48,3 (DN 40)	2457313002		1	18	pc.
60,3 (DN 50)	2457313003		1	14	pc.
76,1 (DN 65)	2457313004		1	10	pc.
88,9 (DN 80)	2457313005		1	9	pc.
114,3 (DN 100)	2457313006		1	5	pc.
139,7 (DN 125)	2457313007		1	7	pc.
168,3 (DN 150)	2457313008		1	3	pc.
219,1 (DN 200)	2457313009		1	3	pc.
273,0 (DN 250)	2457313010		-	1	pc.
323,9 (DN 300)	2457313011		-	1	pc.

Galvanized flexible HD coupling 
(with class E gasket)

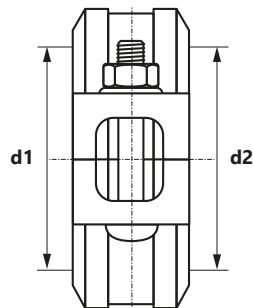
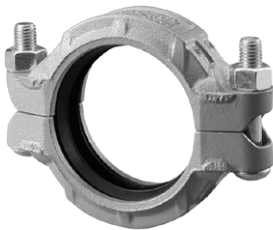
7707
GROUP: S



Size (d1=d2)	Code	*			UM
42,4 (DN 32)	2455313000		1	18	pc.
48,3 (DN 40)	2455313001		1	18	pc.
60,3 (DN 50)	2455313002		1	14	pc.
76,1 (DN 65)	2455313003		1	10	pc.
88,9 (DN 80)	2455313004		1	9	pc.
114,3 (DN 100)	2455313005		1	5	pc.
139,7 (DN 125)	2455313006		1	7	pc.
168,3 (DN 150)	2455313007		1	3	pc.
219,1 (DN 200)	2455313008		1	3	pc.
273,0 (DN 250)	2455313009		-	1	pc.
323,9 (DN 300)	2455313010		-	1	pc.



 coil  bar  pipes in tube  bag  carton box  pallet  new  available soon

* on request (delivery time up to 4 weeks) | ** availability by individual arrangements | *** till stock ends

Orange flexible coupling 
(with class E gasket)

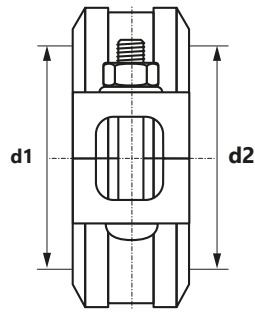
**7705
GROUP: S**





Size (d1=d2)	Code	*			UM
33,7 (DN 25)	2457312000		1	30	pc.
42,4 (DN 32)	2457312001		1	26	pc.
48,3 (DN 40)	2457312002		1	22	pc.
60,3 (DN 50)	2457312003		1	16	pc.
76,1 (DN 65)	2457312004		1	12	pc.
88,9 (DN 80)	2457312005		1	9	pc.
114,3 (DN 100)	2457312006		1	4	pc.
139,7 (DN 125)	2457312007		1	8	pc.
168,3 (DN 150)	2457312008		1	6	pc.
219,1 (DN 200)	2457312009		1	3	pc.

Galvanized flexible coupling 
(with class E gasket)

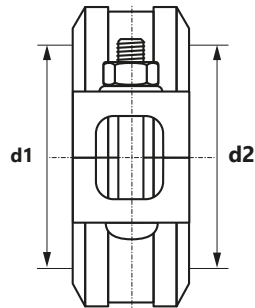
**7705
GROUP: S**



Size (d1=d2)	Code	*			UM
33,7 (DN 25)	2455312000		1	30	pc.
42,4 (DN 32)	2455312001		1	26	pc.
48,3 (DN 40)	2455312002		1	22	pc.
60,3 (DN 50)	2455312003		1	16	pc.
76,1 (DN 65)	2455312004		1	12	pc.
88,9 (DN 80)	2455312005		1	9	pc.
114,3 (DN 100)	2455312006		1	4	pc.
139,7 (DN 125)	2455312007		1	8	pc.
168,3 (DN 150)	2455312008		1	6	pc.
219,1 (DN 200)	2455312009		1	3	pc.



 coil  bar  pipes in tube  bag  carton box  pallet  new  available soon

* on request (delivery time up to 4 weeks) | ** availability by individual arrangements | *** till stock ends

Red reducing coupling 
(with class E gasket)

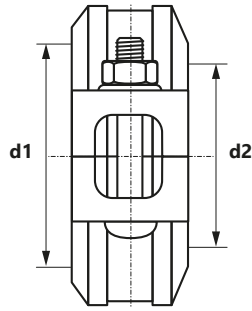
7706
GROUP: S





Size (d1 × d2)	Code	*			UM
60,3 (DN 50) × 48,3 (DN 40)	2457046000		1	16	pc.
76,1 (DN 65) × 60,3 (DN 50)	2457046001		1	12	pc.
88,9 (DN 80) × 60,3 (DN 50)	2457046002		1	9	pc.
88,9 (DN 80) × 76,1 (DN 65)	2457046003		1	9	pc.
114,3 (DN 100) × 60,3 (DN 50)	2457046004		1	5	pc.
114,3 (DN 100) × 76,1 (DN 65)	2457046005		1	5	pc.
114,3 (DN 100) × 88,9 (DN 80)	2457046006		1	10	pc.
139,7 (DN 125) × 114,3 (DN 100)	2457046007		1	4	pc.
168,3 (DN 150) × 114,3 (DN 100)	2457046008		1	3	pc.
219,1 (DN 200) × 168,3 (DN 150)	2457046009		1	3	pc.

Galvanized reducing coupling 
(with class E gasket)

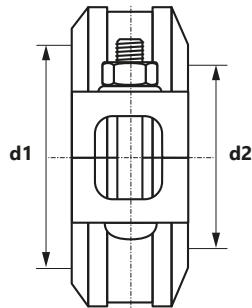
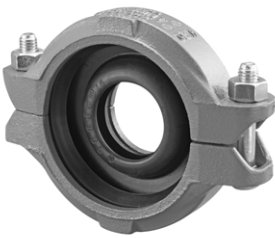
7706
GROUP: S



Size (d1 × d2)	Code	*			UM
60,3 (DN 50) × 48,3 (DN 40)	2455046000		1	16	pc.
76,1 (DN 65) × 60,3 (DN 50)	2455046001		1	12	pc.
88,9 (DN 80) × 60,3 (DN 50)	2455046002		1	9	pc.
88,9 (DN 80) × 76,1 (DN 65)	2455046003		1	9	pc.
114,3 (DN 100) × 60,3 (DN 50)	2455046004		1	5	pc.
114,3 (DN 100) × 76,1 (DN 65)	2455046005		1	5	pc.
114,3 (DN 100) × 88,9 (DN 80)	2455046006		1	10	pc.
139,7 (DN 125) × 114,3 (DN 100)	2455046007		1	4	pc.
168,3 (DN 150) × 114,3 (DN 100)	2455046008		1	3	pc.
219,1 (DN 200) × 168,3 (DN 150)	2455046009		1	3	pc.



 coil  bar  pipes in tube  bag  carton box  pallet  new  available soon

* on request (delivery time up to 4 weeks) | ** availability by individual arrangements | *** till stock ends

Orange wildcat type coupling 
(2x smooth ends, with class E gasket)

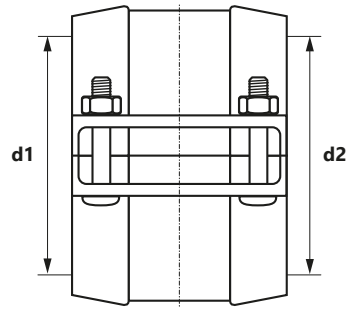
79
GROUP: S





Size (d1×d2)	Code	*			UM
60,3 (DN 50)	2457323000		1	6	pc.
88,9 (DN 80)	2457323001		1	4	pc.
114,3 (DN 100)	2457323002		1	3	pc.
168,3 (DN 150)	2457323003		1	2	pc.
219,1 (DN 200)	2457323004		-	1	pc.

HDPE/Groove coupling

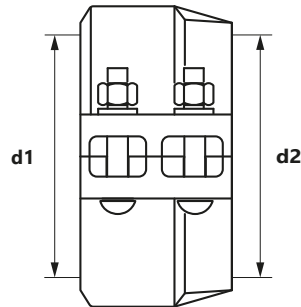
H307
GROUP: S



Size (d1/d2)	Code	*			UM
63/60,3 (DN 50)	2457042031		-	14	pc.
90/88,9 (DN 80)	2457042033		-	10	pc.
110/114,3 (DN 100)	2457042034		-	6	pc.
160/165,1 (DN 150)	2457042035		-	1	pc.
160/168,3 (DN 150)	2457042036		-	3	pc.
200/219,1 (DN 200)	2457042037		-	1	pc.
250/273 (DN 250)	2457042038		-	1	pc.
315/323,9 (DN 300)	2457042039		-	1	pc.

 coil  bar  pipes in tube  bag  carton box  pallet **N** new **!** available soon

* on request (delivery time up to 4 weeks) | ** availability by individual arrangements | *** till stock ends

Painted HDPE coupling

H305
GROUP: S

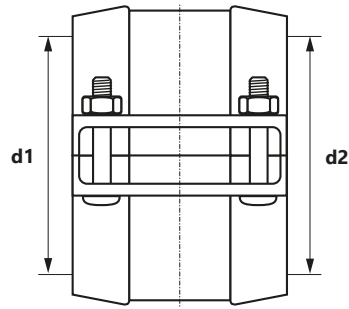

Size (d1=d2)	Code	*			UM
50	2457042030	-	-	1	pc.
63	2457042014	-	-	1	pc.
75	2457042015	-	-	1	pc.
90	2457042016	-	-	1	pc.
110	2457042017	-	-	1	pc.
140	2457042019	-	-	1	pc.
160	2457042020	-	-	1	pc.
180	2457042021	-	-	1	pc.
200	2457042022	-	-	1	pc.
225	2457042023	-	-	1	pc.
250	2457042024	-	-	1	pc.
280	2457042025	-	-	1	pc.
315	2457042026	-	-	1	pc.
355	2457042027	-	-	1	pc.
400	2457042028	-	-	1	pc.
450	2457042029	-	-	1	pc.

Painted flange adapter

PN10/PN16 (DN50-300 hinge, DN350-600 two-part, with class E gasket)

7041
GROUP: S

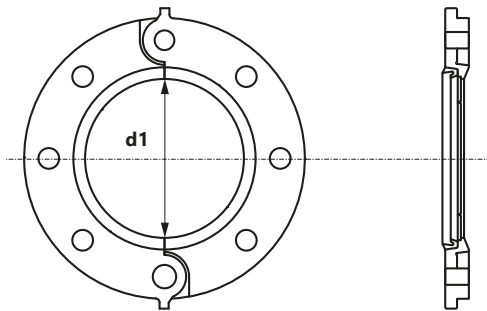

Size (d1)	Code	*			UM
60,3 (DN 50)	2457091000	-	-	1	pc.
76,1 (DN 65)	2457091001	-	-	1	pc.
88,9 (DN 80)	2457091002	-	-	1	pc.
114,3 (DN 100)	2457091003	-	-	1	pc.
139,7 (DN 125)	2457091004	-	-	1	pc.
168,3 (DN 150)	2457091005	-	-	1	pc.
219,1 (DN 200)	2457091006	-	-	1	pc.
323,9 (DN 300)	2457091007	-	-	1	pc.

coil bar pipes in tube bag carton box pallet new available soon



* on request (delivery time up to 4 weeks) | ** availability by individual arrangements | *** till stock ends

Galvanized flange adapter

PN10/PN16 (DN50-300 hinge, DN350-600 two-part, with class E gasket)

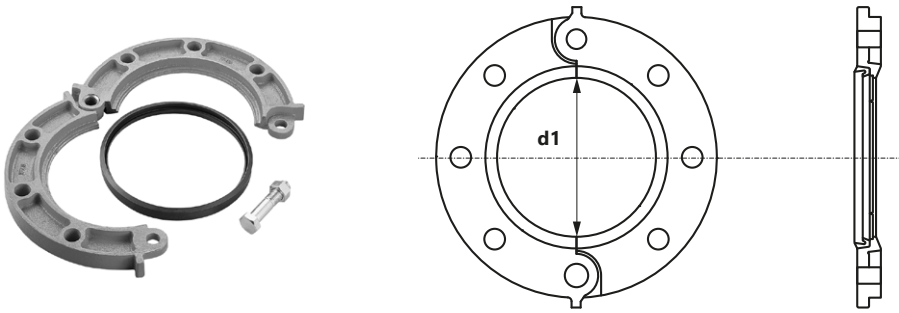
7041
GROUP: S





Size (d1)	Code	*			UM
60,3 (DN 50)	2455091000		-	1	pc.
76,1 (DN 65)	2455091001		-	1	pc.
88,9 (DN 80)	2455091002		-	1	pc.
114,3 (DN 100)	2455091003		-	1	pc.
139,7 (DN 125)	2455091004		-	1	pc.
168,3 (DN 150)	2455091005		-	1	pc.
219,1 (DN 200)	2455091006		-	1	pc.
323,9 (DN 300)	2455091007		-	1	pc.

Flat gasket

(sandwich plates - contain fibre and galvanized steel)

49
GROUP: S



Size	Code	*			UM
DN50	2409237000		1	140	pc.
DN65	2409237001		1	110	pc.
DN80	2409237002		1	80	pc.
DN100	2409237003		1	70	pc.
DN125	2409237004		1	60	pc.
DN150	2409237005		1	40	pc.
DN200	2409237006		1	35	pc.
DN250	2409237007		1	10	pc.
DN300	2409237008		-	1	pc.

 coil  bar  pipes in tube  bag  carton box  pallet  new  available soon

* on request (delivery time up to 4 weeks) | ** availability by individual arrangements | *** till stock ends

Orange elbow 90°
(2x groove)

7110
GROUP: S

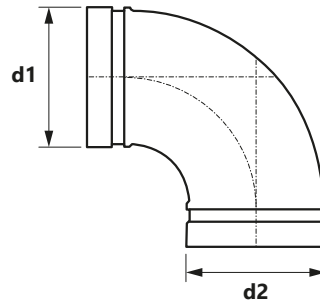

Size (d1 × d2)	Code	*				UM
33,7 (DN 25)	2457302000		1	60	pc.	
42,4 (DN 32)	2457302001		1	28	pc.	
48,3 (DN 40)	2457302002		1	24	pc.	
60,3 (DN 50)	2457302003		1	12	pc.	
76,1 (DN 65)	2457302004		1	12	pc.	
88,9 (DN 80)	2457302005		1	9	pc.	
114,3 (DN 100)	2457302006		1	5	pc.	
139,7 (DN 125)	2457302007		1	3	pc.	
168,3 (DN 150)	2457302008		-	1	pc.	
219,1 (DN 200)	2457302009		-	1	pc.	
273,0 (DN 250)	2457302010		-	1	pc.	
323,9 (DN 300)	2457302011		-	1	pc.	

Galvanized elbow 90°
(2x groove)

7110
GROUP: S

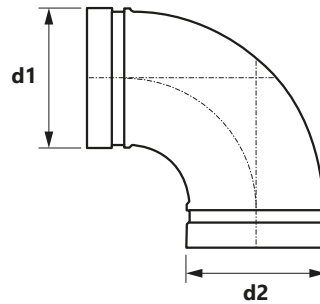

Size (d1 × d2)	Code	*				UM
33,7 (DN 25)	2455302004		1	60	pc.	
42,4 (DN 32)	2455302005		1	28	pc.	
48,3 (DN 40)	2455302006		1	24	pc.	
60,3 (DN 50)	2455302007		1	12	pc.	
76,1 (DN 65)	2455302000		1	12	pc.	
88,9 (DN 80)	2455302001		1	9	pc.	
114,3 (DN 100)	2455302002		1	5	pc.	
139,7 (DN 125)	2455302008		1	3	pc.	
168,3 (DN 150)	2455302003		-	1	pc.	
219,1 (DN 200)	2455302009		-	1	pc.	
273,0 (DN 250)	2455302010		-	1	pc.	
323,9 (DN 300)	2455302011		-	1	pc.	

coil bar pipes in tube bag carton box pallet new available soon

* on request (delivery time up to 4 weeks) | ** availability by individual arrangements | *** till stock ends

Red short elbow 90°
(small bending radius)

901
GROUP: S

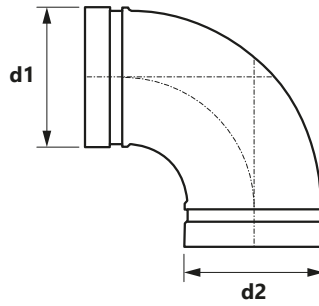

Size (d1 × d2)	Code	*							UM
60,3 (DN 50)	2458321000						1	30	pc.
76,1 (DN 65)	2458321001						1	16	pc.
88,9 (DN 80)	2458321002						1	12	pc.
114,3 (DN 100)	2458321003						1	6	pc.
139,7 (DN 125)	2458321004						1	4	pc.
168,3 (DN 150)	2458321005						1	2	pc.
219,1 (DN 200)	2458321006						-	1	pc.

Galvanized short elbow 90°
(small bending radius)

901
GROUP: S

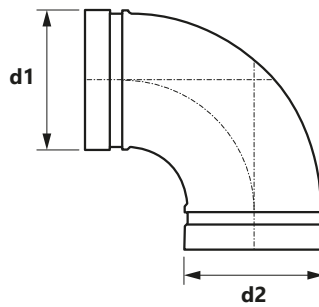

Size (d1 × d2)	Code	*							UM
60,3 (DN 50)	2456321000						1	30	pc.
76,1 (DN 65)	2456321001						1	16	pc.
88,9 (DN 80)	2456321002						1	12	pc.
114,3 (DN 100)	2456321003						1	6	pc.
139,7 (DN 125)	2456321004						1	4	pc.
168,3 (DN 150)	2456321005						1	2	pc.
219,1 (DN 200)	2456321006						-	1	pc.

coil bar pipes in tube bag carton box pallet new available soon

* on request (delivery time up to 4 weeks) | ** availability by individual arrangements | *** till stock ends

Orange elbow 45°

7111
GROUP: S

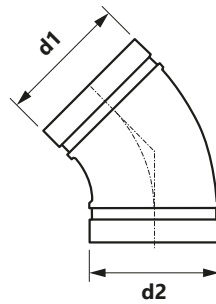

Size (d1 × d2)	Code	*				UM
33,7 (DN 25)	2457303000			1	72	pc.
42,4 (DN 32)	2457303001			1	40	pc.
48,3 (DN 40)	2457303002			1	36	pc.
60,3 (DN 50)	2457303003			1	36	pc.
76,1 (DN 65)	2457303004			1	18	pc.
88,9 (DN 80)	2457303005			1	15	pc.
114,3 (DN 100)	2457303006			1	6	pc.
139,7 (DN 125)	2457303007			1	4	pc.
168,3 (DN 150)	2457303008			1	2	pc.
219,1 (DN 200)	2457303009			-	1	pc.
273,0 (DN 250)	2457303010			-	1	pc.
323,9 (DN 300)	2457303011			-	1	pc.

Galvanized elbow 45°

7111
GROUP: S

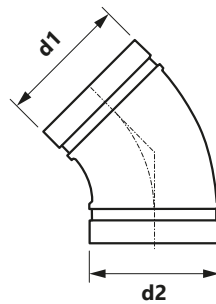

Size (d1 × d2)	Code	*				UM
33,7 (DN 25)	2455303004			1	72	pc.
42,4 (DN 32)	2455303005			1	40	pc.
48,3 (DN 40)	2455303006			1	36	pc.
60,3 (DN 50)	2455303007			1	36	pc.
76,1 (DN 65)	2455303000			1	18	pc.
88,9 (DN 80)	2455303001			1	15	pc.
114,3 (DN 100)	2455303002			1	6	pc.
139,7 (DN 125)	2455303008			1	4	pc.
168,3 (DN 150)	2455303003			1	2	pc.
219,1 (DN 200)	2455303009			-	1	pc.
273,0 (DN 250)	2455303010			-	1	pc.
323,9 (DN 300)	2455303011			-	1	pc.

coil bar pipes in tube bag carton box pallet new available soon

* on request (delivery time up to 4 weeks) | ** availability by individual arrangements | *** till stock ends

Red elbow 45°

7111
GROUP: S

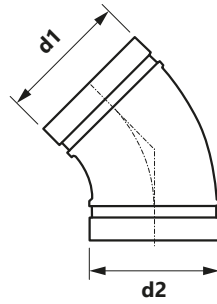

Size (d1 × d2)	Code	*			UM
60,3 (DN 50)	2458303000		1	36	pc.
76,1 (DN 65)	2458303001		1	18	pc.
88,9 (DN 80)	2458303002		1	15	pc.
114,3 (DN 100)	2458303003		1	6	pc.
139,7 (DN 125)	2458303004		1	4	pc.
168,3 (DN 150)	2458303005		1	2	pc.
219,1 (DN 200)	2458303006		-	1	pc.

Orange elbow 22.5° (2x groove)

7112
GROUP: S

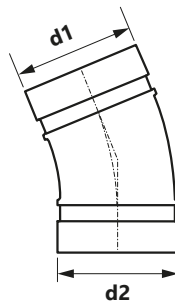

Size (d1 × d2)	Code	*			UM
42,4 (DN 32)	2457304000		1	48	pc.
48,3 (DN 40)	2457304001		1	36	pc.
60,3 (DN 50)	2457304002		1	24	pc.
76,1 (DN 65)	2457304003		1	12	pc.
88,9 (DN 80)	2457304004		1	15	pc.
114,3 (DN 100)	2457304005		1	6	pc.
139,7 (DN 125)	2457304006		1	4	pc.
168,3 (DN 150)	2457304007		1	2	pc.
219,1 (DN 200)	2457304008		-	1	pc.
273,0 (DN 250)	2457304009		-	1	pc.
323,9 (DN 300)	2457304010		-	1	pc.

coil
 bar
 pipes in tube
 bag
 carton box
 pallet
 new
 available soon

* on request (delivery time up to 4 weeks) | ** availability by individual arrangements | *** till stock ends

Galvanized elbow 22.5°
(2x groove)

7112
GROUP: S

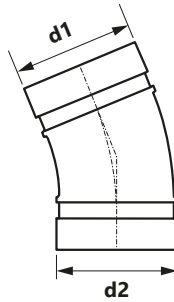

Size (d1 x d2)	Code	*			UM
42,4 (DN 32)	2455304004		1	48	pc.
48,3 (DN 40)	2455304005		1	36	pc.
60,3 (DN 50)	2455304006		1	24	pc.
76,1 (DN 65)	2455304000		1	12	pc.
88,9 (DN 80)	2455304001		1	15	pc.
114,3 (DN 100)	2455304002		1	6	pc.
139,7 (DN 125)	2455304007		1	4	pc.
168,3 (DN 150)	2455304003		1	2	pc.
219,1 (DN 200)	2455304008		-	1	pc.
273,0 (DN 250)	2455304009		-	1	pc.
323,9 (DN 300)	2455304010		-	1	pc.

Orange elbow 11.25°
(2x groove)

7113
GROUP: S

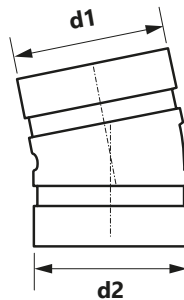

Size (d1 x d2)	Code	*			UM
42,4 (DN 32)	2457316000		1	60	pc.
48,3 (DN 40)	2457316001		1	50	pc.
60,3 (DN 50)	2457316002		1	30	pc.
76,1 (DN 65)	2457316003		1	28	pc.
88,9 (DN 80)	2457316004		1	24	pc.
114,3 (DN 100)	2457316005		1	15	pc.
139,7 (DN 125)	2457316006		1	6	pc.
168,3 (DN 150)	2457316007		1	5	pc.
219,1 (DN 200)	2457316008		1	2	pc.

coil bar pipes in tube bag carton box pallet new available soon

* on request (delivery time up to 4 weeks) | ** availability by individual arrangements | *** till stock ends

Galvanized elbow 11.25°
(2x groove)

7113
GROUP: S

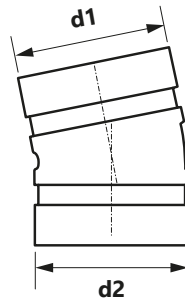

Size (d1 × d2)	Code	*			UM
42,4 (DN 32)	2455316000		1	60	pc.
48,3 (DN 40)	2455316001		1	50	pc.
60,3 (DN 50)	2455316002		1	30	pc.
76,1 (DN 65)	2455316003		1	28	pc.
88,9 (DN 80)	2455316004		1	24	pc.
114,3 (DN 100)	2455316005		1	15	pc.
139,7 (DN 125)	2455316006		1	6	pc.
168,3 (DN 150)	2455316007		1	5	pc.
219,1 (DN 200)	2455316008		1	2	pc.

Orange tee
(3x groove)

7120
GROUP: S

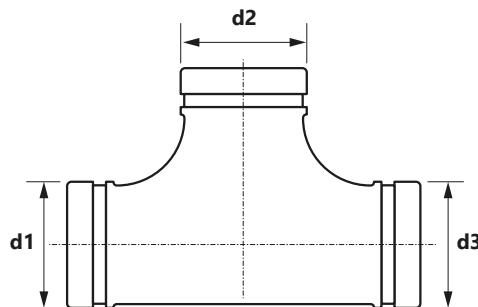

Size (d1 = d2 = d3)	Code	*			UM
33,7 (DN 25)	2457257000		1	40	pc.
42,4 (DN 32)	2457257001		1	20	pc.
48,3 (DN 40)	2457257002		1	15	pc.
60,3 (DN 50)	2457257003		1	16	pc.
76,1 (DN 65)	2457257004		1	10	pc.
88,9 (DN 80)	2457257005		1	5	pc.
114,3 (DN 100)	2457257006		1	3	pc.
139,7 (DN 125)	2457257007		-	1	pc.
168,3 (DN 150)	2457257008		-	1	pc.
219,1 (DN 200)	2457257009		-	1	pc.
273,0 (DN 250)	2457257010		-	1	pc.
323,9 (DN 300)	2457257011		-	1	pc.

coil bar pipes in tube bag carton box pallet new available soon

* on request (delivery time up to 4 weeks) | ** availability by individual arrangements | *** till stock ends

Galvanized tee
(3x groove)

7120
GROUP: S

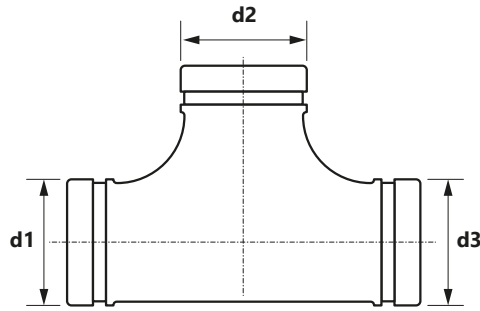

Size (d1=d2=d3)	Code	*			UM
33,7 (DN 25)	2455257001		1	40	pc.
42,4 (DN 32)	2455257002		1	20	pc.
48,3 (DN 40)	2455257003		1	15	pc.
60,3 (DN 50)	2455257004		1	16	pc.
76,1 (DN 65)	2455257005		1	10	pc.
88,9 (DN 80)	2455257006		1	5	pc.
114,3 (DN 100)	2455257007		1	3	pc.
139,7 (DN 125)	2455257008		-	1	pc.
168,3 (DN 150)	2455257000		-	1	pc.
219,1 (DN 200)	2455257009		-	1	pc.
273,0 (DN 250)	2455257010		-	1	pc.
323,9 (DN 300)	2455257011		-	1	pc.

Red short tee
(3x groove)

903
GROUP: S

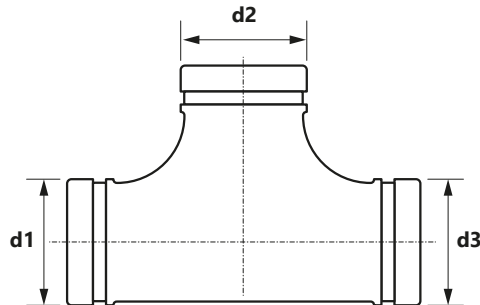

Size (d1=d2=d3)	Code	*			UM
60,3 (DN 50)	2458322000		1	20	pc.
76,1 (DN 65)	2458322001		1	12	pc.
88,9 (DN 80)	2458322002		1	8	pc.
114,3 (DN 100)	2458322003		1	5	pc.
139,7 (DN 125)	2458322004		1	2	pc.
168,3 (DN 150)	2458322005		-	1	pc.
219,1 (DN 200)	2458322006		-	1	pc.

coil bar pipes in tube bag carton box pallet new available soon

* on request (delivery time up to 4 weeks) | ** availability by individual arrangements | *** till stock ends

Galvanized short tee
(3x groove)

903
GROUP: S

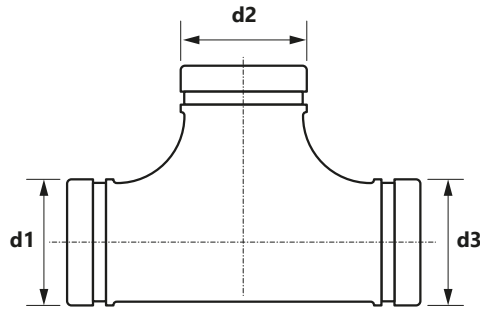

Size (d1=d2=d3)	Code	*			UM
60,3 (DN 50)	2456322000		1	20	pc.
76,1 (DN 65)	2456322001		1	12	pc.
88,9 (DN 80)	2456322002		1	8	pc.
114,3 (DN 100)	2456322003		1	5	pc.
139,7 (DN 125)	2456322004		1	2	pc.
168,3 (DN 150)	2456322005		-	1	pc.
219,1 (DN 200)	2456322006		-	1	pc.

Galvanized arc tee
(2x groove)

7133
GROUP: S

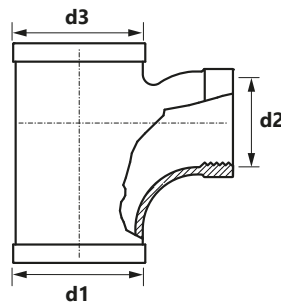

Size (d1=d3×d2)	Code	*			UM
114,3 (DN 100) × Rp2½	2455257012		1	4	pc.

coil bar pipes in tube bag carton box pallet new available soon

* on request (delivery time up to 4 weeks) | ** availability by individual arrangements | *** till stock ends

Male coupling
(groove x outside thread)

59
GROUP: S

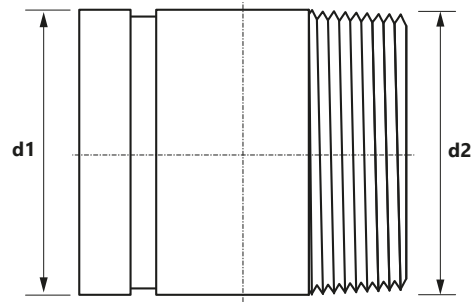

Size (d1 × d2)	Code	*							UM
42,4 (DN 32) × R1¼	2409309000							1 38	pc.
48,3 (DN 40) × R1½	2409309001							1 65	pc.
60,3 (DN 50) × R2	2409309002							1 45	pc.
76,1 (DN 65) × R2½	2409309003							1 25	pc.
88,9 (DN 80) × R3	2409309004							1 20	pc.
114,3 (DN 100) × R4	2409309005							1 6	pc.

coil
 bar
 pipes in tube
 bag
 carton box
 pallet
 new
 available soon

* on request (delivery time up to 4 weeks) | ** availability by individual arrangements | *** till stock ends

Orange reducing tee (3x groove)

7121
GROUP: S

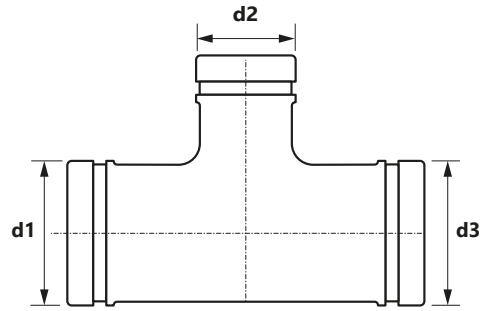

Size (d1 × d2 × d3)	Code	*			UM
60,3 (DN 50) × 33,7 (DN 25) × 60,3 (DN 50)	2457260000		1	20	pc.
60,3 (DN 50) × 48,3 (DN 40) × 60,3 (DN 50)	2457260001		1	16	pc.
76,1 (DN 65) × 60,3 (DN 50) × 76,1 (DN 65)	2457260002		1	10	pc.
88,9 (DN 80) × 33,7 (DN 25) × 88,9 (DN 80)	2457260003		1	8	pc.
88,9 (DN 80) × 48,3 (DN 40) × 88,9 (DN 80)	2457260004		1	8	pc.
88,9 (DN 80) × 60,3 (DN 50) × 88,9 (DN 80)	2457260005		1	6	pc.
88,9 (DN 80) × 76,1 (DN 65) × 88,9 (DN 80)	2457260006		1	6	pc.
114,3 (DN 100) × 48,3 (DN 40) × 114,3 (DN 100)	2457260007		1	3	pc.
114,3 (DN 100) × 60,3 (DN 50) × 114,3 (DN 100)	2457260008		1	3	pc.
114,3 (DN 100) × 76,1 (DN 65) × 114,3 (DN 100)	2457260009		1	3	pc.
114,3 (DN 100) × 88,9 (DN 80) × 114,3 (DN 100)	2457260010		1	3	pc.
139,7 (DN 125) × 76,1 (DN 65) × 139,7 (DN 125)	2457260011		1	2	pc.
139,7 (DN 125) × 88,9 (DN 80) × 139,7 (DN 125)	2457260012		1	2	pc.
139,7 (DN 125) × 114,3 (DN 100) × 139,7 (DN 125)	2457260013		1	2	pc.
168,3 (DN 150) × 60,3 (DN 50) × 168,3 (DN 150)	2457260014		-	1	pc.
168,3 (DN 150) × 88,9 (DN 80) × 168,3 (DN 150)	2457260029		-	1	pc.
168,3 (DN 150) × 114,3 (DN 100) × 168,3 (DN 150)	2457260015		-	1	pc.
219,1 (DN 200) × 60,3 (DN 50) × 219,1 (DN 200)	2457260016		-	1	pc.
219,1 (DN 200) × 114,3 (DN 100) × 219,1 (DN 200)	2457260017		-	1	pc.
219,1 (DN 200) × 168,3 (DN 150) × 219,1 (DN 200)	2457260018		-	1	pc.
273,0 (DN 250) × 60,3 (DN 50) × 273,0 (DN 250)	2457260019		-	1	pc.
273,0 (DN 250) × 88,9 (DN 80) × 273,0 (DN 250)	2457260020		-	1	pc.
273,0 (DN 250) × 114,3 (DN 100) × 273,0 (DN 250)	2457260021		-	1	pc.
273,0 (DN 250) × 168,3 (DN 150) × 273,0 (DN 250)	2457260022		-	1	pc.
273,0 (DN 250) × 219,1 (DN 200) × 273,0 (DN 250)	2457260023		-	1	pc.
323,9 (DN 300) × 88,9 (DN 80) × 323,9 (DN 300)	2457260024		-	1	pc.
323,9 (DN 300) × 114,3 (DN 100) × 323,9 (DN 300)	2457260025		-	1	pc.
323,9 (DN 300) × 168,3 (DN 150) × 323,9 (DN 300)	2457260026		-	1	pc.
323,9 (DN 300) × 219,1 (DN 200) × 323,9 (DN 300)	2457260027		-	1	pc.
323,9 (DN 300) × 273,0 (DN 250) × 323,9 (DN 300)	2457260028		-	1	pc.



coil
 bar
 pipes in tube
 bag
 carton box
 pallet
 new
 available soon

* on request (delivery time up to 4 weeks) | ** availability by individual arrangements | *** till stock ends

Galvanized reducing tee (3x groove)

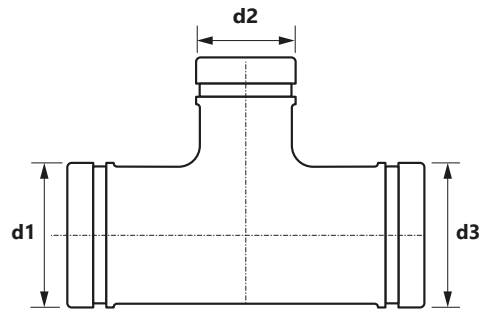
7121
GROUP: S



Size (d1 × d2 × d3)	Code	*			UM
60,3 (DN 50) × 33,7 (DN 25) × 60,3 (DN 50)	2455260002		1	20	pc.
60,3 (DN 50) × 48,3 (DN 40) × 60,3 (DN 50)	2455260003		1	16	pc.
76,1 (DN 65) × 60,3 (DN 50) × 76,1 (DN 65)	2455260004		1	10	pc.
88,9 (DN 80) × 33,7 (DN 25) × 88,9 (DN 80)	2455260005		1	8	pc.
88,9 (DN 80) × 48,3 (DN 40) × 88,9 (DN 80)	2455260006		1	8	pc.
88,9 (DN 80) × 60,3 (DN 50) × 88,9 (DN 80)	2455260007		1	6	pc.
88,9 (DN 80) × 76,1 (DN 65) × 88,9 (DN 80)	2455260008		1	6	pc.
114,3 (DN 100) × 60,3 (DN 50) × 114,3 (DN 100)	2455260000		1	3	pc.
114,3 (DN 100) × 76,1 (DN 65) × 114,3 (DN 100)	2455260009		1	3	pc.
114,3 (DN 100) × 88,9 (DN 80) × 114,3 (DN 100)	2455260010		1	3	pc.
139,7 (DN 125) × 76,1 (DN 65) × 139,7 (DN 125)	2455260011		1	2	pc.
139,7 (DN 125) × 88,9 (DN 80) × 139,7 (DN 125)	2455260012		1	2	pc.
139,7 (DN 125) × 114,3 (DN 100) × 139,7 (DN 125)	2455260013		1	2	pc.
168,3 (DN 150) × 60,3 (DN 50) × 168,3 (DN 150)	2455260014		-	1	pc.
168,3 (DN 150) × 114,3 (DN 100) × 168,3 (DN 150)	2455260001		-	1	pc.
219,1 (DN 200) × 60,3 (DN 50) × 219,1 (DN 200)	2455260015		-	1	pc.
219,1 (DN 200) × 114,3 (DN 100) × 219,1 (DN 200)	2455260016		-	1	pc.
219,1 (DN 200) × 168,3 (DN 150) × 219,1 (DN 200)	2455260017		-	1	pc.
273,0 (DN 250) × 88,9 (DN 80) × 273,0 (DN 250)	2455260018		-	1	pc.
273,0 (DN 250) × 114,3 (DN 100) × 273,0 (DN 250)	2455260019		-	1	pc.
273,0 (DN 250) × 168,3 (DN 150) × 273,0 (DN 250)	2455260020		-	1	pc.
273,0 (DN 250) × 219,1 (DN 200) × 273,0 (DN 250)	2455260021		-	1	pc.
323,9 (DN 300) × 219,1 (DN 200) × 323,9 (DN 300)	2455260022		-	1	pc.
323,9 (DN 300) × 273,0 (DN 250) × 323,9 (DN 300)	2455260023		-	1	pc.

 coil
  bar
  pipes in tube
  bag
  carton box
  pallet
  new
  available soon

* on request (delivery time up to 4 weeks) | ** availability by individual arrangements | *** till stock ends

Orange concentric reducer (2x groove)

7150
GROUP: S

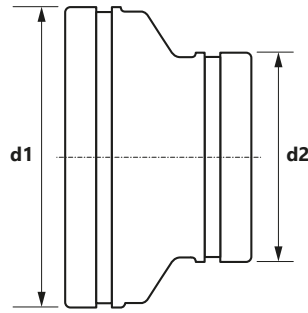

Size (d1 × d2)	Code	*			UM
42,4 (DN 32) × 33,7 (DN 25)	2457305000		1	90	pc.
48,3 (DN 40) × 33,7 (DN 25)	2457305001		1	80	pc.
48,3 (DN 40) × 42,4 (DN 32)	2457305002		1	50	pc.
60,3 (DN 50) × 33,7 (DN 25)	2457305003		1	50	pc.
60,3 (DN 50) × 42,4 (DN 32)	2457305004		1	50	pc.
60,3 (DN 50) × 48,3 (DN 40)	2457305005		1	36	pc.
76,1 (DN 65) × 42,4 (DN 32)	2457305006		1	28	pc.
76,1 (DN 65) × 48,3 (DN 40)	2457305008		1	28	pc.
76,1 (DN 65) × 60,3 (DN 50)	2457305007		1	24	pc.
88,9 (DN 80) × 42,4 (DN 32)	2457305009		1	24	pc.
88,9 (DN 80) × 48,3 (DN 40)	2457305010		1	24	pc.
88,9 (DN 80) × 60,3 (DN 50)	2457305011		1	24	pc.
88,9 (DN 80) × 76,1 (DN 65)	2457305012		1	18	pc.
114,3 (DN 100) × 48,3 (DN 40)	2457305013		1	12	pc.
114,3 (DN 100) × 60,3 (DN 50)	2457305014		1	24	pc.
114,3 (DN 100) × 76,1 (DN 65)	2457305015		1	20	pc.
114,3 (DN 100) × 88,9 (DN 80)	2457305016		1	20	pc.
139,7 (DN 125) × 88,9 (DN 80)	2457305017		1	12	pc.
139,7 (DN 125) × 114,3 (DN 100)	2457305018		1	12	pc.
168,3 (DN 150) × 60,3 (DN 50)	2457305019		1	8	pc.
168,3 (DN 150) × 88,9 (DN 80)	2457305020		1	8	pc.
168,3 (DN 150) × 114,3 (DN 100)	2457305021		1	8	pc.
168,3 (DN 150) × 139,7 (DN 125)	2457305022		1	8	pc.
219,1 (DN 200) × 114,3 (DN 100)	2457305023		1	3	pc.
219,1 (DN 200) × 168,3 (DN 150)	2457305024		1	3	pc.
273,0 (DN 250) × 114,3 (DN 100)	2457305025		-	1	pc.
273,0 (DN 250) × 168,3 (DN 150)	2457305026		-	1	pc.
273,0 (DN 250) × 219,1 (DN 200)	2457305027		-	1	pc.
323,9 (DN 300) × 168,3 (DN 150)	2457305028		-	1	pc.
323,9 (DN 300) × 219,1 (DN 200)	2457305029		-	1	pc.
323,9 (DN 300) × 273,0 (DN 250)	2457305030		-	1	pc.

coil bar pipes in tube bag carton box pallet new available soon

* on request (delivery time up to 4 weeks) | ** availability by individual arrangements | *** till stock ends

Galvanized concentric reducer
(2x groove)

7150
GROUP: S

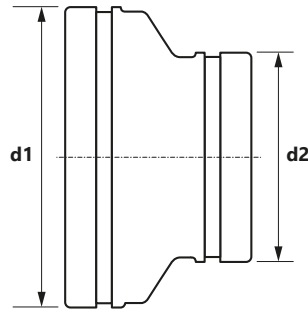

Size (d1 × d2)	Code	*				UM
42,4 (DN 32) × 33,7 (DN 25)	2455305002		1		90	pc.
48,3 (DN 40) × 33,7 (DN 25)	2455305003		1		80	pc.
48,3 (DN 40) × 42,4 (DN 32)	2455305000		1		50	pc.
60,3 (DN 50) × 33,7 (DN 25)	2455305004		1		50	pc.
60,3 (DN 50) × 42,4 (DN 32)	2455305005		1		50	pc.
60,3 (DN 50) × 48,3 (DN 40)	2455305001		1		36	pc.
76,1 (DN 65) × 42,4 (DN 32)	2455305006		1		28	pc.
76,1 (DN 65) × 48,3 (DN 40)	2455305007		1		28	pc.
76,1 (DN 65) × 60,3 (DN 50)	2455305008		1		24	pc.
88,9 (DN 80) × 48,3 (DN 40)	2455305009		1		24	pc.
88,9 (DN 80) × 60,3 (DN 50)	2455305010		1		24	pc.
88,9 (DN 80) × 76,1 (DN 65)	2455305011		1		18	pc.
114,3 (DN 100) × 60,3 (DN 50)	2455305012		1		24	pc.
114,3 (DN 100) × 76,1 (DN 65)	2455305013		1		20	pc.
114,3 (DN 100) × 88,9 (DN 80)	2455305014		1		20	pc.
139,7 (DN 125) × 88,9 (DN 80)	2455305015		1		12	pc.
139,7 (DN 125) × 114,3 (DN 100)	2455305016		1		12	pc.
168,3 (DN 150) × 60,3 (DN 50)	2455305017		1		8	pc.
168,3 (DN 150) × 76,1 (DN 65)	2455305018		1		8	pc.
168,3 (DN 150) × 88,9 (DN 80)	2455305019		1		8	pc.
168,3 (DN 150) × 114,3 (DN 100)	2455305020		1		8	pc.
168,3 (DN 150) × 139,7 (DN 125)	2455305021		1		8	pc.
219,1 (DN 200) × 114,3 (DN 100)	2455305022		1		3	pc.
219,1 (DN 200) × 168,3 (DN 150)	2455305023		1		3	pc.
273,0 (DN 250) × 114,3 (DN 100)	2455305024		-		1	pc.
273,0 (DN 250) × 168,3 (DN 150)	2455305025		-		1	pc.
273,0 (DN 250) × 219,1 (DN 200)	2455305026		-		1	pc.
323,9 (DN 300) × 219,1 (DN 200)	2455305027		-		1	pc.
323,9 (DN 300) × 273,0 (DN 250)	2455305028		-		1	pc.

coil bar pipes in tube bag carton box pallet new available soon

* on request (delivery time up to 4 weeks) | ** availability by individual arrangements | *** till stock ends

Orange eccentric reducer
(2x groove)

7151
GROUP: S

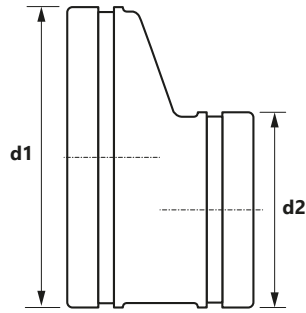

Size (d1 × d2)	Code	*			UM
76,1 (DN 65) × 60,3 (DN 50)	2457319000		1	16	pc.
88,9 (DN 80) × 60,3 (DN 50)	2457319001		1	18	pc.
88,9 (DN 80) × 76,1 (DN 65)	2457319002		1	12	pc.
114,3 (DN 100) × 60,3 (DN 50)	2457319003		1	12	pc.
114,3 (DN 100) × 76,1 (DN 65)	2457319004		1	12	pc.
114,3 (DN 100) × 88,9 (DN 80)	2457319005		1	12	pc.
139,7 (DN 125) × 88,9 (DN 80)	2457319006		1	4	pc.
139,7 (DN 125) × 114,3 (DN 100)	2457319007		1	4	pc.
168,3 (DN 150) × 60,3 (DN 50)	2457319008		1	7	pc.
168,3 (DN 150) × 88,9 (DN 80)	2457319009		1	4	pc.
168,3 (DN 150) × 114,3 (DN 100)	2457319010		1	7	pc.
219,1 (DN 200) × 114,3 (DN 100)	2457319011		1	3	pc.
219,1 (DN 200) × 168,3 (DN 150)	2457319012		1	2	pc.
273,0 (DN 250) × 219,1 (DN 200)	2457319013		-	1	pc.
323,9 (DN 300) × 219,1 (DN 200)	2457319014		-	1	pc.

Galvanized eccentric reducer
(2x groove)

7151
GROUP: S

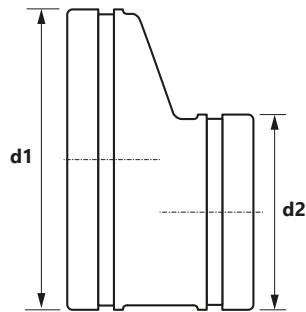

Size (d1 × d2)	Code	*			UM
76,1 (DN 65) × 60,3 (DN 50)	2455319000		1	16	pc.
88,9 (DN 80) × 60,3 (DN 50)	2455319001		1	18	pc.
88,9 (DN 80) × 76,1 (DN 65)	2455319002		1	12	pc.
114,3 (DN 100) × 60,3 (DN 50)	2455319003		1	12	pc.
114,3 (DN 100) × 76,1 (DN 65)	2455319004		1	12	pc.
114,3 (DN 100) × 88,9 (DN 80)	2455319005		1	12	pc.
168,3 (DN 150) × 88,9 (DN 80)	2455319006		1	4	pc.
168,3 (DN 150) × 114,3 (DN 100)	2455319007		1	7	pc.
219,1 (DN 200) × 168,3 (DN 150)	2455319008		1	2	pc.
273,0 (DN 250) × 219,1 (DN 200)	2455319009		-	1	pc.

coil bar pipes in tube bag carton box pallet new available soon

* on request (delivery time up to 4 weeks) | ** availability by individual arrangements | *** till stock ends

Red stop end
(grooved)

7160
GROUP: S

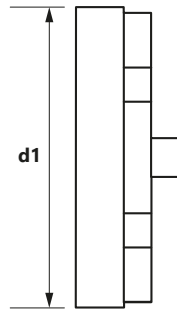

Size (d1)	Code	*							UM
33,7 (DN 25)	2457025000						1	220	pc.
42,4 (DN 32)	2457025001						1	145	pc.
48,3 (DN 40)	2457025002						1	110	pc.
60,3 (DN 50)	2457025003						1	75	pc.
76,1 (DN 65)	2457025004						1	50	pc.
88,9 (DN 80)	2457025005						1	30	pc.
114,3 (DN 100)	2457025006						1	18	pc.
139,7 (DN 125)	2457025007						1	12	pc.
168,3 (DN 150)	2457025008						1	8	pc.
219,1 (DN 200)	2457025009						1	3	pc.
273,0 (DN 250)	2457025010						1	3	pc.
323,9 (DN 300)	2457025011						-	1	pc.

Galvanized stop end
(grooved)

7160
GROUP: S

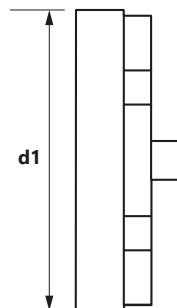

Size (d1)	Code	*							UM
33,7 (DN25)	2455025000						1	220	pc.
42,4 (DN 32)	2455025001						1	145	pc.
48,3 (DN 40)	2455025002						1	110	pc.
60,3 (DN 50)	2455025003						1	75	pc.
76,1 (DN 65)	2455025004						1	50	pc.
88,9 (DN 80)	2455025005						1	30	pc.
114,3 (DN 100)	2455025006						1	18	pc.
139,7 (DN 125)	2455025007						1	12	pc.
168,3 (DN 150)	2455025008						1	8	pc.
219,1 (DN 200)	2455025009						1	3	pc.
273,0 (DN 250)	2455025010						1	3	pc.
323,9 (DN 300)	2455025011						-	1	pc.

coil bar pipes in tube bag carton box pallet new available soon

* on request (delivery time up to 4 weeks) | ** availability by individual arrangements | *** till stock ends

Red female transition fitting
(groove x inside thread)

7160T
GROUP: S

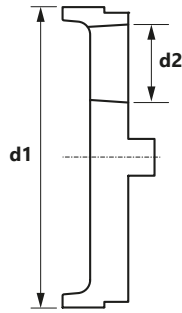

Size (d1 × d2)	Code	*			UM
60,3 (DN 50) × Rp1	2457320000		1	75	pc.
76,1 (DN 65) × Rp1	2457320001		1	50	pc.
76,1 (DN 65) × Rp1¼	2457320002		1	50	pc.
76,1 (DN 65) × Rp1½	2457320003		1	50	pc.
88,9 (DN 80) × Rp1	2457320004		1	30	pc.
88,9 (DN 80) × Rp1¼	2457320005		1	30	pc.
88,9 (DN 80) × Rp1½	2457320006		1	30	pc.
114,3 (DN 100) × Rp1	2457320007		1	18	pc.
114,3 (DN 100) × Rp1¼	2457320008		1	18	pc.
114,3 (DN 100) × Rp1½	2457320009		1	18	pc.
114,3 (DN 100) × Rp2	2457320010		1	18	pc.
139,7 (DN 125) × Rp2	2457320011		1	12	pc.
168,3 (DN 150) × Rp2	2457320012		1	8	pc.
219,1 (DN 200) × Rp2	2457320013		1	3	pc.

Galvanized female transition fitting
(groove x inside thread)

7160T
GROUP: S

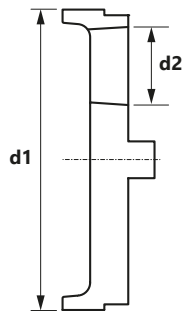

Size (d1 × d2)	Code	*			UM
60,3 (DN 50) × Rp1	2455320000		1	75	pc.
76,1 (DN 65) × Rp1	2455320001		1	50	pc.
88,9 (DN 80) × Rp2	2455320002		1	30	pc.
114,3 (DN 100) × Rp1	2455320003		1	18	pc.
114,3 (DN 100) × Rp1½	2455320004		1	18	pc.
114,3 (DN 100) × Rp2	2455320005		1	18	pc.
139,7 (DN 125) × Rp2	2455320006		1	12	pc.
168,3 (DN 150) × Rp2	2455320007		1	8	pc.

coil bar pipes in tube bag carton box pallet new available soon

* on request (delivery time up to 4 weeks) | ** availability by individual arrangements | *** till stock ends

Orange universal flange
(PN 10/16, ANSI Class 125/150, BS10E)

7180
GROUP: S

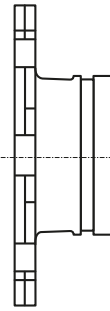
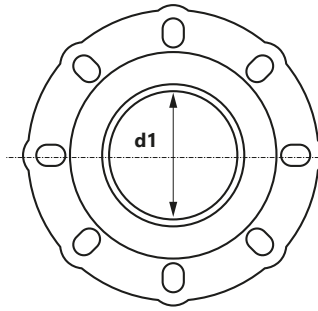

Size (d1)	Code	*			UM
60,3 (DN 50)	2457315000		1	4	pc.
76,1 (DN 65)	2457315001		1	3	pc.
88,9 (DN 80)	2457315002		1	6	pc.
114,3 (DN 100)	2457315003		1	4	pc.
139,7 (DN 125)	2457315004		1	2	pc.
168,3 (DN 150)	2457315005		1	2	pc.
219,1 (DN 200)	2457315006		-	1	pc.

Galvanized universal flange
(PN 10/16, ANSI Class 125/150, BS10E)

7180
GROUP: S

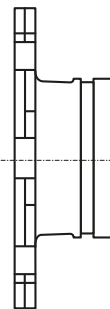
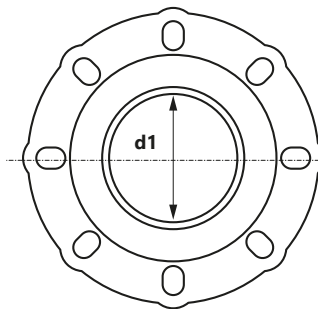

Size (d1)	Code	*			UM
60,3 (DN 50)	2455315000		1	4	pc.
76,1 (DN 65)	2455315001		1	3	pc.
88,9 (DN 80)	2455315002		1	6	pc.
114,3 (DN 100)	2455315003		1	4	pc.
139,7 (DN 125)	2455315004		1	2	pc.
168,3 (DN 150)	2455315005		1	2	pc.
219,1 (DN 200)	2455315006		-	1	pc.

coil bar pipes in tube bag carton box pallet new available soon

* on request (delivery time up to 4 weeks) | ** availability by individual arrangements | *** till stock ends

Red female mechanical tee 
 (Outlet with internal thread ISO R7, with class E gasket)

7721
GROUP: S

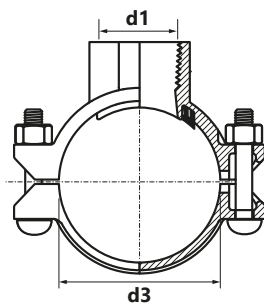

Size (d3×d1)	Code	*			UM
60,3 (DN 50) × Rp1/2	2457317000		1	10	pc.
60,3 (DN 50) × Rp3/4	2457317001		1	10	pc.
60,3 (DN 50) × Rp1	2457317002		1	10	pc.
60,3 (DN 50) × Rp1 1/4	2457317003		1	8	pc.
60,3 (DN 50) × Rp1 1/2	2457317004		1	8	pc.
76,1 (DN 65) × Rp1/2	2457317005		1	7	pc.
76,1 (DN 65) × Rp3/4	2457317006		1	7	pc.
76,1 (DN 65) × Rp1	2457317007		1	7	pc.
76,1 (DN 65) × Rp1 1/4	2457317008		1	7	pc.
76,1 (DN 65) × Rp1 1/2	2457317009		1	6	pc.
88,9 (DN 80) × Rp1/2	2457317010		1	7	pc.
88,9 (DN 80) × Rp3/4	2457317011		1	7	pc.
88,9 (DN 80) × Rp1	2457317012		1	7	pc.
88,9 (DN 80) × Rp1 1/4	2457317013		1	10	pc.
88,9 (DN 80) × Rp1 1/2	2457317014		1	6	pc.
88,9 (DN 80) × Rp2	2457317015		1	5	pc.
114,3 (DN 100) × Rp1/2	2457317016		1	12	pc.
114,3 (DN 100) × Rp3/4	2457317017		1	12	pc.
114,3 (DN 100) × Rp1	2457317018		1	5	pc.
114,3 (DN 100) × Rp1 1/4	2457317019		1	4	pc.
114,3 (DN 100) × Rp1 1/2	2457317020		1	8	pc.
114,3 (DN 100) × Rp2	2457317021		1	8	pc.
114,3 (DN 100) × Rp2 1/2	2457317022		1	5	pc.
114,3 (DN 100) × Rp3	2457317023		1	3	pc.
168,3 (DN 150) × Rp1 1/4	2457317024		1	4	pc.
168,3 (DN 150) × Rp1 1/2	2457317025		1	4	pc.
168,3 (DN 150) × Rp2	2457317026		1	4	pc.
168,3 (DN 150) × Rp2 1/2	2457317027		1	3	pc.
168,3 (DN 150) × Rp3	2457317028		1	3	pc.
219,1 (DN 200) × Rp2	2457317029		1	2	pc.
219,1 (DN 200) × Rp2 1/2	2457317030		1	2	pc.
219,1 (DN 200) × Rp3	2457317031		1	2	pc.



 coil  bar  pipes in tube  bag  carton box  pallet  new  available soon

* on request (delivery time up to 4 weeks) | ** availability by individual arrangements | *** till stock ends

Galvanized female mechanical tee 
 (Outlet with internal thread ISO R7, with class E gasket)

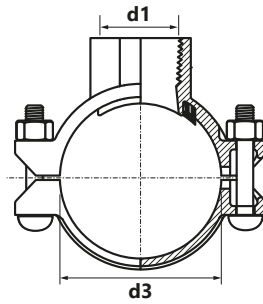
7721
GROUP: S



Size (d3×d1)	Code	*			UM
60,3 (DN 50) × Rp1/2	2455317000		1	10	pc.
60,3 (DN 50) × Rp3/4	2455317001		1	10	pc.
60,3 (DN 50) × Rp1	2455317002		1	10	pc.
60,3 (DN 50) × Rp1 1/4	2455317003		1	8	pc.
60,3 (DN 50) × Rp1 1/2	2455317004		1	8	pc.
76,1 (DN 65) × Rp1/2	2455317005		1	7	pc.
76,1 (DN 65) × Rp3/4	2455317006		1	7	pc.
76,1 (DN 65) × Rp1	2455317007		1	7	pc.
76,1 (DN 65) × Rp1 1/4	2455317008		1	7	pc.
76,1 (DN 65) × Rp1 1/2	2455317009		1	6	pc.
88,9 (DN 80) × Rp1/2	2455317010		1	7	pc.
88,9 (DN 80) × Rp3/4	2455317011		1	7	pc.
88,9 (DN 80) × Rp1	2455317012		1	7	pc.
88,9 (DN 80) × Rp1 1/4	2455317013		1	10	pc.
88,9 (DN 80) × Rp1 1/2	2455317014		1	6	pc.
88,9 (DN 80) × Rp2	2455317015		1	5	pc.
114,3 (DN 100) × Rp1/2	2455317016		1	12	pc.
114,3 (DN 100) × Rp3/4	2455317017		1	12	pc.
114,3 (DN 100) × Rp1	2455317018		1	5	pc.
114,3 (DN 100) × Rp1 1/4	2455317019		1	4	pc.
114,3 (DN 100) × Rp1 1/2	2455317020		1	8	pc.
114,3 (DN 100) × Rp2	2455317021		1	8	pc.
114,3 (DN 100) × Rp2 1/2	2455317022		1	5	pc.
114,3 (DN 100) × Rp3	2455317023		1	3	pc.
168,3 (DN 150) × Rp1 1/4	2455317024		1	4	pc.
168,3 (DN 150) × Rp1 1/2	2455317025		1	4	pc.
168,3 (DN 150) × Rp2	2455317026		1	4	pc.
168,3 (DN 150) × Rp2 1/2	2455317027		1	3	pc.
168,3 (DN 150) × Rp3	2455317028		1	3	pc.
219,1 (DN 200) × Rp2	2455317029		1	2	pc.
219,1 (DN 200) × Rp2 1/2	2455317030		1	2	pc.
219,1 (DN 200) × Rp3	2455317031		1	2	pc.

 coil  bar  pipes in tube  bag  carton box  pallet  new  available soon

* on request (delivery time up to 4 weeks) | ** availability by individual arrangements | *** till stock ends

Red mechanical tee (T)
(grooved end of the outlet with class E gasket)

7722
GROUP: S

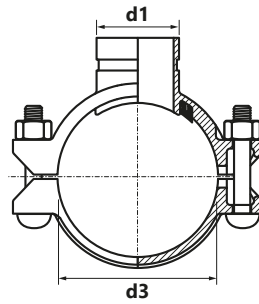

Size (d3×d1)	Code	*			UM
60,3 (DN 50) × 42,4 (DN 32)	2457318000		1	10	pc.
60,3 (DN 50) × 48,3 (DN 40)	2457318001		1	10	pc.
76,1 (DN 65) × 42,4 (DN 32)	2457318002		1	7	pc.
76,1 (DN 65) × 48,3 (DN 40)	2457318003		1	6	pc.
88,9 (DN 80) × 42,4 (DN 32)	2457318004		1	10	pc.
88,9 (DN 80) × 48,3 (DN 40)	2457318005		1	10	pc.
88,9 (DN 80) × 60,3 (DN 50)	2457318006		1	10	pc.
114,3 (DN 100) × 33,4 (DN 25)	2457318024		-	1	pc.
114,3 (DN 100) × 42,4 (DN 32)	2457318007		1	8	pc.
114,3 (DN 100) × 48,3 (DN 40)	2457318008		1	8	pc.
114,3 (DN 100) × 60,3 (DN 50)	2457318009		1	8	pc.
114,3 (DN 100) × 76,1 (DN 65)	2457318010		1	5	pc.
114,3 (DN 100) × 88,9 (DN 80)	2457318011		1	3	pc.
139,7 (DN 125) × 60,3 (DN 50)	2457318012		1	4	pc.
139,7 (DN 125) × 76,1 (DN 65)	2457318013		1	4	pc.
168,3 (DN 150) × 42,4 (DN 32)	2457318014		1	4	pc.
168,3 (DN 150) × 48,3 (DN 40)	2457318015		1	4	pc.
168,3 (DN 150) × 60,3 (DN 50)	2457318016		1	4	pc.
168,3 (DN 150) × 76,1 (DN 65)	2457318017		1	3	pc.
168,3 (DN 150) × 88,9 (DN 80)	2457318018		1	2	pc.
168,3 (DN 150) × 114,3 (DN 100)	2457318019		1	2	pc.
219,1 (DN 200) × 60,3 (DN 50)	2457318020		1	2	pc.
219,1 (DN 200) × 76,1 (DN 65)	2457318021		1	2	pc.
219,1 (DN 200) × 88,9 (DN 80)	2457318022		1	2	pc.
219,1 (DN 200) × 114,3 (DN 100)	2457318023		1	2	pc.



coil bar pipes in tube bag carton box pallet new available soon

* on request (delivery time up to 4 weeks) | ** availability by individual arrangements | *** till stock ends

Galvanized mechanical tee 
(grooved end of the outlet with class E gasket)

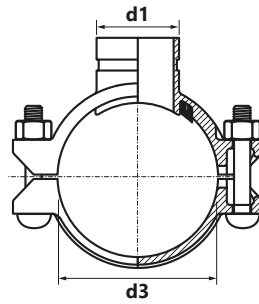
7722
GROUP: S



Size (d3×d1)	Code	*			UM
60,3 (DN 50) × 42,4 (DN 32)	2455318000		1	10	pc.
60,3 (DN 50) × 48,3 (DN 40)	2455318001		1	10	pc.
76,1 (DN 65) × 42,4 (DN 32)	2455318002		1	7	pc.
76,1 (DN 65) × 48,3 (DN 40)	2455318003		1	6	pc.
88,9 (DN 80) × 42,4 (DN 32)	2455318004		1	10	pc.
88,9 (DN 80) × 48,3 (DN 40)	2455318005		1	10	pc.
88,9 (DN 80) × 60,3 (DN 50)	2455318006		1	10	pc.
114,3 (DN 100) × 42,4 (DN 32)	2455318007		1	8	pc.
114,3 (DN 100) × 48,3 (DN 40)	2455318008		1	8	pc.
114,3 (DN 100) × 60,3 (DN 50)	2455318009		1	8	pc.
114,3 (DN 100) × 76,1 (DN 65)	2455318010		1	5	pc.
114,3 (DN 100) × 88,9 (DN 80)	2455318011		1	3	pc.
168,3 (DN 150) × 42,4 (DN 32)	2455318012		1	4	pc.
168,3 (DN 150) × 48,3 (DN 40)	2455318013		1	4	pc.
168,3 (DN 150) × 60,3 (DN 50)	2455318014		1	4	pc.
168,3 (DN 150) × 76,1 (DN 65)	2455318015		1	3	pc.
168,3 (DN 150) × 88,9 (DN 80)	2455318016		1	2	pc.
168,3 (DN 150) × 114,3 (DN 100)	2455318017		1	2	pc.
219,1 (DN 200) × 60,3 (DN 50)	2455318018		1	2	pc.
219,1 (DN 200) × 76,1 (DN 65)	2455318019		1	2	pc.
219,1 (DN 200) × 88,9 (DN 80)	2455318020		1	2	pc.
219,1 (DN 200) × 114,3 (DN 100)	2455318021		1	2	pc.

 coil  bar  pipes in tube  bag  carton box  pallet  new  available soon

* on request (delivery time up to 4 weeks) | ** availability by individual arrangements | *** till stock ends

Red female saddle (T)
(with class E gasket)

723
GROUP: S

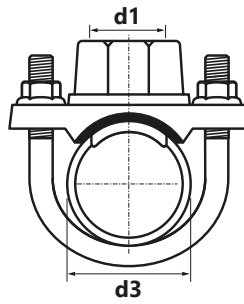

Size (d3×d1)	Code	*			UM
42,4 (DN 32) × Rp1/2	2458230000		1	35	pc.
42,4 (DN 32) × Rp3/4	2458230001		1	35	pc.
42,4 (DN 32) × Rp1	2458230002		1	35	pc.
48,3 (DN 40) × Rp1/2	2458230003		1	35	pc.
48,3 (DN 40) × Rp3/4	2458230004		1	35	pc.
48,3 (DN 40) × Rp1	2458230005		1	35	pc.
60,3 (DN 50) × Rp1/2	2458230006		1	35	pc.
60,3 (DN 50) × Rp3/4	2458230007		1	35	pc.
60,3 (DN 50) × Rp1	2458230008		1	35	pc.
76,1 (DN 65) × Rp1/2	2458230009		1	28	pc.
76,1 (DN 65) × Rp3/4	2458230010		1	28	pc.
76,1 (DN 65) × Rp1	2458230011		1	28	pc.

Galvanized female saddle (T)
(with class E gasket)

723
GROUP: S

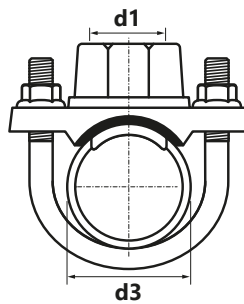

Size (d3×d1)	Code	*			UM
42,4 (DN 32) × Rp1/2	2456230000		1	35	pc.
42,4 (DN 32) × Rp3/4	2456230001		1	35	pc.
42,4 (DN 32) × Rp1	2456230002		1	35	pc.
48,3 (DN 40) × Rp1/2	2456230003		1	35	pc.
48,3 (DN 40) × Rp3/4	2456230004		1	35	pc.
48,3 (DN 40) × Rp1	2456230005		1	35	pc.
60,3 (DN 50) × Rp1/2	2456230006		1	35	pc.
60,3 (DN 50) × Rp3/4	2456230007		1	35	pc.
60,3 (DN 50) × Rp1	2456230008		1	35	pc.
76,1 (DN 65) × Rp1/2	2456230009		1	28	pc.
76,1 (DN 65) × Rp3/4	2456230010		1	28	pc.
76,1 (DN 65) × Rp1	2456230011		1	28	pc.

coil bar pipes in tube bag carton box pallet new available soon

* on request (delivery time up to 4 weeks) | ** availability by individual arrangements | *** till stock ends

Coated throttle valve

(2x groove, with handle of lever and disc covered with EPDM coating)

SJ-300N-L
GROUP: S

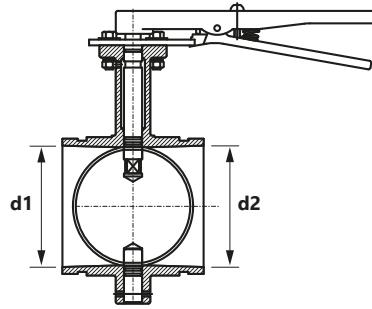

Size (d1=d2)	Code	*			UM
60,3 (DN 50)	2409310000		1	2	pc.
76,1 (DN 65)	2409310001		1	2	pc.
88,9 (DN 80)	2409310002		1	2	pc.
114,3 (DN 100)	2409310003		1	2	pc.
139,7 (DN 125)	2409310004		1	2	pc.
168,3 (DN 150)	2409310005		1	2	pc.
219,1 (DN 200)	2409310006		-	1	pc.

Coated throttle valve with gear

(2x groove, with handle of lever and disc covered with EPDM coating)

SJ-300N-W
GROUP: S

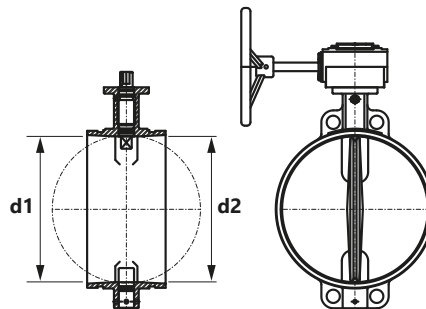

Size (d1=d2)	Code	*			UM
168,3 (DN 150)	2409311000		1	2	pc.
219,1 (DN 200)	2409311001		-	1	pc.
273,0 (DN 250)	2409311002		-	1	pc.
323,9 (DN 300)	2409311003		-	1	pc.

coil
 bar
 pipes in tube
 bag
 carton box
 pallet
 new
 available soon

* on request (delivery time up to 4 weeks) | ** availability by individual arrangements | *** till stock ends

Carbon steel ball valve Groove
(2x groove)

SJ-500-L
GROUP: S

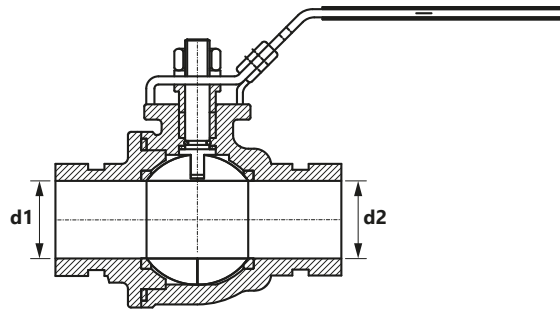

Size (d1=d2)	Code	*			UM
48,3 (DN 40)	2409278000		1	10	pc.
60,3 (DN 50)	2409278001		1	5	pc.
76,1 (DN 65)	2409278002		1	3	pc.
88,9 (DN 80)	2409278003		1	2	pc.

Stainless steel ball valve
(2x groove)

SJ-500-L
GROUP: S

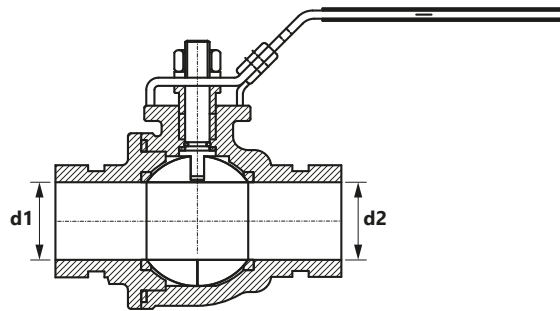

Size (d1=d2)	Code	*			UM
48,3 (DN 40)	2409278004		1	10	pc.
60,3 (DN 50)	2409278005		1	5	pc.
76,1 (DN 65)	2409278006		1	3	pc.
88,9 (DN 80)	2409278007		1	2	pc.

coil bar pipes in tube bag carton box pallet new available soon

* on request (delivery time up to 4 weeks) | ** availability by individual arrangements | *** till stock ends

Coated swing check valve
(2x groove)

SJ-900
GROUP: S

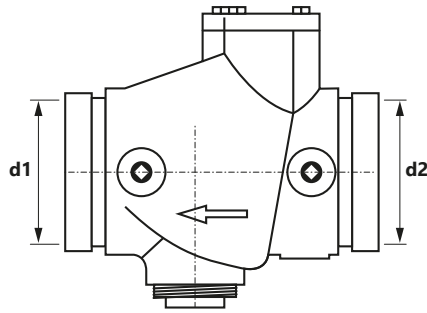

Size (d1=d2)	Code	*			UM
76,1 (DN 65)	2409308000		1	4	pc.
88,9 (DN 80)	2409308001		1	4	pc.
114,3 (DN 100)	2409308002		1	2	pc.
139,7 (DN 125)	2409308003		-	1	pc.
168,3 (DN 150)	2409308004		-	1	pc.
219,1 (DN 200)	2409308005		-	1	pc.
273,0 (DN 250)	2409308006		-	1	pc.
323,9 (DN 300)	2409308007		-	1	pc.

Orange suction diffuser
(2x groove)

725G
GROUP: S

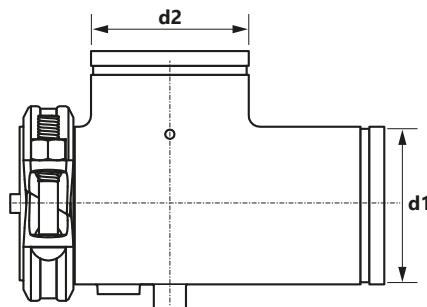

Size (d1=d2)	Code	*			UM
76,1 (DN 65)	2457324000		1	4	pc.
88,9 (DN 80)	2457324001		1	3	pc.
114,3 (DN 100)	2457324002		-	1	pc.
168,3 (DN 150)	2457324003		-	1	pc.
219,1 (DN 200)	2457324004		-	1	pc.
273,0 (DN 250)	2457324005		-	1	pc.



coil bar pipes in tube bag carton box pallet new available soon

* on request (delivery time up to 4 weeks) | ** availability by individual arrangements | *** till stock ends

Orange Y type strainer
(3x groove)

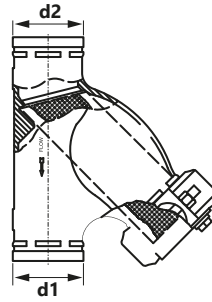
726
GROUP: S



Size (d1=d2)	Code	*			UM
60,3 (DN 50)	2457086000		1	4	pc.
76,1 (DN 65)	2457086001		1	3	pc.
88,9 (DN 80)	2457086002		1	2	pc.
114,3 (DN 100)	2457086003		-	1	pc.
139,7 (DN 125)	2457086004		-	1	pc.
168,3 (DN 150)	2457086005		-	1	pc.
219,1 (DN 200)	2457086006		-	1	pc.
273,0 (DN 250)	2457086007		-	1	pc.

 coil
  bar
  pipes in tube
  bag
  carton box
  pallet
  new
  available soon

* on request (delivery time up to 4 weeks) | ** availability by individual arrangements | *** till stock ends



Accessories

EPDM "C" type gasket

(for Z05, Z07, 7707, 7705 couplings)

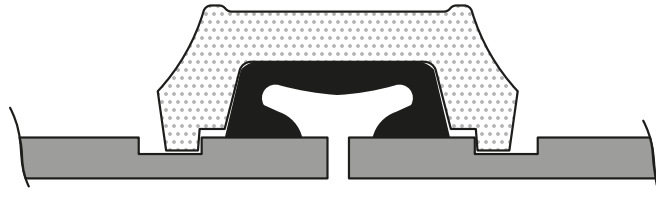
GROUP: S



Size	Code	*			UM
33,7 (DN 25)	2409237009		1	300	pc.
42,4 (DN 32)	2409237010		1	210	pc.
48,3 (DN 40)	2409237011		1	170	pc.
60,3 (DN 50)	2409237012		1	120	pc.
76,1 (DN 65)	2409237013		1	100	pc.
88,9 (DN 80)	2409237014		1	65	pc.
114,3 (DN 100)	2409237015		1	40	pc.
139,7 (DN 125)	2409237016		1	33	pc.
168,3 (DN 150)	2409237018		1	25	pc.
219,1 (DN 200)	2409237019		1	15	pc.
273,0 (DN 250)	2409237020		1	12	pc.
323,9 (DN 300)	2409237021		1	8	pc.

 coil
  bar
  pipes in tube
  bag
  carton box
  pallet
  new
  available soon

* on request (delivery time up to 4 weeks) | ** availability by individual arrangements | *** till stock ends

NBR "C" type gasket
(for Z05, Z07, 7707, 7705 couplings)

GROUP: S

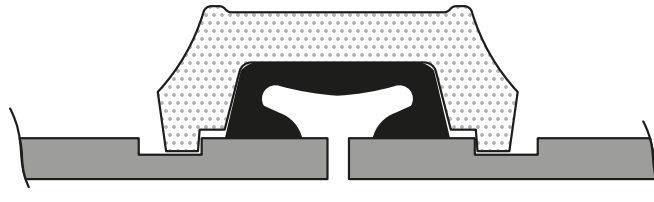

Size	Code	*			UM
33,7 (DN 25)	2409237022		1	300	pc.
42,4 (DN 32)	2409237023		1	210	pc.
48,3 (DN 40)	2409237024		1	170	pc.
60,3 (DN 50)	2409237025		1	120	pc.
76,1 (DN 65)	2409237026		1	100	pc.
88,9 (DN 80)	2409237027		1	65	pc.
114,3 (DN 100)	2409237028		1	40	pc.
139,7 (DN 125)	2409237029		1	33	pc.
168,3 (DN 150)	2409237031		1	25	pc.
219,1 (DN 200)	2409237032		1	15	pc.
273,0 (DN 250)	2409237033		1	12	pc.
323,9 (DN 300)	2409237034		1	8	pc.

EPDM gasket
(for Z05, Z07, 7707, 7705 couplings)

GROUP: S

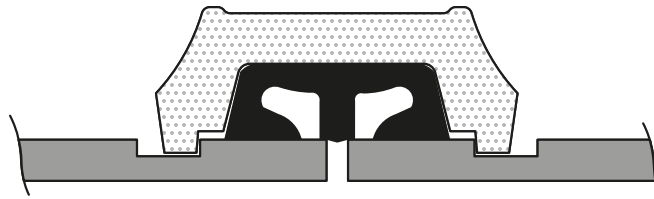

Size	Code	*			UM
42,4 (DN 32)	2409237035		1	210	pc.
48,3 (DN 40)	2409237036		1	170	pc.
60,3 (DN 50)	2409237037		1	115	pc.
76,1 (DN 65)	2409237038		1	90	pc.
88,9 (DN 80)	2409237039		1	60	pc.
114,3 (DN 100)	2409237040		1	35	pc.
139,7 (DN 125)	2409237041		1	30	pc.
168,3 (DN 150)	2409237043		1	22	pc.
219,1 (DN 200)	2409237044		1	12	pc.

coil
 bar
 pipes in tube
 bag
 carton box
 pallet
 new
 available soon

* on request (delivery time up to 4 weeks) | ** availability by individual arrangements | *** till stock ends

Lubricant

G223
GROUP: S



Capacity [g]	Code	*			UM
450	2400183000		1	24	pc.
900	2400183001		1	9	pc.

Tape measure Groove

GR600
GROUP: S



Size	Code	*			UM
3/4-24"	2400183003		-	1	pc.

EHC type lubricant

GROUP: S



Capacity [g]	Code	*			UM
270	2400183004		1	-	pc.

Note:
Use with H305 and H307 couplings intended for connecting with HDPE pipes.

coil
 bar
 pipes in tube
 bag
 carton box
 pallet
 new
 available soon

* on request (delivery time up to 4 weeks) | ** availability by individual arrangements | *** till stock ends

NOTES

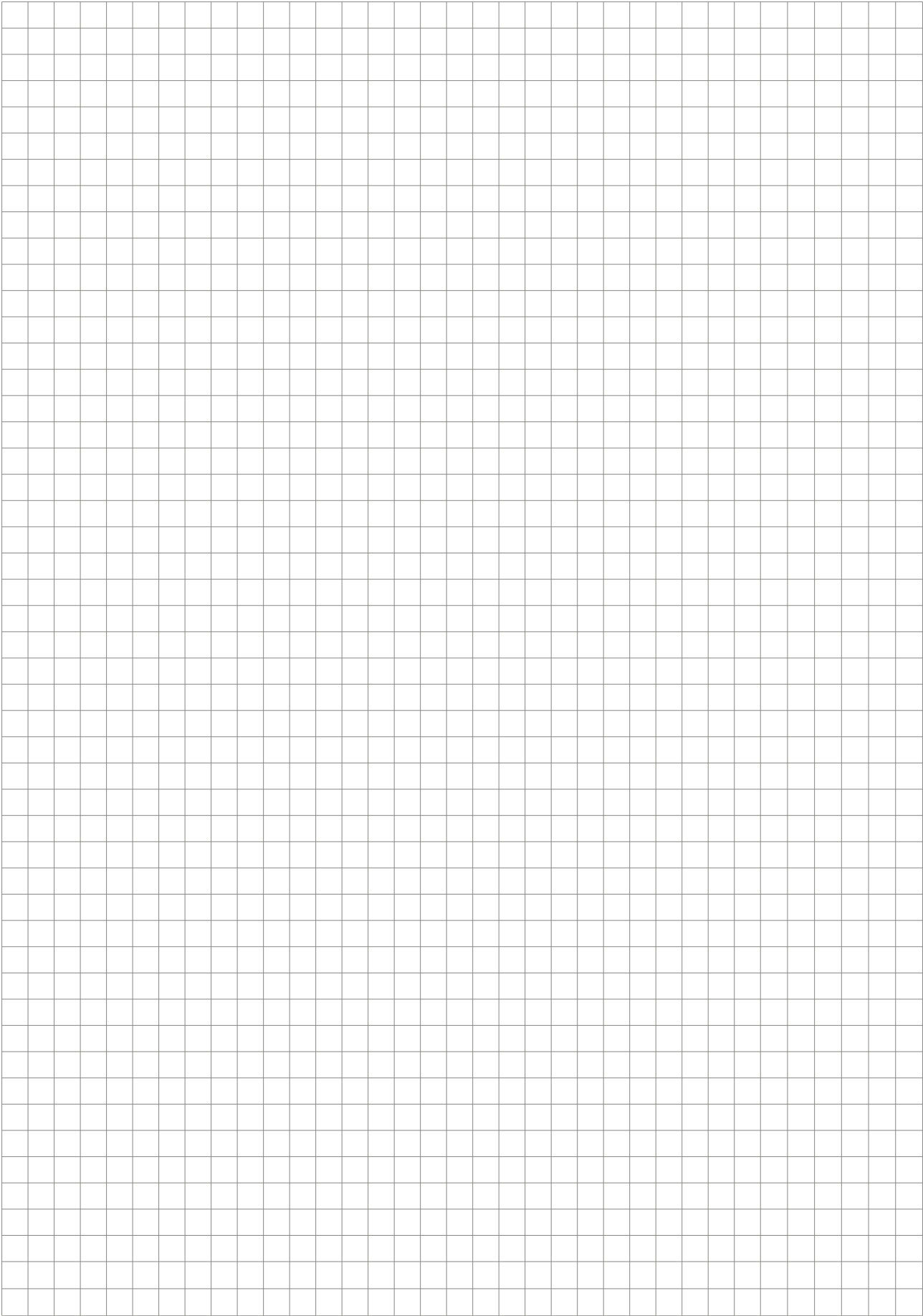

NOTES





Install your **future**

THE PRODUCTS WITH THE LABEL KAN-therm ARE DISTRIBUTED TO 68 COUNTRIES IN THE WORLD.

The distribution network covers Europe, a large part of Asia and also reaches Africa and America.



HEADQUARTERS

KAN Group

Zdrojowa St. 51, 16-001 Kleosin, Poland.











tel. +48 85 74 99 200

e-mail: kan@kan-therm.com

www.kan-therm.com

Multisystem **KAN-therm**

Complete multipurpose installation system consisting of state of the art, mutually complementary technical solutions for pipe water distribution installations, heating installations, as well as technological and fire extinguishing installations.

ultraLINE	
Push	
ultraPRESS	
PP	
Steel	
Inox	
Groove	
Copper, Copper Gas	
Sprinkler	
Surface heating and cooling, automation	
Football Stadium installations	
Cabinets and manifolds	